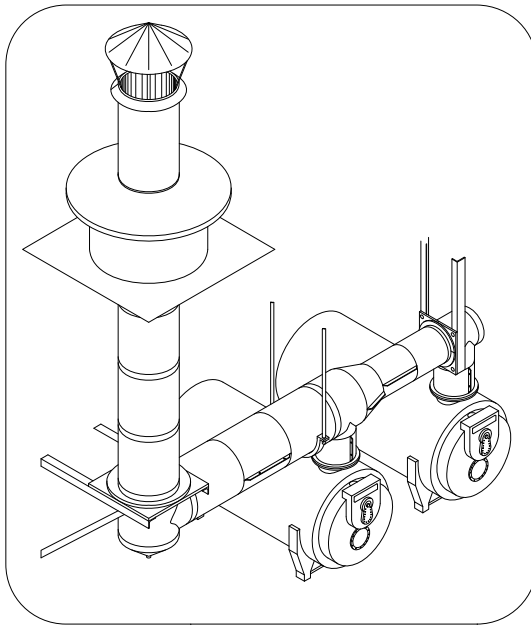


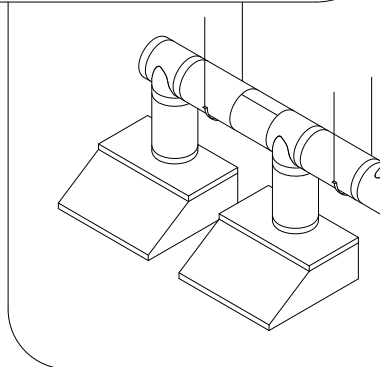
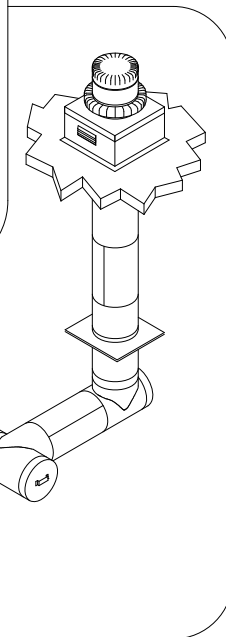
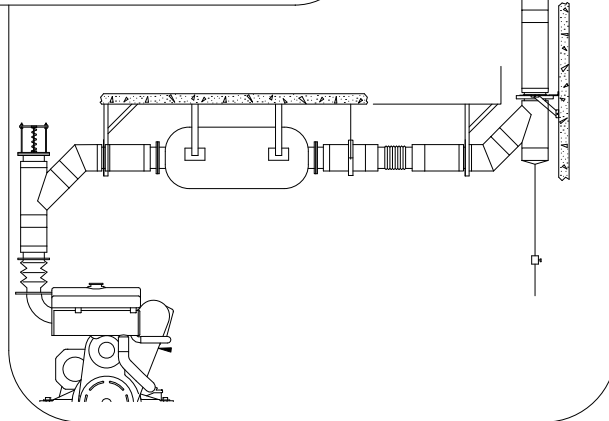
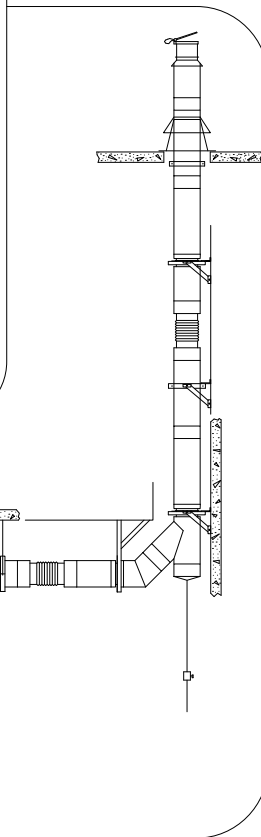


# INSTALLATION INSTRUCTIONS & MAINTENANCE GUIDE

## MODEL N, VSI, IVSI & ZC SINGLE WALL, DOUBLE WALL AIR & FIBER INSULATED POSITIVE PRESSURE PIPING SYSTEMS



- **BOILER STACK**
- **ENGINE EXHAUST**
- **GREASE DUCT**



A MAJOR CAUSE OF CHIMNEY RELATED FIRES IS FAILURE TO MAINTAIN REQUIRED CLEARANCES (AIR SPACES) TO COMBUSTIBLE MATERIALS. IT IS OF UTMOST IMPORTANCE THAT THIS CHIMNEY BE INSTALLED IN ACCORDANCE WITH THESE INSTRUCTIONS.

## Table of Contents

### A - General Information

Safety Precautions	3
Features	3
Underwriters Laboratories Listings	3
Applications	4
Use of Individual Parts	4
Surroundings / Enclosure	4
Multi-Engine Exhausts	4
Part Numbers	4
Clearances	5
Outer Pipe Surface Temperature	5
Pipe Joint Assembly	6
Sealant Usage	7
Pipe Weight	7
Support Methods	7
Vertical Support and Guide Spacing (Corrosion Protection: Exterior Pipe & Supports)	8
Thermal Expansion	9
Chimney Guying & Spacing	9
Seismic Requirements	10

### B - Fittings

45° Lateral Tee (P-JL)	11
90° Tee (P-MT)	11
Drain Tee Cap (P-TC)	11
Thermal Expansion Lengths	11
90° Wye (P-JY)	12
Stepped Increaser (P-OS)	12
Tapered Increaser (P-OT)	12
Elbows	12
Use of Elbows, Offsets w/ Manifolds	13

### C – Adjustable & Thermal Expansion

#### Fittings

Bellows Expansion Joint (P-BJ)	15
Adjustable Expansion Length (P-AG)	16
Non-Exp Variable Length (P-VL)	18
Short & Odd Lengths	18

### D – Structural Support & Guiding

Plate Support Assembly (P-PA)	19
Clamp Flange (P-CF)	19
High Strength Plate Support	20
Wall Support Assembly (P-WA)	20
Wall Guide Assembly (P-WG)	20
Floor Guide (P-FG)	22
Full Angle Ring (P-FR)	22

### E – Roof & Wall Penetrations

Roof Support Assembly (P-MRS)	23
Ventilated Roof Thimble (P-MVT)	23
Flashings & Storm Collar	26

### F – Terminations, Drains, Pressure Relief

Exit Cone (P-EC)	27
Closure Ring (P-CR)	27
Stack Cap (P-SK)	27
Drain Section (P-DS)	27
Termination Height	28
Flange Adapter (P-FD)	28
Boiler Kit Adapter (P-BK)	29
Seal Ring (P-SR)	29
Excessive Pressure Relief Valve (P-ER)	30

### G – Grease Duct

Listings	31
Surrounds	32
Clearances	32
Slope	32
Joint Assembly	33
Sealant	33
Maintenance & Safety	34
Automatic Cleaning	34
Fire Suppression	34
Hood Transition	35
Cleanout Tee Cap (P-TCN)	35
Fan Adapter (P-FA)	35
Fan Adapter Termination (FAT)	35
Roof Support Section (RSS)	35
Through Penetration Firestop (TPF)	37
No-Tool Access Cap (P-NTAC)	38
Field Installed Access Cap	39
Connecting to Rectangular Ducts	39
Inline Access Door	40
Sample Drawings	41

### H – Type B Gas Vent

Installation Instruction Supplement for Type B Gas Vent	43
--	----

# Installation Instructions

## Section A

## GENERAL INFORMATION

### SAFETY PRECAUTIONS

#### ⚠ WARNING

Failure to follow these Installation Instructions could cause FIRE, CARBON MONOXIDE POISONING, OR DEATH. If you are unsure of Installation requirements, call the Phone Number listed on the front of these instructions.

Caution-Risk of injury. Sheet metal parts may be sharp. Always wear gloves and appropriate eye, foot, and other protection when handling these products.

Follow these instructions carefully. Failure to follow these instructions could result in an unsafe installation. If you are unsure of any instructions contact the factory at the number indicated on the last page of these instructions.

A major cause of chimney/duct related fires is failure to maintain required clearances (airspace) to combustible materials. It is of utmost importance that this product be installed only in accordance with these instructions.

### FEATURES

Model N, VSI and IVSI products are cylindrical, prefabricated, modular venting systems incorporating flanged joints, designed for both quick assembly and pressure sealing capability. Model N is single wall vent. Model VSI is of double wall construction incorporating a 1" airspace between walls and Model IVSI incorporates 1" to 4" thick fiber insulation. Their circular cross section and high quality stainless steel inner wall construction provide for a system with high strength-to-weight ratio and low friction losses.

### UNDERWRITERS LABORATORIES LISTINGS

Ampco single wall Model N and double wall models VSI and IVSI venting systems are Listed by Underwriters Laboratories, Inc. (UL) under UL File MH6673 in the following product categories and in the diameters indicated:

Model N (Single wall pipe)	
Grease Duct for Restaurant Cooking Appliances	5" - 36"ID
Chimney Liner for Existing Chimneys (Canada) CAN/ULC S635	5" - 48"ID

Model VSI (Double wall, 1" air insulation)	
Building Heating Appliance Chimney	5"- 48" ID
1400° Fahrenheit Chimney	5"- 48"ID
Grease Duct for Restaurant Cooking Appliances	5" - 48"ID

Model IVSI (Double wall, 1, 2, 3 or 4" thick fiber insulation)	
Building Heating Appliance Chimney	5"- 48"ID
1400° Fahrenheit Chimney	5"-48" ID
Building Heating Appliance Chimney(Type HT)	5"- 24"ID
Low Temperature Venting System, Type L	5" - 24"ID
Grease Duct for Restaurant Cooking Appliances	5" - 48"ID

For Zero clearance grease duct applications (model IVSI-Z3 & IVSI-Z4) see Section G, "Grease Ducts".

### APPLICATIONS

**Building Heating Appliance Chimney Listing** - Under this category, Model VSI and IVSI have been determined suitable for venting flue gases at a temperature not exceeding 1000°F, under continuous operating conditions, from gas, liquid and solid fuel fired appliances. Intermittent operation (less than one hour) at temperatures not exceeding 1400°F, and brief (maximum 10 minute) operation at temperatures not exceeding 1700°F, is also permitted under this application.

**Building Heating Appliance Chimney (Type HT) Listing** - Under this category, the 5" through 24" ID Model IVSI has qualified for UL's additional, optional "Type HT" rating (for Building Heating Appliance Chimneys) which indicates they have been evaluated and found suitable for exposure to 2100°F flue gases for a 10 minute duration. Many local, state and regional code authorities require a "Type HT" rating for chimneys for certain appliance venting applications; especially solid fuel.

Building Heating Appliance Chimneys are suitable for use with Building Heating Appliances and other Low Heat Appliances as described in the Chimney Selection Chart of National Fire Protection Association (NFPA) Standard No. 211.

**1400°F Chimney Listing** - Under this category, Model VSI and IVSI have been determined suitable for venting flue gases at a temperature not exceeding 1400°F, under continuous operating conditions and intermittent service (less than one hour) at temperatures not exceeding 1800°F. As such, Model VSI and IVSI are suitable for use with ovens and furnaces as described in the Chimney Selection Chart of NFPA No. 211, in addition to other Applications.

**Low Temperature Venting System, Type L (L-Vent) Listing** - Under this category, 5" through 24" ID Model IVSI has been determined suitable for use with gas and oil fueled appliances Listed as suitable for venting with Type L or Type B venting systems. This qualifies the system for handling continuous flue gas temperatures at a maximum of 480°F above ambient, and permits full enclosure in combustible chase construction, assuming the specified minimum airspace clearance-to-combustibles is maintained.

**Grease Duct for Commercial Cooking Appliances Listing** - Applications and instructions for this category are covered in Section "G" entitled "Grease Duct".

Based upon the above referenced UL Listings and supplemental, UL confirmed pressure testing, Model VSI and IVSI are also suitable for use as complete exhaust systems for diesel engine and gas turbines. When Model VSI/IVSI is used as an engine or turbine exhaust it is intended to be installed in accordance with NFPA 37 "Stationary Combustion Engines and Gas Turbines". This code states, "When such (flue gas) temperatures do not exceed 1000°F (538°C) except for infrequent, brief periods, the engines shall be classified as low heat appliances". For continuous operation over 1000°F and not exceeding 1400°F the exhaust system should be installed as a 1400°F Chimney.

Model IVSI may be used to meet various needs, such as:

- a) Reduce outer pipe surface temperature.
- b) Reduce building heat gain by retaining energy inside the duct.
- c) Increase the efficiency of energy recovery systems by reducing exhaust gas temperature losses.
- d) Increase chimney or exhaust system draft loss performance due to reduced exhaust gas temperature drop.
- e) Reduce building noise levels caused by high speed or pulsating exhaust induced noise. NOTE: Specific tests have not been conducted to measure acoustic performance.

Model VSI and IVSI exhaust systems are intended for use in connecting the heating appliance, engine, or turbine to the outdoors, while operating under positive forced draft, negative induced draft or neutral gravity flow internal pressure conditions. Model VSI and IVSI (all insulation thicknesses) may be intermixed in the same chimney system, assuming the proper associated airspace clearances-to-combustibles are maintained.

Complete system sizing and capacity information may be obtained from the "Chimney, Gas Vent, and Fireplace Systems" chapter of the ASHRAE Handbook, or by contacting Ampco Technical Support. In spite of these general sizing guidelines, it is most important that the heating appliance, engine or turbine manufacturer's installation instructions are followed. Not following the equipment manufacturer's instructions may result in inadequate chimney performance and/or a violation of the equipment manufacturer's installation requirements.

#### **ADDITIONAL APPLICATIONS**

Model N, VSI & IVSI are also suitable for negative, neutral or positive pressure pre-fabricated piping systems intended for use in a variety of applications including but not limited to the following: Fume Venting, Chimney Liner, Chutes, Particle Conveying, Dryer Vents and Ventilation Ducts.

SUITABLE FOR POSITIVE PRESSURE VENTING APPLICATIONS WITH MAXIMUM 60" WATER COLUMN INTERNAL STATIC PRESSURE AT 1000 DEGREES F.

#### **CREOSOTE AND SOOT – FORMATION AND NEED FOR REMOVAL**

When wood is burned slowly, it produces tar and other organic vapors, which combine with expelled moisture to form creosote. The creosote vapors condense in the relatively cool chimney flue of a slow-burning fire. As a result, creosote residue accumulates on the flue lining. When ignited this creosote makes an extremely hot fire.

The chimney should be inspected at least once every 2 months during the heating season to determine if a creosote or soot buildup has occurred; if creosote or soot has accumulated, it should be removed to reduce the risk of chimney fire.

Refer to Elbow & Offset section for additional limitations with regards to burning solid fuel.

#### **USE OF INDIVIDUAL PARTS**

These instructions comprise both general guidelines and special requirements for all parts in the product line. Before specifying a design or beginning an installation please carefully review these instructions.

#### **SURROUNDINGS / ENCLOSURE**

Ampco Model N, VSI and IVSI chimneys are primarily intended to be used in fire resistive, noncombustible surroundings or installed unenclosed. They are not intended for use in one or two family residences. (CAUTION — Do not enclose this chimney in a chase or passageway of ordinary wood or other combustible material.)

For Type L Vent installations, Model IVSI may be enclosed within a chase fabricated from combustible building materials. Check local codes to determine the required fire rating, if any, for such chase enclosures.

Where the chimney extends through any zone of a building (outside that in which the heating appliance connected to it is located), it shall be provided with an enclosure having a fire resistance rating equal to or greater than that of the floor, ceiling, wall or roof assemblies through which it passes.

Model VSI and IVSI Chimney may penetrate a combustible roof using either the Roof Support Assembly (P-MRS) or the Ventilated Roof Thimble (P-MVT). These are the only parts intended for use with combustible construction. All other parts, such as Plate and Wall Supports, and Floor and Wall Guides, are for attachment to non-combustible construction.

Where, according to local code, no chase enclosure is necessary, Model VSI and IVSI may be placed adjacent to walls of combustible construction at the minimum clearance specified on each pipe section and in the individual Listing; see CLEARANCES section and Tables A-1a through A-1d. Contact local building or fire officials about restrictions and installation inspection requirements in your area.

#### **MULTI-ENGINE EXHAUSTS**

A common exhaust system for multiple engine or turbine installations is generally not recommended. Check with your engine or turbine manufacturer prior to common exhaust system design. Exhaust gas from operating units tends to flow to non-operating units where condensation may form. Water in engine or turbines at start-up may cause damage. In general, a separate exhaust system should be provided for each engine or turbine.

#### **PART NUMBERS**

These instructions identify major Model N, VSI and IVSI parts by name or part number. Actual parts always carry a prefix to indicate internal diameter. IVSI also includes a suffix to indicate insulation thickness. For example: 24VSI-42 is a 24 inch diameter of model VSI, 42 inches in length; 24IVSI-42C2 is a 24 inch diameter section of Model IVSI, 42 inches long having 2 inches of fiber insulation between the walls.

## CLEARANCES

Venting Category	Maximum Continuous Flue Gas Temp.	Type Clearance
Type L Vent	480°F over ambient	Enclosed*
Building Heating Appliance Chimney (BHA)	1,000°F	Unenclosed*
B.H.A Chimney (Type HT)(IVSI 5"-24")	1,000°F	Unenclosed*
1,400°F Chimney	1,400°F	Unenclosed*
Grease Duct	500°F	Unenclosed*

\* = See Section Entitled "Surroundings/Enclosure"

Pipe I.D.	Type L Vent	Building Heating Appliance Chimney (1,000°F)	1,400°F Chimney	Grease Duct
5-16"	2"	0.5"	0.5"	A
18"	2"	1"	2"	A
20"	2"	1.5"	2"	A
22-24"	2"	2"	2"	A
26-32"	-	3"	3"	A
36"	-	4"	4"	A
42-48"	-	5"	5"	A

See Section "G", Grease Ducts
-------------------------------

A = See Section "G" Entitled "Grease Duct"

For non-combustible construction, maintain clearances as required for installation, access for inspection or per local code.

Pipe I.D.	Type L Vent	Building Heating Appliance Chimney (1,000°F)	1,400°F Chimney	Grease Duct
5-16"	-	6"	6"	A
18"	-	7"	8"	A
20"	-	7"	9"	A
22"	-	8"	10"	A
24"	-	8"	12"	A
26"	-	8"	13"	A
28"	-	9"	14"	A
30"	-	9"	16"	A
32"	-	10"	17"	A
34"	-	10"	19"	A
36"	-	10"	20"	A
42"	-	11"	20"	A
48"	-	12"	20"	A

### OUTER PIPE SURFACE TEMPERATURE

As an aid for estimating expected outer wall surface temperatures, fiber insulated Model IVSI has been tested in a vertical configuration using input energy levels consistent with "UL 103; Standard for Chimneys, Factory-Built, Residential Type and Building Heating Appliance". Testing with 1, 2 and 4 inch insulation thicknesses resulted in development of Chart A-1 and Table A-2, indicating the maximum expected outer surface temperatures. Compared to vertical configurations, horizontal configurations of Model IVSI will have lower surface temperatures due to a higher convective heat transfer coefficient. Thus, for horizontal configurations, Chart A-1 and Table A-2 are acceptable to use as they will give conservative answers. The Tables in A-2 give the same results as Chart A-1 for the indicated outer pipe surface temperature, flue gas temperature and pipe size at an ambient temperature of 70°F.

The chart can also be used for other operating conditions. For example, at an actual flue gas operating temperature of 400°F (corresponding to a flue gas temperature rise of 330°F at an ambient temperature of 70°F), all diameters of Model IVSI would require 1 inch of insulation to maintain the outer surface temperature below 140°F.

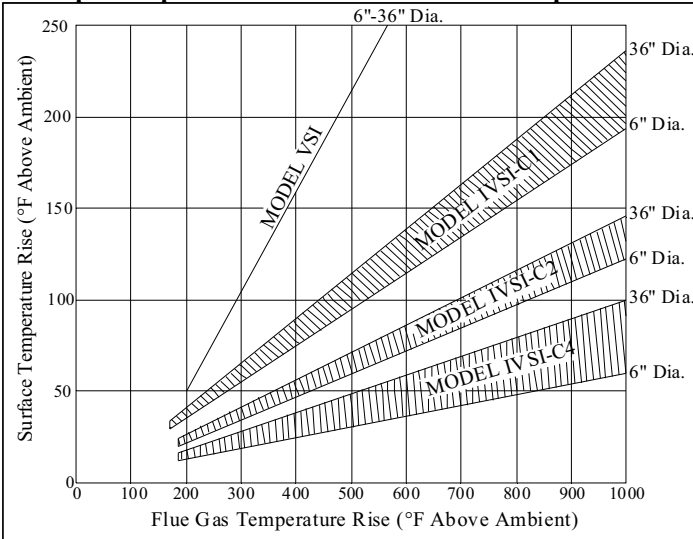
Note: These tests were all conducted in accordance with UL-103 in a vertical configuration with 1000°F flue gases and air surrounding the pipe. Appreciable higher outer wall surface temperatures would have been reached if insulation had been placed around the outer wall of the pipe.

**Do not wrap or place insulation** around these systems in an effort to reduce clearances to combustibles, create some type of fire protective enclosure or for any purpose – unless Ampco Corp and the Authority Having Jurisdiction have reviewed and approved such action.

Pipe I.D.	Type L Vent	Building Heating Appliance Chimney (1,000°F)	1,400°F Chimney	Grease Duct
5-6"	3"	1"	1"	A
8"	3"	1"	2"	A
10-16"	3"	2"	2"	A
18-24"	3"	3"	3"	A
26-32"	-	4"	4"	A
36"	-	5"	5"	A
42-48"	-	6"	6"	A

A = See Section "G" Entitled "Grease Duct"

**Chart A-1: Model VSI and IVSI Estimated Maximum Outer Pipe Temperature Rise above Ambient Temperature**



**Table A-2a: Required Insulation thickness for 120°F Surface Temp**

Flue Temp	IVSI Duct Diameter			
	6"	12"	24"	36"
1000°F	-	-	-	-
900°F	-	-	-	-
800°F	4	4	-	-
700°F	4	4	-	-
600°F	4	4	4	-
500°F	2	4	4	4
400°F	1	2	2	2
300°F	1	1	1	1

**Table A-2b: Required Insulation thickness for 140°F Surface Temp**

Flue Temp	IVSI Duct Diameter			
	6"	12"	24"	36"
1000°F	4	4	-	-
900°F	4	4	-	-
800°F	4	4	4	-
700°F	4	4	4	4
600°F	2	2	4	4
500°F	1	2	2	2
400°F	1	1	1	1
300°F	1	1	1	1

**Table A-2c: Required Insulation thickness for 160°F Surface Temp**

Flue Temp	IVSI Duct Diameter			
	6"	12"	24"	36"
1000°F	4	4	4	-
900°F	4	4	4	4
800°F	4	4	4	4
700°F	2	2	2	4
600°F	2	2	2	2
500°F	1	1	1	2
400°F	1	1	1	1
300°F	1	1	1	1

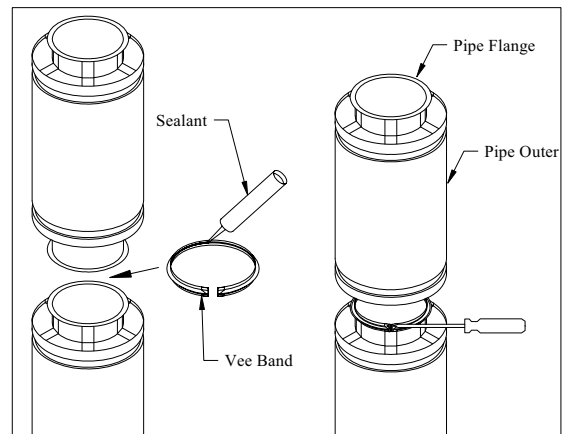
**PIPE JOINT ASSEMBLY**

All flange-to-flange inner pipe joints are identical (except for Adjustable Lengths, Variable Lengths and Lined Bellows Joints), thus eliminating special orientation for correct use. Assembly is accomplished as follows:

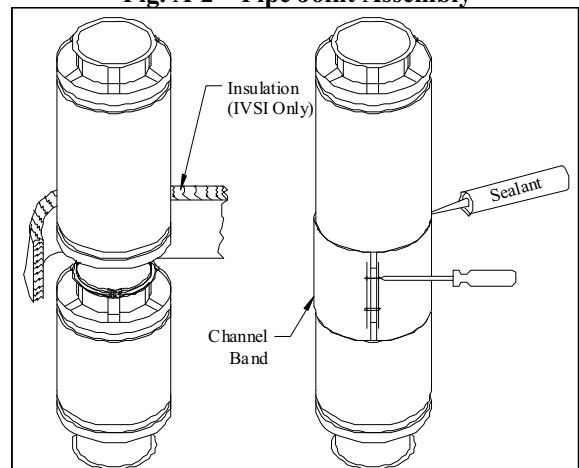
1. Parallel flanges are brought together (See Fig A-1).
2. Sealant is applied to the groove of the inner "V" Band. Refer to SEALANT USAGE section for proper sealant selection.
3. The inner "V" band is then tightly clamped around the flanges using end clamp hardware. NOTE: Light tapping with a wooden or similar mallet all around the band while tightening the clamp helps to align and pull the flanges together (See Fig A-1).
4. (For Model IVSI only) insert strip of insulation (supplied) in area of V-band, around entire circumference of assembly. Position insulation to insure no void spaces remain (See Fig A-2).
5. The outer channel band is then installed by inserting the edges of the band into the outer pipe grooves and drawing it closed with the screws and nuts. For vertical exterior joints apply sealant to the joint between the Channel Band and the outer pipe (See Figs. A-2 & A-3). \*For horizontal/sloping exterior joints, it is recommended to apply sealant (P-600) to both sides of the Channel Band (top side is sufficient (9 o'clock to 3 o'clock position)) with nut/bolt connection pointing down

**Caution-Risk of injury. Sheet metal parts may be sharp. Always wear gloves and appropriate eye, foot, and other protection when handling these products.**

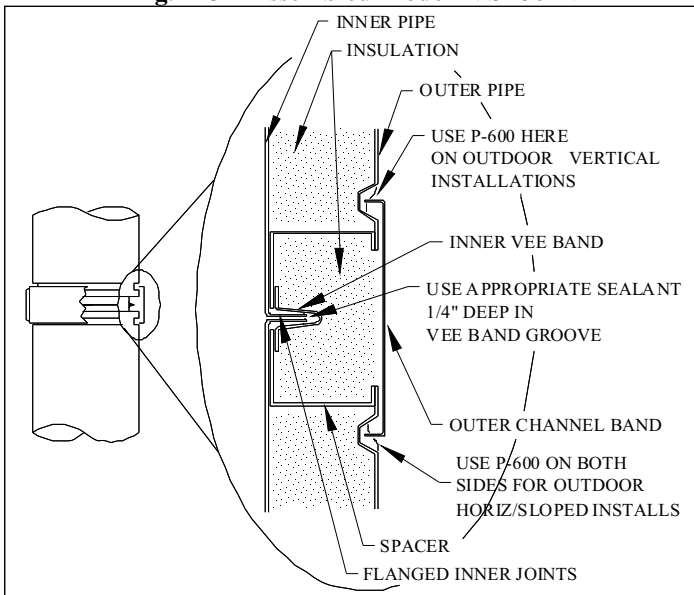
**Fig. A-1 – Pipe Joint Assembly**



**Fig. A-2 – Pipe Joint Assembly**



**Fig. A-3 – Assembled Model IVSI Joint**



**CAUTIONS**

- A. THE OUTER CHANNEL BANDS ARE DESIGNED TO SLIDE IN THEIR MATING GROOVES. DO NOT ATTACH BY SCREWS INTO THE OUTER CASING.
- B. DO NOT ALLOW SCREWS TO PENETRATE THE INNER PIPE. THIS CAN CAUSE CORROSION, GAS LEAKAGE OR EXPANSION FAILURE.
- C. NEVER USE SCREWS THROUGH THE OUTER JACKET OF AN ADJUSTABLE LENGTH OR EXPANSION JOINT.

**SEALANT USAGE**

- 1. Part No. P-600: a silicone sealant for flue gas temperature up to 600°F. Also used for weathering/sealing on outdoor seams & Channel Bands where necessary.
- 2. Part No. P-2000: a high temperature pre-mixed sealant for flue gas temperature up to 2000°F. P2000 IS WATER SOLUBLE AND SHOULD NOT BE USED WHERE EXPOSED TO WEATHER.

<b>Sealant Coverage (Expected Number of Joints Sealed per Tube)</b>	
Inner Dia.	# of Joints
5-6"	10
8-10"	9
12"	8
14-16"	7
18-20"	6
22-24"	5
26-28"	4
30-32"	3
36"	2
42-48"	1

**PIPE WEIGHT**

The approximate weight of the pipe in lbs. per foot is equal to its Multiplier multiplied by its inside diameter (in inches). See chart below

<b>Weight of Pipe</b>	
Model	Multiplier
N	0.5
VSI	0.9
IVSI-C1	1.1
IVSI-C2	1.3
IVSI-C4	1.7
IVSI-Z3	1.7
IVSI-Z4	2.0

Example:  
36"IVSI-C1 weighs  
approximately 36 x 1.1 =  
39.6 Lbs/Ft.

**SUPPORT METHODS**

Vertical Installations require one of following methods of support. Refer to the corresponding section for proper installation instructions.

- 1. Pier or Appliance outlet (See Section B for details)
- 2. Base supported tee (See Section B)
- 3. Plate Support Assembly (P-PA) (See Section D for details)
- 4. Roof Support Assembly (P-MRS). (See Section F for details)
- 5. Wall Support Assembly (P-WA) (See Section E for details)
- 6. Fan Adapter Termination (FAT) (See Section G for details)
- 7. Roof Support Section (RSS) (See Section G for details)

Table A-3, (Support Methods & Height Limits), shows the maximum height limits for each support method.

Full Rings (P-FR) are used in vertical installations as wall guides to maintain proper alignment of the system and are for lateral support for wind loads. Proper spacing of full ring guides and supports must be maintained. Requirements can be found in Table A-4, (Vertical Support & Guide Spacing), under the columns designated "S-V".

The vertical freestanding height above the roof or top guide is limited due to wind considerations. The limitations for "Free Standing Height", can be found in Table A-4 under the columns designated "F". The table includes height limits for all vertical support methods based on model designation and diameter.

Horizontal installations or horizontal portions of vertical installations are supported primarily by use of Half Rings (P-HR) or Support Straps (P-SS) that are installed using minimum 1/2" threaded rod or structural steel provided by other. See Table A-5 for maximum spacing between horizontal supports. Plate Supports (P-PA) are also used to support and stabilize the system at changes in direction. For further details on the use of the Plate Supports, see section D.

**Table A-3 Support Methods and Height Limits**

	Parts Used	IVSI-C1	IVSI-C2	IVSI-C4 & Z3	IVSI-Z4	VSI	N
Pier or Appliance Outlet Sizes 5 thru 8"	P-CF & P-BK	82'	56'	30'	26'	100'	150'
Base Supported Tee	P-MT & P-BK	29'	20'	16'	14'	35'	50'
Plate Support Assembly							
Sizes 5" – 20"	P-PA	162'	108'	55'	47'	200'	300'
Sizes 22" – 48"	P-PA	82'	56'	30'	26'	105'	150'
Plate Support Assembly with High Strength Base (See Fig. D-3)							
Sizes 5" – 20"	P-PA	243'	162'	82'	70'	300'	NA
Sizes 22" – 48"	P-PA	123'	84'	45'	38'	150'	NA
Roof Support Assembly	P-MRS	8'	7'-10"	7'-7"	6'-6"	8'	NA
Wall Support Assembly	P-WA	30'	20'	15'	13'	30'	NA
Fan Adapter Termination	P-FAT	Models Z3 & Z4 Only – See Table G-2					
Roof Support Section	P-RSS	Models Z3 & Z4 Only – See Table G-2					
Full Angle Ring	P-FR	See Table A-4: Dimension S-V (See Fig. A-6, A-7, A-8, D-6 for examples)					
Guy Section	P-GS						
Wall Guide	P-WG						
Floor Guide	P-FG						
Free Standing Height above Full Angle Ring, Guy Section, Wall Guide and Floor Guide.		See Table A-4: Dimension F (See Fig. A-6, A-7, A-8, D-6 for examples)					
Support Strap		For horizontal use only (See Table A-5, S-H)					

**Notes:**

1. Pier or appliance must be able to support pipe weight (and guy loads, if any) regardless of maximum height.
2. P-MT and P-JL with integral internal stiffener posts are available for increasing base supported tee heights. Consult factory for details. In general, base supported tees are the least desirable alternative.

**Table A-4 Vertical Support and Guide Spacing**

Dia. (In.)	VSI & IVSI-C1		IVSI-C2		IVSI-C4, Z3 & Z4		Model N	
	S-V	F	S-V	F	S-V	F	S-V	F
5	17'0"	8'6"	15'4"	7'8"	12'8"	6'4"	23'10"	NA
6	17'6"	8'9"	15'10"	7'11"	13'4"	6'8"	23'4"	NA
8	18'6"	9'3"	16'10"	8'5"	14'6"	7'3"	23'2"	NA
10	19'4"	9'8"	17'10"	8'11"	15'6"	7'9"	23'2"	NA
12	20'4"	10'2"	18'10"	9'5"	16'8"	8'4"	23'9"	NA
14	21'2"	10'7"	19'10"	9'11"	17'10"	8'11"	24'2"	NA
16	22'2"	11'1"	21'0"	10'6"	19'0"	9'6"	24'2"	NA
18	23'2"	11'7"	22'	11'	20'2"	10'1"	25'9"	NA
20	24'	12'	23'	11'6"	21'4"	10'8"	26'5"	NA
22	24'10"	12'4"	23'8"	11'10"	22'	11'	27'1"	NA
24	25'6"	12'9"	24'6"	12'3"	23'	11'6"	27'1"	NA
26	26'4"	13'1"	25'	12'6"	23'8"	11'10"	28'4"	NA
28	27'	13'6"	26'2"	13'1"	24'8"	12'4"	28'11"	NA
30	27'-10"	13'10"	26'10"	13'5"	25'4"	12'8"	29'9"	NA
32	28'6"	14'3"	27'8"	13'10"	26'4"	13'2"	30'3"	NA
36	30'	15'	29'2"	14'7"	27'10"	13'11"	31'8"	NA
42	26'6"	13'3"	25'10"	12'11"	24'10"	12'5"	27'9"	NA
48	23'	11'6"	22'8"	11'4"	21'10"	10'11"	23'11"	NA

S-V = Maximum spacing between two guides or a support and a guide in a vertical position.  
 F = Maximum height above a guide or support for free standing system above a roof or parapet wall.

**Table A-5: S-H Horizontal Support Spacing Half Rings (P-HR), Full Rings (P-FR) & Support Straps (P-SS)**

Dia.	VSI & IVSI-C1	IVSI-C2	IVSI-C4, Z3 & Z4	Model N
5"-12"	16'	14'	12'	20'
14"-24"	14'	12'	10'	17'
26"-48"	11'	9'	7'	11'

**EXTERIOR CORROSION PROTECTION:**  
 IT IS RECOMMENDED TO APPLY AN EXTERIOR GRADE HIGH HEAT PAINT TO ANY PLATE SUPPORTS, FULL/HALF ANGLE RINGS, WALL SUPPORTS/GUIDES, ALUMINIZED OUTER WALLS & ROOF/WALL FLASHING COMPONENTS, EXPOSED OUTDOORS TO ENSURE MAXIMUM CORROSION PROTECTION AGAINST THE ELEMENTS. (Ex. Rustoleum V2100 series High Heat Industrial Aerosol)



## THERMAL EXPANSION

Good installation practice requires that any length of exhaust system between two fixed points subject to more than 1/4 inch expansion must have an Adjustable Length (P-AG) or Bellows Joint (P-BJ) to compensate for expansion. VSI/IVSI will expand approximately 1 inch for every 100°F temperature rise per 100 feet of pipe.

For Grease Duct applications any length over 12 feet installed between two fixed points i.e.: Hood Outlet and Elbow, Plate and Wall Support, etc., must be provided with an Adjustable Length (P-AG) to compensate for expansion and contraction.

It is essential that these parts be properly installed and provided with adequate guidance to prevent binding or excessive bending forces. (See detailed installation information contained in Section C, Thermal Expansion.)

The exhaust system designer must be aware that the inner joints have negligible flexing capability, and in addition, Tees and Elbows are not designed to withstand excessive bending forces. Because the amount of outer casing axial movement is less than the inner casing movement, but still significant, the outer jackets of piping and Adjustable Lengths must also slide to avoid excessive forces on Tees, Elbows or Fixed Joints. To accommodate outer casing movements, external guides along walls, at floors, or in lateral breechings, must allow for movement of the pipe. Further; Full/Half Rings, Wall Guides or Floor Guides must be so located that Outer Channel Band movements will be away from the ring.

## CHIMNEY GUYING AND BRACING

Model N, VSI, IVSI, Z3 & Z4 Grease Duct has thin pipe walls relative to its diameter ( $t/D < 0.006$  for all sizes) and has the characteristics of a continuous pipe of 300 Series Stainless Steel. Therefore it will expand and contract along its entire length with changes in temperature. Thus, unless properly supported and guided, structural damage to the exhaust system will occur. For these reasons, conventional methods of attaching guides and braces to the outer pipe cannot be used. Correctly installed Angle Rings (P-FR and P-HR), Wall Guides (P-WG), Floor Guides (P-FG), Guy Sections (P-GS), Plate Support Assemblies (P-PA) and Wall Support Assemblies (P-WA) will serve to keep the chimney aligned and supported, provide for adequate wind load resistance and allow for axial thermal expansion and contraction.

Stabilization of the part of the chimney which extends above the roof or a parapet wall requires special consideration. For low, freestanding installations (up to Dimension F in Table A-4) the chimney needs no special guying or bracing. However, to protect the roof flashings from loads caused by wind against the exposed chimney, the installation must be stabilized with a Full Angle Ring (P-FR) as illustrated in Fig. A-6.

In addition to the requirement for alignment and stabilization of the chimney, the need often exists for guying or otherwise bracing taller chimneys to resist upsetting forces. The Model VSI or IVSI part that can be used for this purpose is called a Guy Section (P-GS). It is composed of two pieces of standard 18 inch long pipe welded together and rigidly captured between two heavy duty steel flanges that are welded together about their entire perimeter (see A-4 for details). With holes every 30°, the heavy duty attachment allows great flexibility of multiple cable guys (a minimum of three). In all but the simplest

installation, contact the factory for complete guy tension and preload calculations.

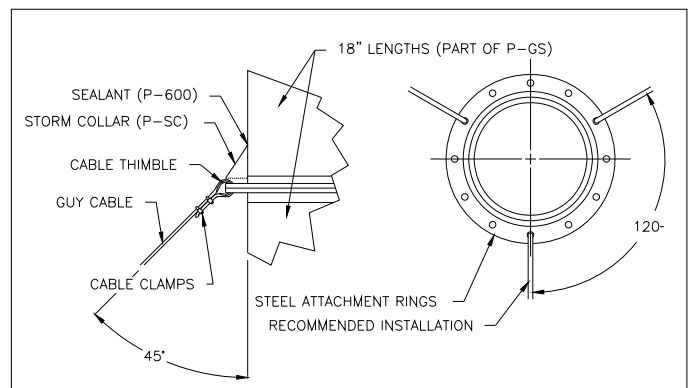
The purpose of guying or bracing is to prevent wind effects from developing excessive bending forces or horizontal displacements in exposed chimneys. This means that cables which are attached to the guy section must be slightly slack or loose, allowing for thermal expansion to occur without damaging fasteners or attachments. Some stack configurations require spring loaded Guy Tensioners (P-GT) to preload the guy cables for a satisfactory installation (See Fig. A-9). These displacement limiting tension devices must be incorporated in cable guys if expected thermal expansion exceeds allowable slack in the cables.

For stack heights above the roof requiring guy wires or rigid bracing to minimize thermal expansion effects, a Plate Support Assembly (P-PA) or Wall Support Assembly (P-WA) must be installed at or near the roof line. If necessary, Guy Tensioners should be used.

The height limit of a Model VSI/IVSI stack above the roof can vary depending on the Stack Support involved (see Table A-3) and whether the stack is welded, braced or guyed. Using the Roof Support (P-MRS), the maximum height allowed is dependent on size as indicated in Fig. A-6 and its accompanying Table A-4

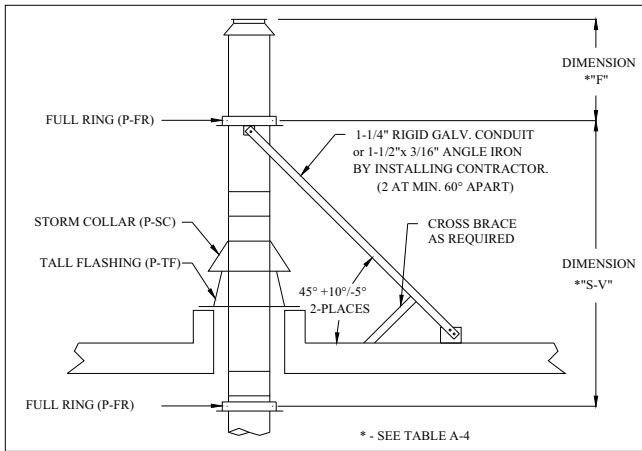
For stacks greater than those specified for single Guy Section configurations (See Fig. A-6) such as two level guying or those that will be located in severe weather locations, a welded Model IVSI assembly is recommended. The availability of multi-level guying (as shown in Fig. A-7) depends on wind load, height, pipe diameter and material thickness. Not all multilevel guying height and diameter combinations are possible. Contact the factory for a detailed design of welded multi-guyed Model VSI/IVSI stacks.

**Fig A-4. Guy Section details and cable attachments**

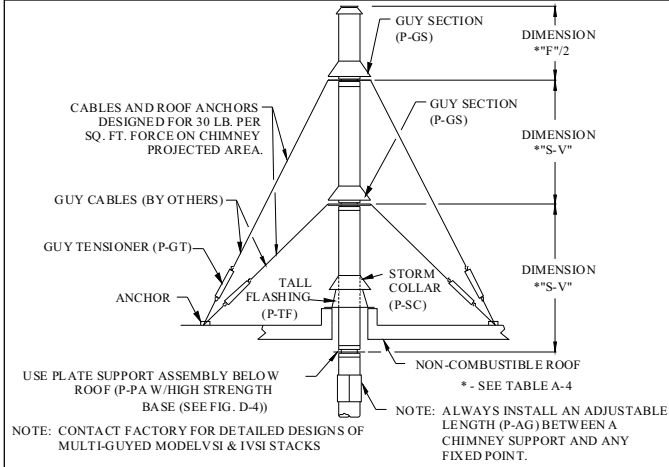


Guy wires should be attached to flanges of the Guy Section at appropriate locations. If the exposed stack is to expand by sliding vertically within a fixed structural framework of either wall guides or floor guides, the rings for those parts should be located just below the upper channel band of the involved pipe section. Wire cable, pipe or angle-iron are all suitable materials for guying or bracing. Galvanized or stainless steel is recommended for durability and ease of maintenance.

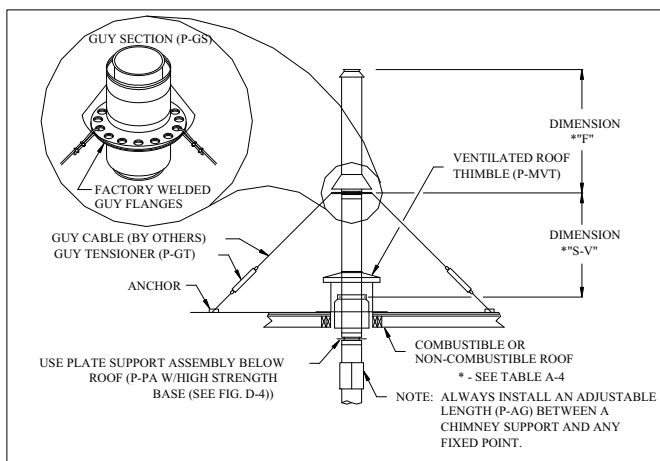
**Fig. A-6. Height Limits for single set of Rigid Braces**



**Fig. A-7. Guying Requirements Example for Maximum Height above roof for multiple sections of Model VSI/IVSI**



**Fig. A-8. Guying Requirements for Chimneys Supported at Roof**



**CHIMNEY GUYING AND BRACING (cont'd)**

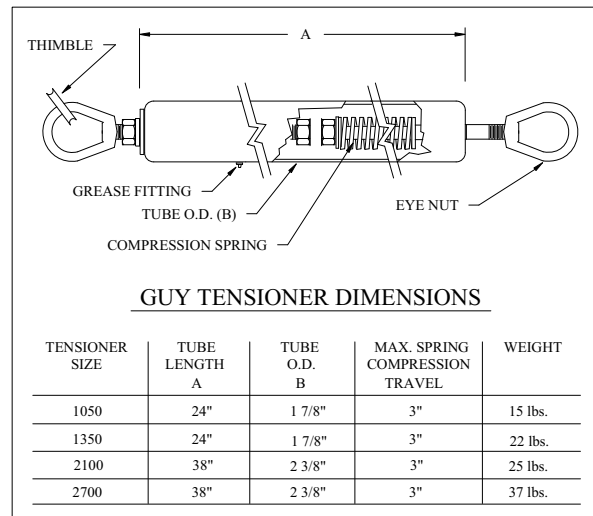
Cable guying is often not as desirable as pipe or angle iron bracing. Cable tensioning requires periodic adjustment and a minimum of three points are required at each guying level. Where guying is used, usual thermal expansion and contraction must be carefully considered to avert excessive loads on points of attachment and supports.

When rigid braces are used in conjunction with a Full Angle Ring, often only two braces are required, with a minimum plan view angle between them of not less than 60°. See fig. A-6 for an example using rigid braces with a Full Angle Ring.

Another structurally equivalent alternative to guy wires and one which puts less load on the stack and its support structure is to use a Full Ring (P-FR) firmly attached to three rigid legs in a tripod arrangement in lieu of a Guy Section and guy wires (see Fig. A-8). Many other structurally equivalent solutions are possible.

NOTE: All guying materials, except Guy Sections and Tensioners, are by others and normally can be readily and economically obtained locally.

**Fig. A-9. Guy Tensioner**



**SEISMIC REQUIREMENTS**

In certain areas of the country, local codes contain requirements to address seismic risks. Seismic requirements for chimneys and grease ducts usually include specifications for additional "sway bars" / bracing, or similar devices in order to help stabilize the system in the event of an earthquake.

Specific guidelines (including spacing, location, size and method of attachment of bracing / sway bars or other devices) for addressing seismic requirements vary depending upon the adopted code, seismic zone, duct size, location in building, etc. and are not within the scope of these installation instructions.

Consult with a design professional in order to determine compliance options for these potentially complex requirements when this product is to be installed in a building where these additional requirements apply.

The support methods described in these instructions have been proven adequate (via UL certification) for locations where there are no additional seismic zone requirements. In order to address additional seismic requirements they may be further supplemented with a variety of generic sway bars or braces that attach to or around the outer wall of the grease duct system. Full Angle Rings (P-FR), Half Angle Rings (P-HR) and Support Straps (P-SS) may be included as components of such supplemental bracing.

**45° LATERAL TEE (P-JL)**

For systems that require a 45° entry to the vertical chimney, the 45° Lateral Tee may be supported or suspended similar to a 90° Tee, (see next item). Use of this part necessitates an additional 45° Elbow if there is a horizontal breeching (see Fig. B-1b). When base supported, the 45° Tee will carry a maximum of 30 feet of chimney height (see support methods in Section A), and may be installed with a cap or cleanout exactly the same as the 90° Tee. See Fig. B-5 for an example of the use of 45° Lateral Tees in a manifold breeching. This system has lower flow losses than using 90° Tees and thus, for any given set of appliances, a smaller diameter manifold can be used.

**90° TEE (P-MT)**

The 90° Tee will support up to 30 feet of vertical chimney height when it is supported from below. This tee fitting is used to join horizontal connectors into a vertical chimney as well as a drain or inspection fitting. For the latter purpose, the Drain Tee Cap (TC) is installed at the base of the tee, and piped to a suitable drain. NOTE: The 90° Tee should not be used on engine or turbine exhausts except when used as an inspection access where there is no change in flow direction.

**TEE PRECAUTIONS**

1. Use an expansion joint in all horizontal breechings or laterals.
2. Provide access for easy removal of Tee Cap.
3. Use two axis support as in Fig. B-2a and B-2b to protect Tees or Elbows, if over 1/4 inch of expansion is expected in the lateral or breeching.
4. Never support any Model VSI/IVSI pipe from the outer casing.
5. Always install system so that sliding of expansion joints takes place, rather than bending at fittings.
6. Never allow more than 35 feet of chimney / duct above a base supported tee without resupporting.

**DRAIN TEE CAP (P-TC)**

The Drain Tee Cap is used as an end cap in horizontal runs, as an inspection fitting cover, and as a drain for vertical stacks. When not used as a drain the nipple shall be closed off with a pipe cap supplied by the installer. When used as a drain, a trap or a valve should be used in the drain line.

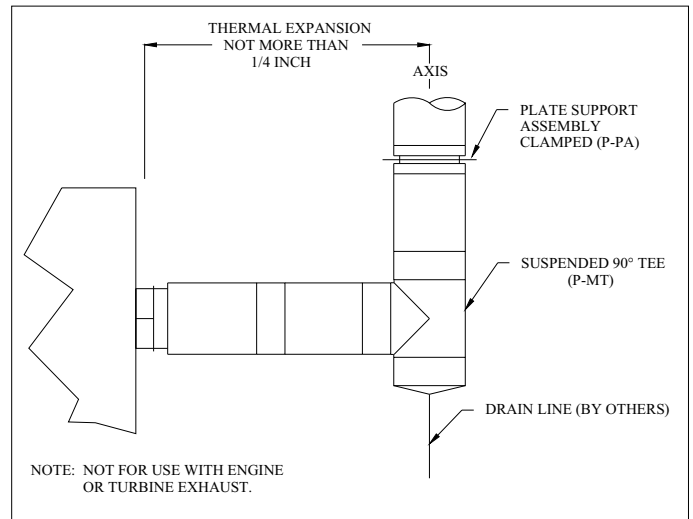
Always connect the drain fitting of the Drain Tee Cap to a suitable drain. This will allow rain entering the chimney to wash down, dilute and remove any corrosive combustion condensate. Also, always install the Tee Cap with sealant on mating surfaces of the flanged joint as well as in the groove of the Vee Bands. This will prevent leaks and assure that the drain functions as intended.

When placed on top of a supporting framework or flat plate, the Tee Cap closure becomes inaccessible and cannot be removed. Thus where access is desired into the tee or chimney, there are several options:

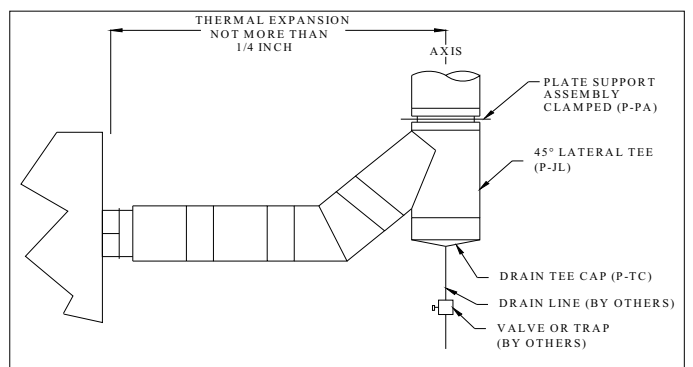
- a) Suspended Tee. Use a Plate Support Assembly (P-PA) or Wall Support Assembly (P-WA) at the upper tee joint or higher (see Fig. B-4a and B-4b).
- b) Support the Tee from its lower joint with a Plate Support Assembly (P-PA) and use an additional 18" pipe length below the Plate Support as a cleanout section to carry the Tee Cap (see Fig. B-3a and B-3b).

- c) Use a Wall Support Assembly above or below the Tee in the same manner as the Plate Support in step a) and b) above.

**Fig. B-1a – Single axis support for short lateral run**



**Fig. B-1b – Single axis support for short lateral runs**



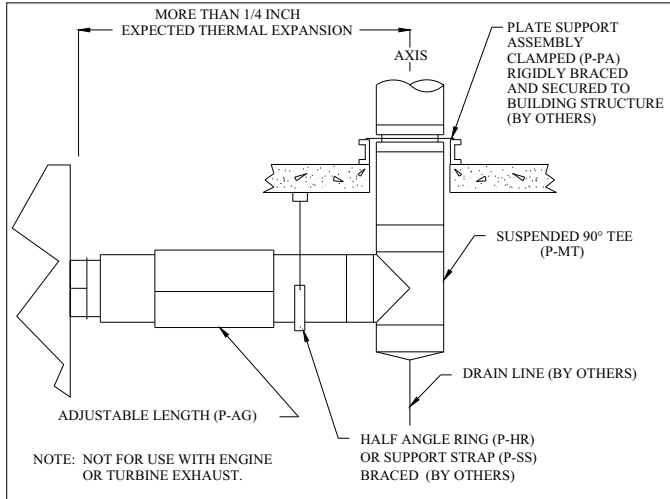
**THERMAL EXPANSION LENGTHS**

Based on temperature and length, if more than 1/4" of thermal expansion is expected in the horizontal run between an appliance connection and a tee, the use of two axis support (see Fig. B-2a and B-2b) is recommended. This enables the Adjustable Length to absorb expansion movement and prevents distortion or damage to the Tee. See Section C for complete thermal expansion design requirements and suggested details.

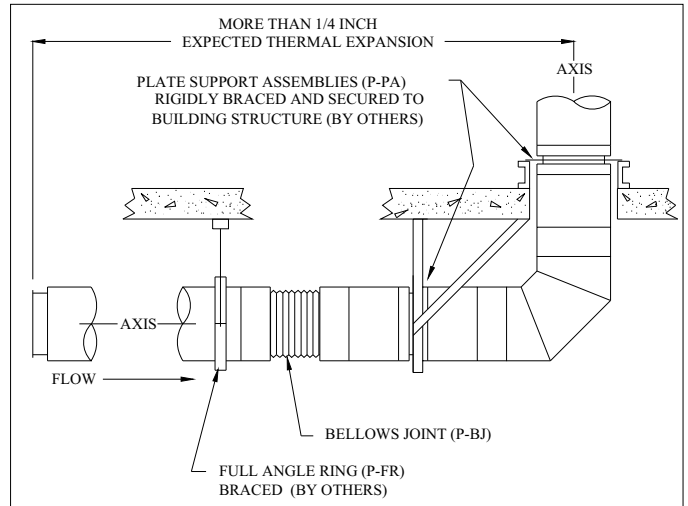
**Allowable lengths for 1/4" thermal expansion (see Fig. B-1a and B-1b).**

Gas Temperature Rise	Length
200°F	12'6"
300°F	8'4"
400°F	6'3"
500°F	5'0"
600°F	4'2"
700°F	3'7"
800°F	3'1"
900°F	2'9"
1,000°F	2'6"

**Fig. B-2a – Two axis support protects fittings from bending stress due to long lateral runs.**



**Fig. B-2b - Two axis support protects fittings from bending stresses due to long laterals**



**90° WYE (P-JY)**

The Wye fitting is useful where the vertical chimney must be located between two boilers, and a low pressure loss system is needed. The Wye fitting can also be used to make connections from engines with dual exhaust outlets into a larger single exhaust system. It may be suspended by a Plate or Roof Support, and the usual precautions for avoiding thermal expansion deformation must be observed for breechings and manifolds.

**INCREASERS: STEPS (P-OS) & TAPERED (P-OT)**

Where space is limited, the Step Inserter (OS) provides the necessary increase, in a lineal distance of 2 inches from end to end. It should be installed so as to avoid deflection from static loads or thermal expansion forces. This is a nonstructural part.

Tapered Inserters (P-OT) are made with a standard side angle of 14° (28° included angle of cone) for low pressure losses, and provide increases of one, two or three sizes. Length varies (see catalog) from 6 inches for the 6 x 8 size to 26 inches for 24 x 36 Tapered Inserter.

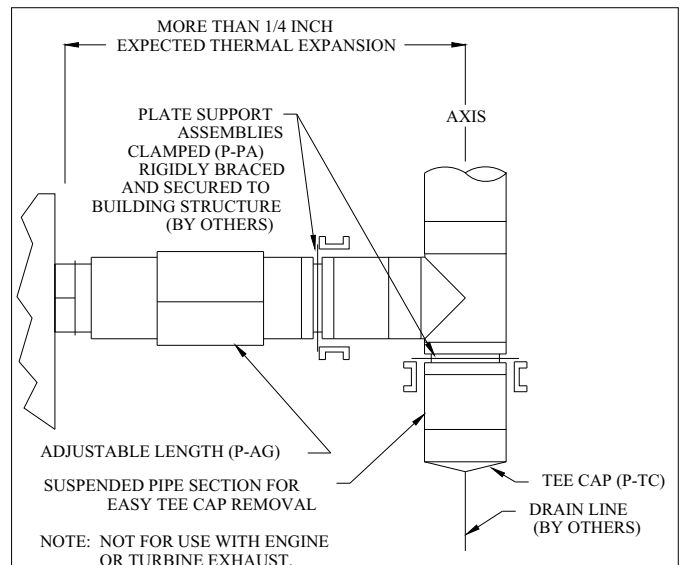
Outer jackets of Tapered Inserters are conical and span the distance between outer pipe jackets to maintain double wall construction. Tapered Inserters are considered to have the same strength in side and axial loads as straight pipe.

**ELBOWS**

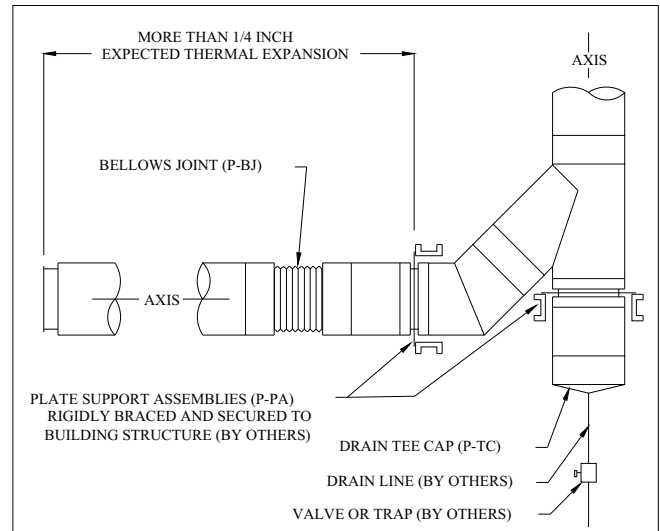
All Elbows feature the standard flanged Vee Band end joints. The 15° Adjustable Elbow is made in two halves, each with a 7 1/2° included angle and an internal flanged joint which can be opened and rotated from straight to the maximum 15° angle. For any angle adjustment, this Elbow provides a joint which can be used in tension or compression and sealed as necessary for the operating temperature and pressure.

The fixed 30°, 45° and 90° Elbows can be used to make up fixed 60°, 75° and 90° turns, and can be combined with the Adjustable Elbow for other angles. All elbows must be protected from thermal expansion and bending forces.

**Fig. B-3a - Two axis base support with Tee Cap Access**



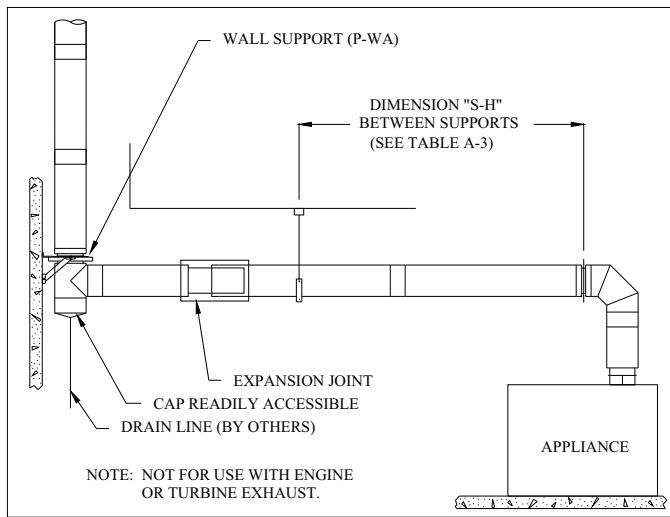
**Fig. B-3b - Two axis base support with Tee Cap Access**



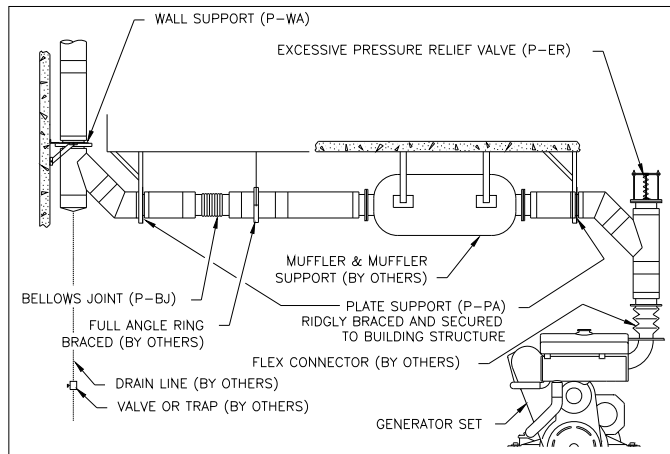
## USE OF ELBOWS, OFFSETS AND MANIFOLDS

Sloped or horizontal offsets in the vertical portion of a chimney above the breeching should be avoided except where absolutely necessary. Sloped offsets require more expansion joints and secure bracing above and below elbows. Special care should be exercised in designing the bracing for elbows because elbows (and fittings) can only take limited forces due to any bending moments. Structural parts such as posts or beams may also be needed to hold chimney supports in position (see Fig. B-6).

**Fig. B-4a - Tee suspended from Wall Support**



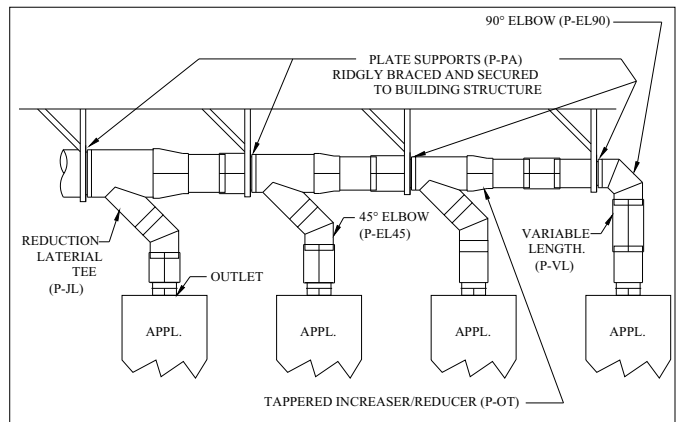
**Fig. B-4b - Lateral Tee suspended from Wall Support**



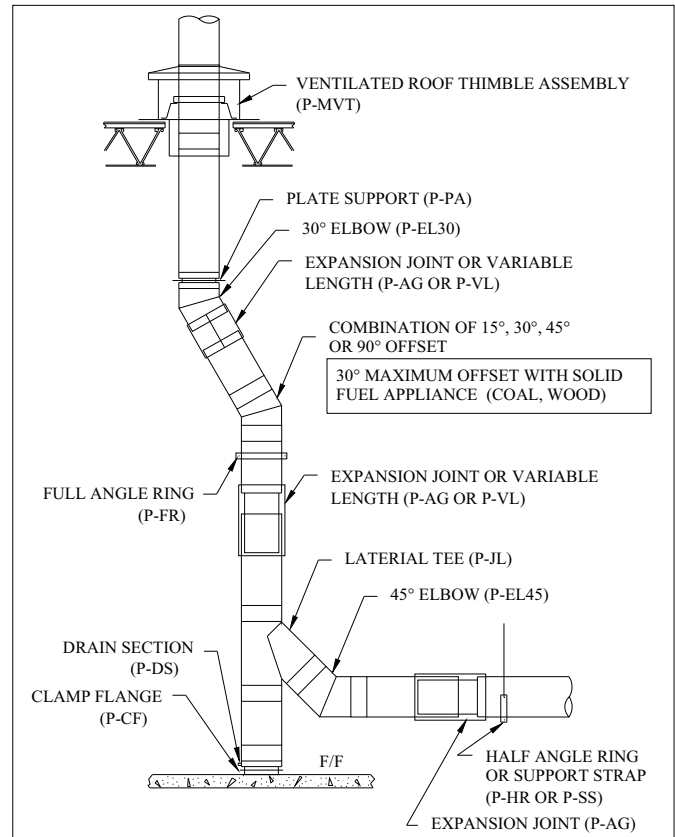
There is no limit on the angle or slope of an offset for gas or liquid fuel burning appliances, but with a solid fuel burning appliance the slope must not be greater than 30° from the vertical. Chimneys for combination fuel heating appliances which are capable of burning solid fuel or are convertible to solid fuel are limited to the same 30° slope even if the current choice of fuel is gas or oil.

The length of offset, if one is necessary, is determined by strength considerations. The maximum dimension between supports, given as the "S-H" Dimension in Table A-5 of these instructions, is applicable to all horizontal and sloped orientations. To assure proper guidance of expansion joints and to prevent unnecessary joint bending, use an adequate number of supports such as Full Rings, at closer intervals.

**Fig. B-5 - Multiple appliance manifold using 45° Tees**



**Fig. B-6 - Base Supported Stack with Offset**



When it is necessary to provide additional structural stiffening at the elbows or fittings, rigidity can be provided by using an additional Plate Support Assembly (See Fig. B-7) located at the other end of the elbow or fitting and bolting lateral braces across the corners using standard brackets.

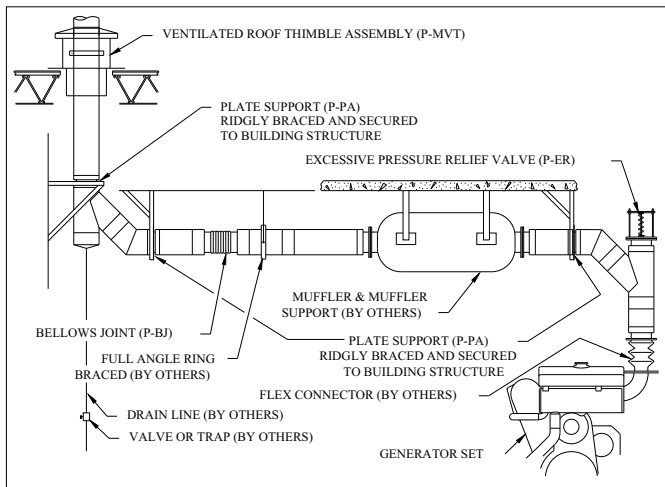
With frequent resupport, there is no structural or operating limit to the length of horizontal or sloped portions of a Model VSI/IVSI chimney, providing the system meets the capacity, pressure drop or available draft requirements of the appliance or equipment. The carrying capacity of Model VSI/IVSI supports and their structure attachments must consider the weight of the offset plus whatever vertical pipe is carried by that support. Height limits for supports are tabulated in Section A of these instructions.

The ends of any sloped or horizontal offset must be anchored to prevent overstressing elbows and to assure proper operation of expansion joints. The vertical sections of chimney above the offset must also be supported or anchored and guided where necessary. Model VSI/IVSI Roof Supports, Ventilated Thimbles, Wall Supports, Plate Supports, Wall Guides and Full Rings may be used in a variety of ways for offset support to obtain a structurally stable chimney system. Selected methods of using Model VSI/IVSI supports are shown in Fig. B-7, B-8.

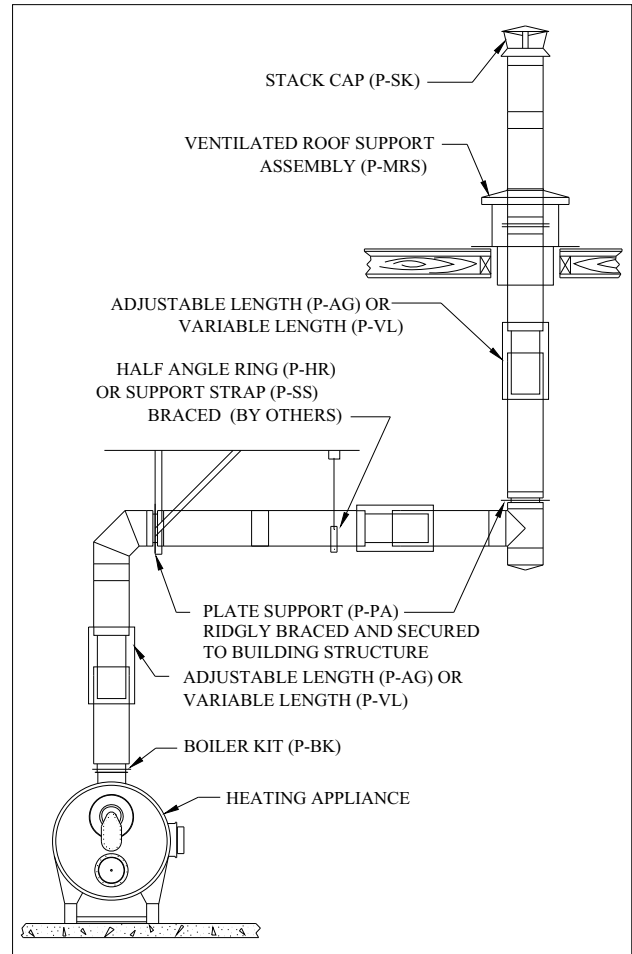
Resupports must be securely anchored to walls, posts, or locally fabricated rigid framework. This framework must be designed to assure stability of attached Model VSI/IVSI supports, such as Plate Supports and Wall Supports. Supports suspended by threaded rod or from small size angles or straps are usually not satisfactory to resist bending moments due to offsets. The horizontal portion of a Model VSI/IVSI chimney system between the appliance and the vertical chimney is defined by most building codes as a "connector", and such connectors may be horizontal without any impairment of system function. Frequently in boiler or equipment rooms, headroom is limited and there is generally some access for inspection and maintenance. Thus horizontal breechings or manifolds using Model VSI/IVSI are not subject to any fuel restrictions.

The 30° limitation on offset slope for solid fuels also does not apply to breeching or manifolds in the boiler equipment room.

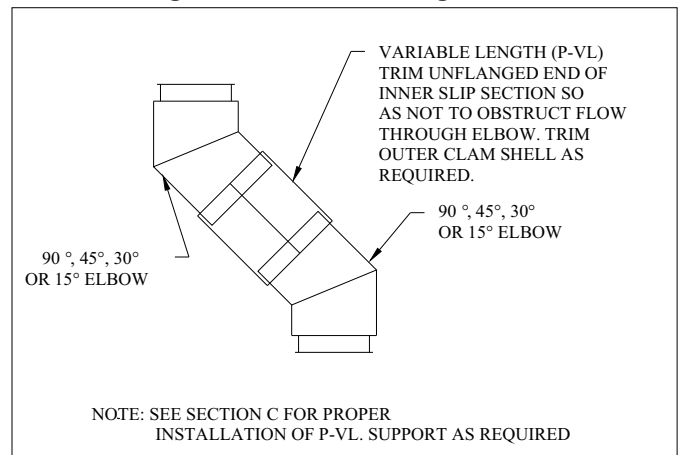
**Fig. B-7**



**Fig. B-8**



**Fig. B-9 Short Offset using a P-VL**



## THERMAL EXPANSION

The inner pipe of Model VSI/IVSI is load bearing and its thermal expansion is the same as that of a continuous pipe. A simplified rule for exhaust pipe expansion estimation is that the axial growth will be approx. 1" per 100' of pipe length for each 100°F the flue gas temperature is above the surrounding air temperature.

When assembled in any orientation, the amount of thermal expansion of the inner pipe is directly dependent on the inner wall temperature and the length of pipe between fixed points. Good installation practice requires that expansion greater than 1/4 inch will be compensated for using a Bellows Joint or Adjustable Length, depending on the maximum pressure encountered.

The flanged inner piping joints have negligible flexing capacity, and in addition, tees and elbows are not designed to withstand bending moment forces. Because the amount of outer casing axial movement is the same as inner casing movement, the outer jackets of piping must slide to avoid excessive forces on tees, elbows or fixed points. To accommodate outer casing movements, external guides along walls at floors, or in lateral breechings, must allow for movement of pipe.

NOTE: When resupporting a high rise exhaust system, Adjustable Lengths (AG) or Bellows Joints (BJ) must be used just below every support above the first to compensate for thermal expansion. For engine and turbine exhaust systems requiring pressures to 60 inches of water column, or where the construction must be absolutely gas tight, all welded Bellows Joints (BJ) are recommended for expansion and vibrational movements of the exhaust piping. Out-of-doors construction or low pressure systems, such as boilers (to 6 inches of water column), can effectively use the Adjustable Length (AG).

Spacing of guides and supports, when a thermal expansion part is used, should be not greater than specified in Section A. Proper guiding and support of expansion parts often requires closer spacing.

## BELLOWS JOINTS: LINED (BJ)

For exhaust pressure to 60 inches of water column, Bellows Joints are recommended for expansion and vibrational movements of the piping. See Fig. C-2 for an illustration of a Bellows Joint (BJ).

Fig. C-1 illustrates the use of Bellows Joints in a typical installation. The use of the Lined Bellows Joints (BJ) is shown to compensate for the axial expansion of the long horizontal run.

The Lined Bellows (BJ) has a 0.035" thick or heavier straight stainless steel liner to protect the thinner Bellows material from heat and flow effects. It is used anywhere in a system for axial and vibrational movements only and must be accurately supported and guided. This part has limited lateral movement (1/8" max.) and lateral offsets and parallel misalignments should be eliminated. The purpose of the liner is to minimize contact, smooth flow, control erosion and eliminate resonance caused by exhaust gases passing through the bellows.

The Lined Bellows requires careful placement of piping guides to avoid interference on thermal expansion. Bellows should not be installed w/ any compression, but at its full uncompressed length in ambient state.

Fig. C-1 - Location of Bellows Joint in Typical System

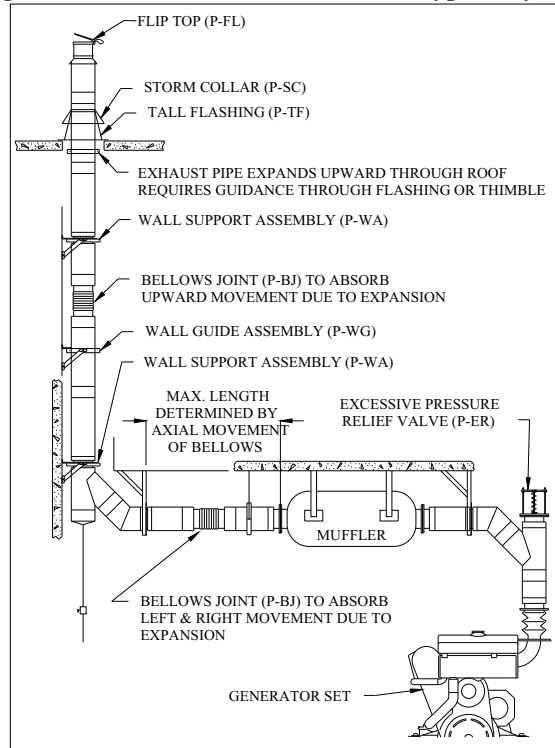
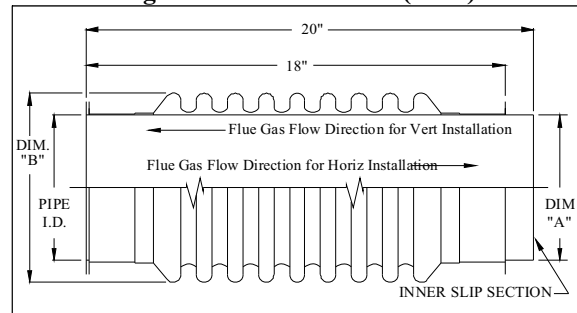


Fig. C-2 - Bellows Joints (P-BJ)



Pipe I.D.	Dim. A Stub End O.D.	Dim. B O.D.	Bellows No. Conv.	Mat'l Thick-ness	Axial Spring Rate (Lb/in)	Axial Compr.
6"	6.07"	7.10"	16	0.012"	113	3.0"
8"	8.07"	9.25"	12	0.012"	116	3.0"
10"	10.07"	11.25"	12	0.012"	125	3.0"
12"	12.07"	13.25"	22	0.018"	153	3.0"
14"	14.07"	16.25"	11	0.018"	158	3.0"
16"	16.07"	18.25"	11	0.018"	161	3.0"
18"	18.07"	20.25"	11	0.018"	180	3.0"
20"	20.07"	22.25"	11	0.020"	210	3.5"
24"	24.07"	26.50"	11	0.020"	250	3.5"
28"	28.07"	30.50"	11	0.020"	290	3.5"
32"	32.07"	34.75"	9	0.025"	553	3.5"
36"	36.07"	38.75"	9	0.025"	620	3.5"
42"	42.07"	44.75"	9	0.025"	710	3.5"
48"	48.07"	50.75"	9	0.025"	819	3.5"

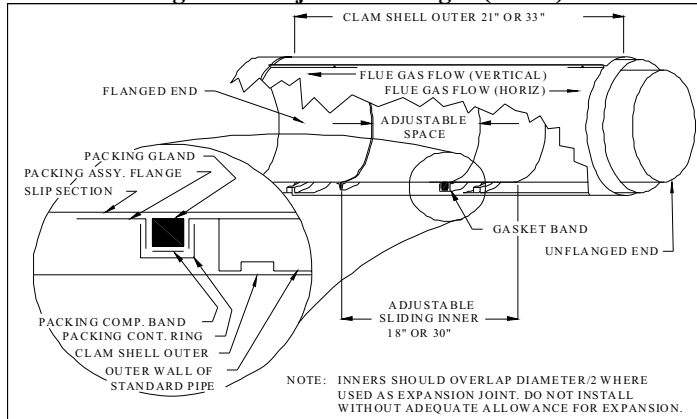
For any VSI/IVSI piping system requiring low axial expansion forces the Bellows Joints (P-BJ) will deflect with minimum friction at a known "spring rate." The values for spring rates given in the table assumes there are no other frictional constraints and proper alignment of the liner of the (P-BJ).

At an operating gas temperature of 1000°F (70°F, ambient) the VSI inner pipe in a typical engine exhaust system will be at a temperature rise of approximately 750°F. The same 1,000°F gas temperature will create higher inner pipe temperatures for model IVSI because it is better insulated.

Allowable expansion movements for Bellows Joints BJ are given in Figure C-2. For the following Bellows sizes, estimated cycle life is 6" - 12" = 4000 and 16" - 36" = 30,000 at 750°F.

The system operating pressure of 60 inches water column (2.08 psi) is based on the estimated capability of ceramic sealed Vee Band joints. The actual pressure limit of the welded bellows will be 10 psi for 6" to 12" diameter and 5 psi for 16" to 48" diameter at 750°F.

**Fig. C-3 - Adjustable Length (P-AG)**



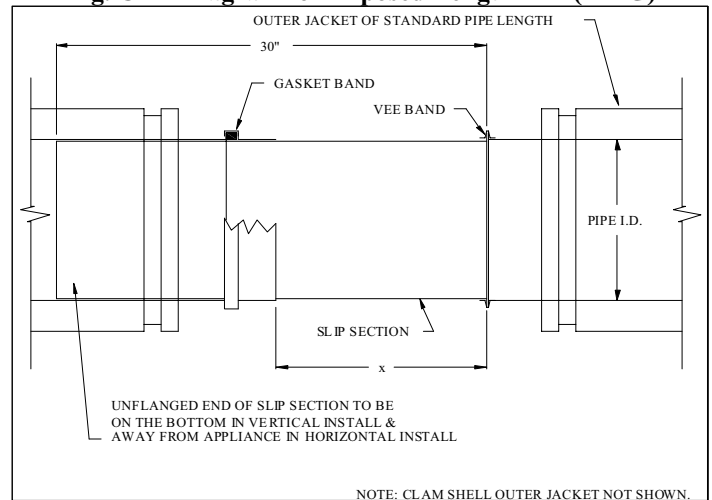
**ADJUSTABLE LENGTH (P-AG)**

The Adjustable Length has two major functions: To make up odd lengths of pipe as needed in short runs, and to serve as an expansion joint for thermal expansion in longer runs of pipe. The Adjustable Length may be used when pressures do not exceed 6" water column or in well ventilated areas. When used in systems of any orientation, it can perform both functions simultaneously.

The Adjustable Length comprises a sliding inner section, flanged on one end only (see Fig. C-3). This sliding piece is sized to fit closely inside a standard pipe section. At the sliding joint the assembly as shipped is fitted with a special graphited packing seal. The sliding outer jacket is the same thickness as that used on piping outer casings. It is placed around the sliding inner joint and must also slide in order to avoid expansion stresses.

For proper installation, an Adjustable Length must have adequate overlap and sufficient allowance for thermal expansion movement (see Fig. C-4). An Adjustable Length sliding inner pipe may be trimmed to ensure correct mating to a fitting or other short part. Care must be exercised so that proper penetration is maintained at low temperatures and no interferences occur at high temperatures.

**Fig. C-4 - Diagram for Exposed Length "X" (P-AG)**



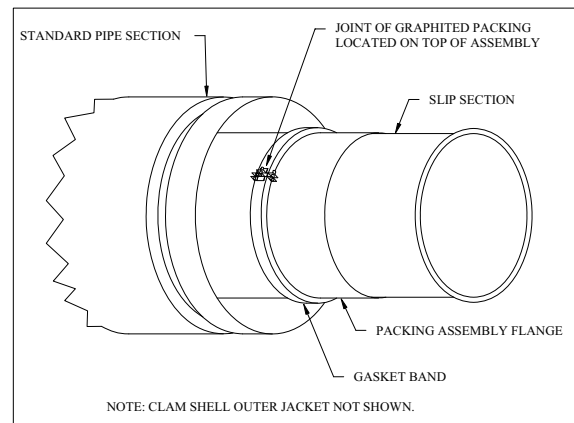
Maximum "X" Dimension	
Pipe Size	6" 8" 10" 12" 16" 20" 24" 28" 32" 36" 42" 48"
Max X	25.5" 24.5" 22" 21" 19" 17" 15" 13" 11" 9" 7.5" 4.5"

Minimum "X" Dimension	
Operating Temperature*	200 300 400 500 800 1000 1200 1400
Min X for 50' Length	0.7" 1.2" 1.7" 2.2" 3.7" 4.7" 5.7" 6.7"
Min X for 100' Length	1.4" 2.4" 3.4" 4.4" 7.4" 9.4" 11.4" 13.4"

\* Temperature of 60°F assumed at time of installation, thus a temperature of 400 is a 340° rise and 100 feet will expand 3.4 inches. 30ft of pipe would expand: (30/100) \* 3.4 = 1"

**Fig. C-5.**

**Gasket Band assembled on Adjustable Length (P-AG)**

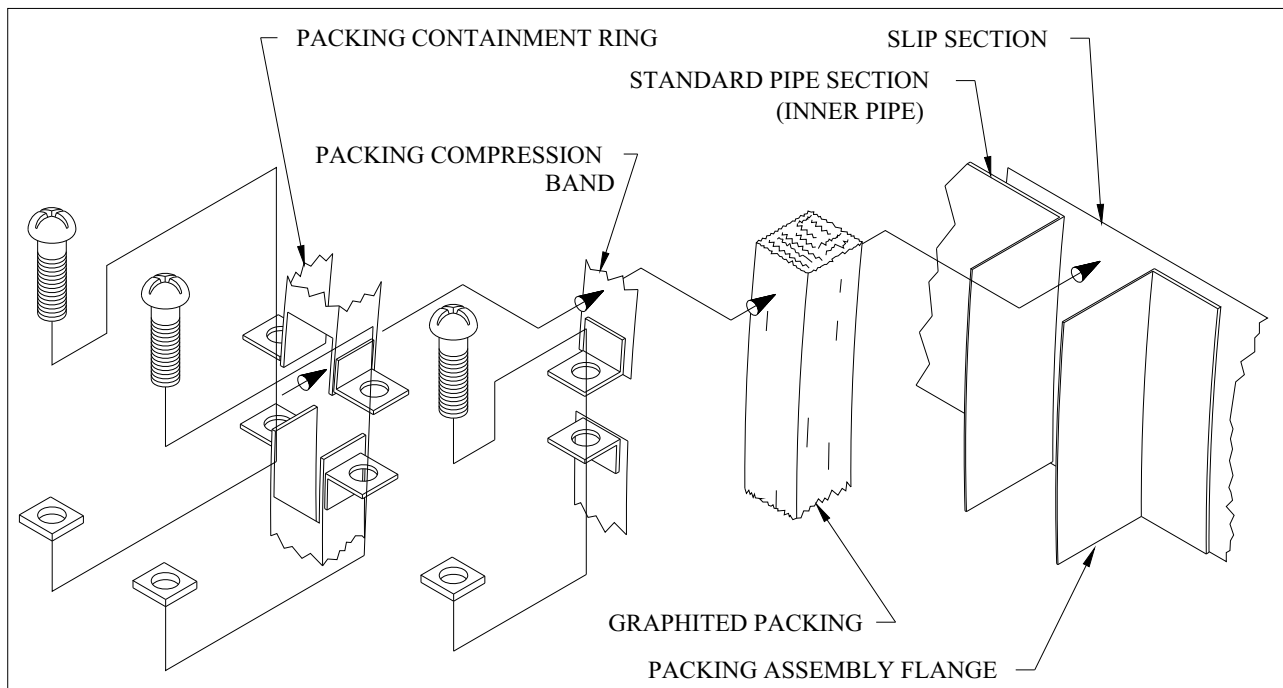


**VERTICAL INSTALLATION OF BELLOWS AND ADJUSTABLE LENGTHS**

When a Bellows Joint (P-BJ) or an Adjustable Length (P-AG) is installed in a vertical position between two fixed points, such as between a P-PA and a P-MRS, it should be installed immediately below or one pipe length below the higher support. To assure proper axial alignment, guides (P-WG or P-FR or P-FG) must be installed at the pipe section below the bellows or adjustable length (see Fig. C-1). This combination of parts will assure proper movement of bellows and adjustable lengths and thus relieve loads due to thermal expansion. It is desirable to install bellows and adjustable lengths near the top of a vertical section to ensure that they do not bottom out during installation and thus become ineffective at relieving thermal expansion loads. This arrangement of parts will also resist wind loads on installations which run up building exterior walls.



**Fig. C-6. Gasket Band Assembly Parts for Adjustable Length (P-AG)**



#### HORIZONTAL INSTALLATION OF BELLOWS AND ADJUSTABLE LENGTHS

Horizontal or sloped installations of Bellows (P-BJ) or Adjustable Lengths (P-AG) use the same parts, assembled in the same relationship, as a vertical assembly. These expansion joints, when required may be placed anywhere between two fixed points of horizontal or sloped installation as long as they are properly guided, properly supported; and for sloped installations in particular, as long as bottoming out is prevented. It is recommended, but not required; that the Lined Bellows inner shield and the Adjustable Length sliding inner be attached to the upstream end of a horizontal installation (the free end is downstream, away from appliance). When the adjustable is put in place for horizontal runs, the packing joint must be on the top of the pipe (see Fig C-4).

#### ADJUSTABLE LENGTH PACKAGING

Adjustable Lengths are shipped with their outer pipe clam shell jacket inside the sliding inner pipe. The gasket band assembly is preassembled at shipment on the inner pipe. It only needs to be loosened for attachment to an adjacent piece of pipe and then tightened for a leak resistant fit. (See "Thermal Expansion" in this section.)

#### INSTALLATION OF ADJUSTABLE LENGTH PACKING

Normally, disassembly of the Adjustable Length is not necessary; but if the gasket band must be removed for any reason, it can be reassembled using the following procedure. (Some of this procedure can be done with the hardware conveniently placed on the floor. Performing this procedure with the Adjustable Length in this position could be difficult for a person working alone.)

a) Prepare the sliding inner section for assembly by placing the packing assembly flange over the sliding inner section (Refer to Fig. C-3, C-5, and C-6 for a description of all parts involved.) Make sure the packing assembly flange is

oriented correctly.

- b) Place the sliding inner slip section into a standard section of IVSI Duct.
- c) Wrap the graphited packing around the slip section of the Adjustable Length between the standard section pipe flange and the packing assembly flange. (Using an ordinary staple to hold both ends of the graphited packing together aids in the assembly.)
- d) Clearly mark on the packing assembly flange the location of the joint of the graphited packing. (See Fig. C-5 for the ultimate location of the joint.)
- e) Slide the packing assembly flange toward the standard section inner pipe flange so that graphited packing is captured between those two flanges.
- f) Place the packing compression band around the graphited packing with the graphited packing joint located at the midpoint of either half of the band. Tightly secure the compression band with the hardware provided, but Do Not Over-tighten.
- g) Both halves of the packing containment ring can now be placed over the graphited packing and compression band so that the compression band joints are exposed at the notched-out section at the ends of the containment ring halves (See Fig. C-6).
- h) Fasten both joints of the containment ring with appropriate hardware and secure (Do not over-tighten because the sliding inner must still remain movable.)
- i) This whole assembly can now be put in place, extended to its correct length and secured with a Vee Band.
- j) Tighten both joints of the compression band so that the graphited packing is firmly registered against the sliding inner.
- k) Retighten both joints of the containment ring.
- l) Install the outer pipe covering jacket (and insulation strip if IVSI) so it fits loosely and can slide freely when the duct expands or contracts.

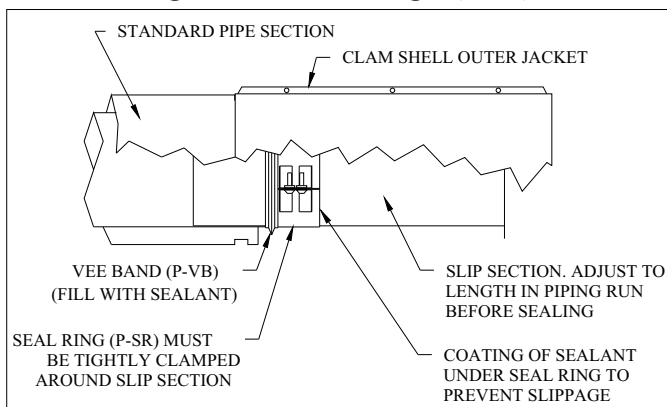
## VARIABLE LENGTH (P-VL)

In straight runs of Model VSI/IVSI, the Variable Length serves two major functions: 1) to make up for odd lengths of pipe in short runs, and 2) to provide for joint sealing. This part adjusts to a needed fixed exact length. Its internal joint must be sealed by working sealant under the seal ring, as well as between this ring and the flange to be joined by the Vee Band (See Fig. C-8).

Observe all precautions for cleaning surfaces to be sealed and carefully follow the Variable Length installation procedures specified below.

The Variable Length comprises a sliding inner section, flanged at one end only. This sliding piece is sized to fit closely inside a standard pipe section. A seal ring is provided to prevent the inner section from slipping after assembly. The sliding outer jacket is aluminized steel of the same thickness as that used on piping outer casings. It is placed around the assembled inner and finishes the appearance of the Variable Length. For detailed methods of installation see instructions contained below in this section.

**Fig. C-8 - Variable Length (P-VL)**



## SHORT AND ODD LENGTHS ADJUSTABLE LENGTH (P-AG) AND VARIABLE LENGTH (P-VL)

The following data is for any Pressure Stack system where a short length (4" to 26") is needed. This applies in horizontal runs between the appliance and tee, between two fittings, and similar situations. For gaps of 4" to 26" both the inner and outer pipes of the Adjustable Length may need to be trimmed. The Variable Length has a corresponding gap 4" to 26".

Observe these steps in making up a short length assembly for the Adjustable Length.

1. If the Adjustable Length has been pre-assembled into a standard pipe section, disassemble carefully, observing the position of the gasket band and the gasket.
2. For Adjustable Lengths shipped unassembled, refer to Fig. C-4 prior to starting any cutting.
3. Check both the foregoing table and the Adjustable Length table prior to cutting, and make sure that the inner pipe is as long as possible with due allowance for thermal expansion. The outer pipe should be 3 inches longer than the inner.
4. Cut and finish the pipe ends carefully to avoid burrs which would interfere with reassembly or thermal expansion movements.
5. Assemble the inner section and gasket band in

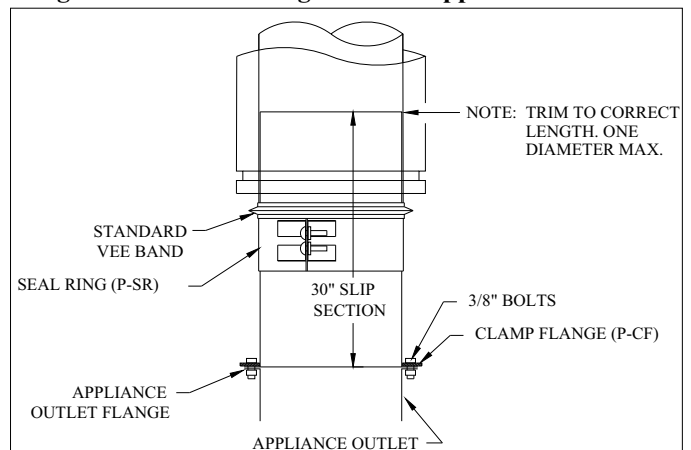
accordance with Fig. C-4, checking again for possible interference.

6. Check the fit of the gasket to be sure there are no gaps between it and the inner pipe.
7. Install outer pipe (and insulation strip if model IVSI). It may face the same or the opposite direction of the inner, providing there is adequate room for expansion movement.

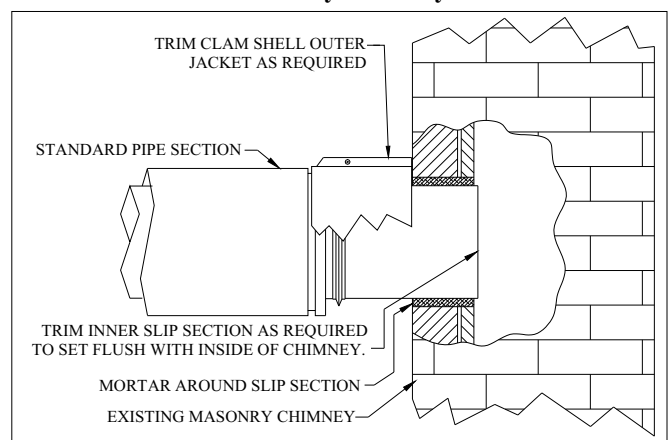
Observe these steps in making up a short length assembly for the Variable Length:

1. Prior to installation in the run of chimney, clean the Vee Band and surfaces to be cemented.
2. Install slip connection and adjust to length in run.
3. Install sealed Vee Band, joining flanged end of slip section to next length of pipe.
4. Work in sealant between slip section and its external section of pipe.
5. Apply thin layer of sealant to inside of Seal Ring.
6. Position Seal Ring as shown in Fig. C-3 and clamp tightly before cement sets.
7. Fill Vee Band with sealant and install over flanges of joint between pipe and Seal Ring.

**Fig. C-8 - Variable Length used as appliance connector**



**Fig. C-9 - Variable Length used to terminate into an existing Masonry Chimney**



### Structural Support and Guiding

#### PLATE SUPPORT ASSEMBLY (P-PA)

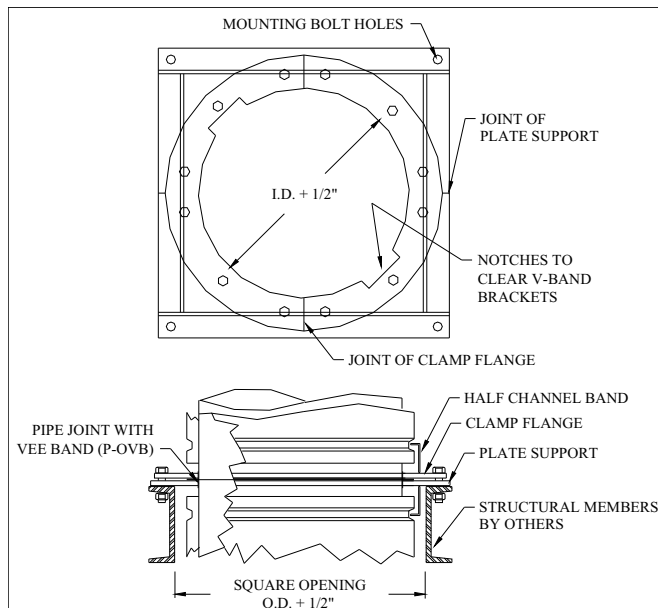
The Plate Support Assembly consists of a Clamp Flange (P-CF) (located above the Vee Band), bolted into a Plate Support (located below the Vee Band). The clamping force between these parts is applied to the Vee Band. The Plates secured to structural steel framing thus, the assembly and the pipe are anchored against upward, downward and angular displacements. Joints of the plates and flanges must be located 90° apart, with notches aligned for relief at Vee Band end clips.

The Plate Support Assembly is the maximum strength support for a vertical VSI/IVSI chimney. It is also used to maintain positive joint alignment and support for expansion joints in horizontal chimneys. Between any two fixed points in a system or wherever an expansion joint must slide to prevent bending of tees or elbows, locate and secure Plate Support Assemblies as necessary by means of structural ties to the building. This may require supports both upstream and downstream of a tee, which then protects the tee from excessive bending stresses.

Support height limits for plate assemblies are given in Section A of these instructions.

Greater stability may be obtained by resupporting above with additional Plate Support Assemblies, using an Adjustable Length or Expansion Joint below each point of Support. To obtain these strengths, all holes must be bolted with 3/8 inch bolts (see Fig. D-1).

**Fig. D-1 - Plate Support Assembly**



**Plate Support Height Limits:  
See Section A**

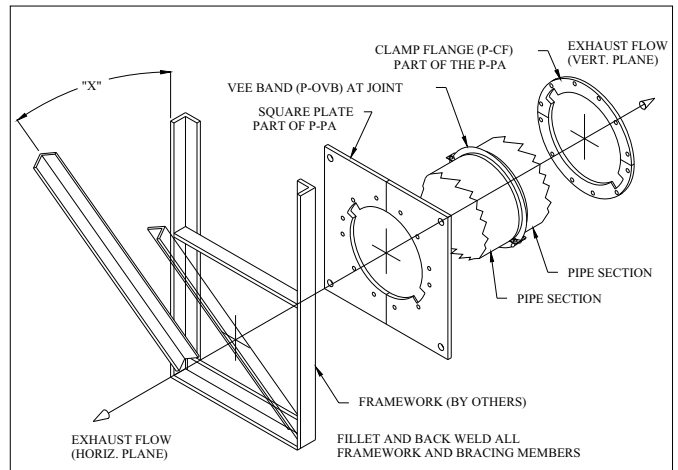
The notches in the Plate Support and in the Clamp Flanges are to accommodate Vee Band end clips, thus allowing the Vee to rest solidly on the Plate. The bolt circle and spacing of the plates and flanges are identical, providing a variety of options in supporting and reinforcing a chimney.

The Plate Support method is intended only for

attachment to NONCOMBUSTIBLE surroundings such as steel structure, concrete block or other masonry at clearances adequate for access and assembly. Heat conduction through supporting brackets can be reduced by use of spacers such as insulating millboard. The Plate Support is not suitable for attachment to wood or combustible walls. Exception: In an L Vent application, the PA may be attached to wood framing if non-combustible millboard is placed between the two surfaces.

The Plate Support Assembly must be secured to the building with a rigid structural framework. Under no circumstances should a plate support be secured with threaded rods since this will not prevent pipe sway. See Fig D-2 for proper bracing techniques.

**Fig. D-2 - Plate Support Bracing**



Satisfactory performance and long service life of Model VSI/IVSI systems requires the product be rigidly braced and supported. Every installation presents unique support and bracing requirements and the following guidelines will provide minimum acceptable sizes for the mechanical hardware supplied by others.

Note: IF BRACING IS USED, MINIMUM "X" ANGLE (IN FIG. D-2) IS 30°. IF BRACING IS NOT USED, WELDED FRAME MEMBERS MUST BE ATTACHED TO STRUCTURAL MEMBERS TO PROVIDE EQUIVALENT RIGIDITY OF FRAMEWORK.

Pipe Size	PA Thickness	Framework (in.)	Bracing
5" – 20"	3/16"	2x1x3/16 to 5x1-3/4x3/16 Channel or equivalent	2x2x3/16
24" – 36"	1/4"	5x1x3/4 to 6x2x5/16 Channel or equivalent	3x3x1/4
42" – 48"	3/8"	6x2x5/16 Channel or equivalent	4x4x3/8

#### CLAMP FLANGE (P-CF)

The heavy steel Clamp Flange is pre-drilled with bolt holes to match those in the plate Support and the Full Ring. Each Flange half has a notch for relief at Vee Band clamp locations.

The Clamp Flange may be used to hold down an Adjustable or standard pipe length on a round flanged appliance outlet. Holes for 3/8" bolts should be drilled as necessary, or one set of flanges may be welded to the top of the boiler flange, with the other set used around the inner pipe above the pipe flange. The inside diameter of the Clamp Flange is not intended to fit below a round boiler outlet flange.

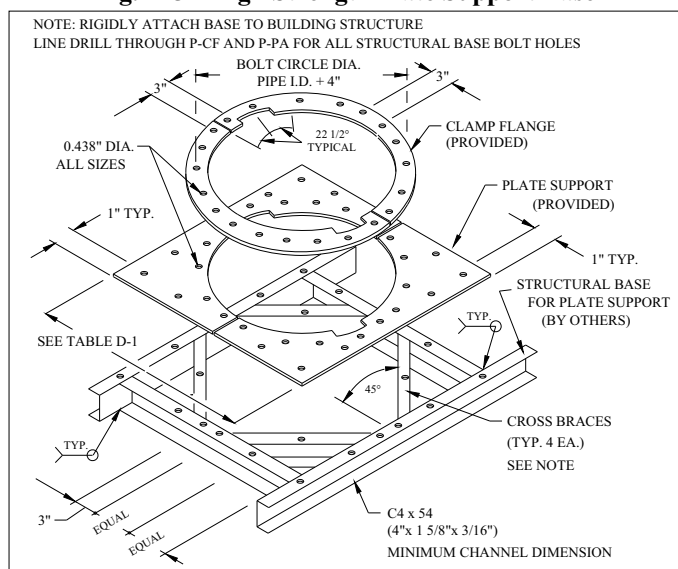
When used in this manner at a boiler outlet, the inner cutouts should be filled with suitable refractory cement.

The Clamp Flange may be used as a hold down on a refractory base or oven, given the proper size opening hole for support and correctly placed bolts or masonry anchors. See Model VSI/IVSI System Catalog for Clamp Flange dimensions including bolt circle dimensions.

### HIGH STRENGTH PLATE SUPPORT BASE

Greater height limits and stability can be gained for pipe sizes over 20 inch diameter by using a High Strength Plate Support Base as shown in Fig. D-3. The structural base as shown has been tested by Underwriters' Laboratories, Inc. and has a minimum factor of safety of 4. Follow all of the design guidelines illustrated in Fig. D-3 to obtain maximum strength in the assembly. Rigidly attach the assembly to the support structure. To minimize construction time and assure alignment of all parts, use the plate support as a template and predrill the bolt holes in the structural base.

**Fig. D-3 - High Strength Plate Support Base**



**Table D-1. P-PA Assembled Overall Size**

Insulation Thickness/Size	PA Size (in.)	Bolt Circle dia.(in.)
VSI & IVSI-C1	Pipe Size + 6"	Pipe Size + 4"
IVSI-C2	Pipe Size + 8"	Pipe Size + 6"
IVSI-Z3	Pipe Size + 10"	Pipe Size + 8"
IVSI-C4	Pipe Size + 12"	Pipe Size + 10"

### WALL SUPPORT ASSEMBLY (P-WA)

The Wall Support Assembly consists of a Full Angle Ring, Brackets and Struts, plus two Clamp Flanges. These Flanges are clamped over and under the Vee Band of an inner joint, and against the Ring for secure attachment to the inner chimney pipe, as shown, in Fig. D-4.

To assemble the two Flanges and Ring, use the Clamp Flange in the middle, to hold the outer parts together by placing it to span the split in the Ring. To provide clearance for the clamp ends of the inner band, the 4 inch wide notches of both Clamp Flanges should be in alignment and 180° apart. All holes

should be completely and tightly bolted, using the hardware provided. Full strength is attained with this assembly whether the Ring is located above or below the joint being supported (see Fig. D-5).

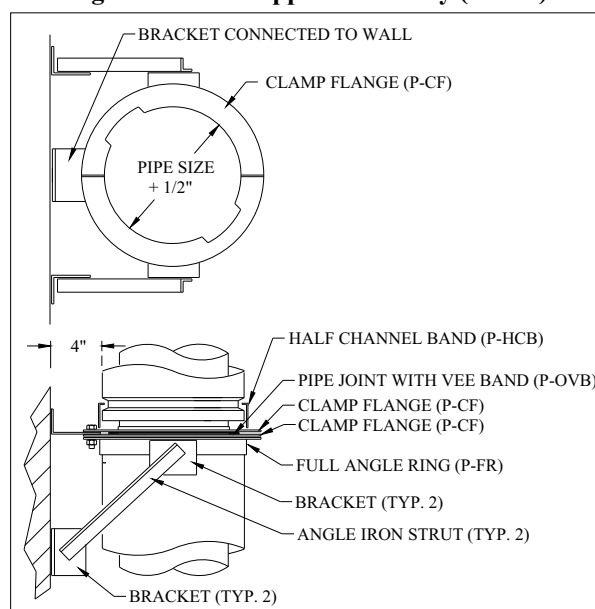
When attached to a masonry wall or suitable non-combustible structure, the Wall Support forms a fixed point in the chimney system, thus expansion movement above and below must be considered during system planning.

The Wall Support Assembly is suitable for use as the support just below the point where the chimney becomes freestanding. For such use, a Full Angle Ring or Wall Guide Assembly should be installed a distance of 6 to 10 feet below the Wall Support. This stabilizes the exposed end and thus resists side forces due to wind (see Fig. D-6).

VSI and IVSI C-1 Wall Supports may be used at 30 foot spacings. Use IVSI C-2 Wall Supports at 20 foot spacings for chimney resupport. Use appropriate expansion joints and Full Rings or Wall Guides for lateral stability at appropriate spacings. The height of a chimney between supports is measured from the Adjustable Length, which must be used below each support.

Clearance from a non-combustible wall to chimney outer casing varies slightly with the size of the Wall Support, but will be between 4 and 4-1/2 inches.

**Fig. D-4 - Wall Support Assembly (P-WA)**



### WALL GUIDE ASSEMBLY (P-WG)

The Wall Guide Assembly (P-WG) comprises a Full Angle Ring (P-FR) plus brackets, angle struts and hardware for assembly (but does not include anchor bolts for attachment to a wall). The Ring, which is split in two halves for ease of assembly, is 1/8 inch larger than the outside diameter of the chimney pipe to allow for sliding movement during thermal expansion. In any Guide application the proper position of the Ring, when assembled around any pipe section, is at a joint but below the outer band. This allows the outer band to move away from the Ring.

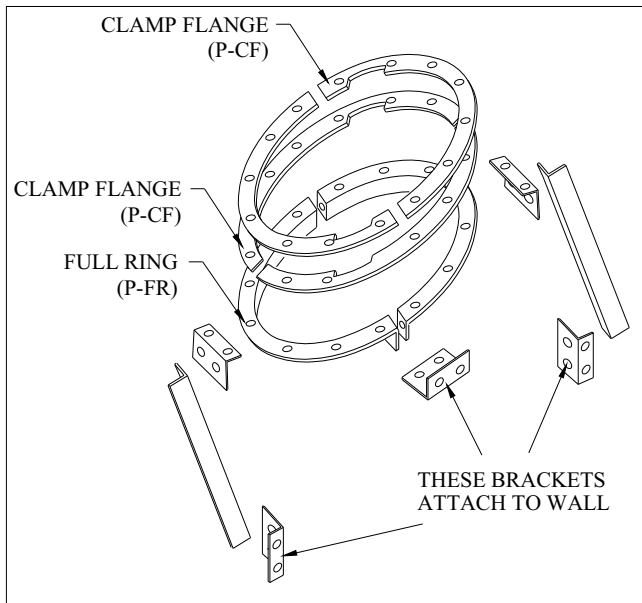
The Wall Guide Assembly (P-WG) is designed for 2 to 10 inches of clearance from pipe outer casing to noncombustible walls. The side struts may be placed either up or down as convenient.

This Assembly is intended to resist lateral or side loads only, and is not for carrying the weight of a vertical chimney.

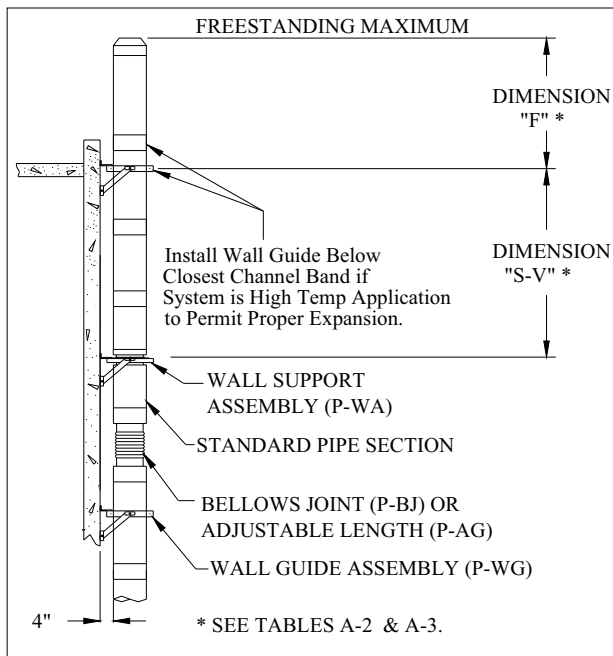
The horizontal struts allow for attachment to the wall after the chimney has been positioned. The angle of attachment may vary as needed for the chimney-to-wall clearance.

The Wall Guide Assembly is not for attachment to wood walls, wood structure or other combustible materials. If the stack must be attached to an interior or exterior combustible wall, spacers should be used to maintain proper clearance and minimize heat conduction through supporting metal parts.

**Fig. D-5 -Exploded view of Wall Support Assembly (P-WA)**



**Fig. D-6 - Upper end of exhaust system using Wall Support (P-WA)**

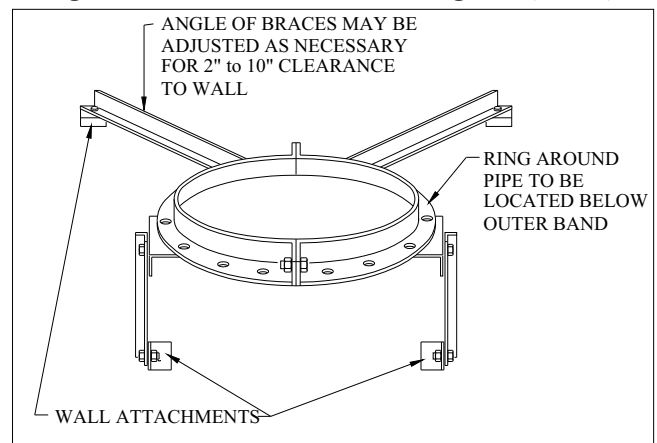


**Note: Important - Location of Wall Guides and Full Rings on Tall systems serving as engine exhaust or other high temperature applications.**

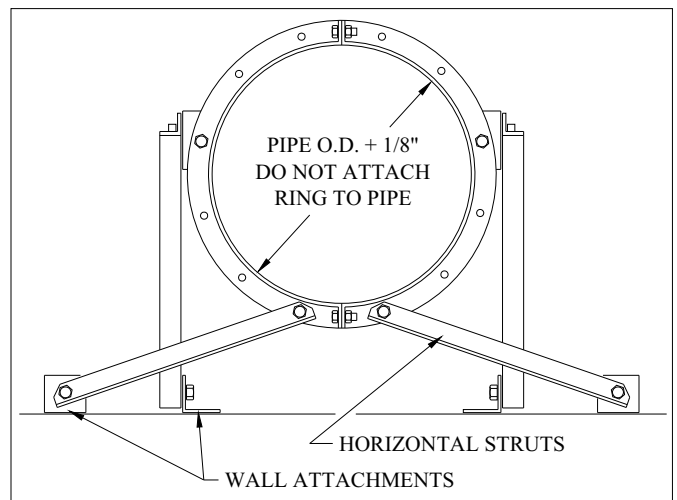
In order to avoid potential problems due to thermal expansion, Wall Guides (P-WG) and Full Rings (P-FR) on tall engine (and other high temperature) exhaust systems must ALWAYS be installed at an elevation BELOW the closest Channel Band (P-CB).

Mistakenly installing a WG or FR directly (or some minimum distance) above a Channel Band could result in obstruction of the natural vertical "growth" in height of the system when the appliance is operated and result in physical damage. Contact the factory if there are any questions. (See Fig D-6)

**Fig. D-7 - View of Wall Guide, facing wall (P-WG)**



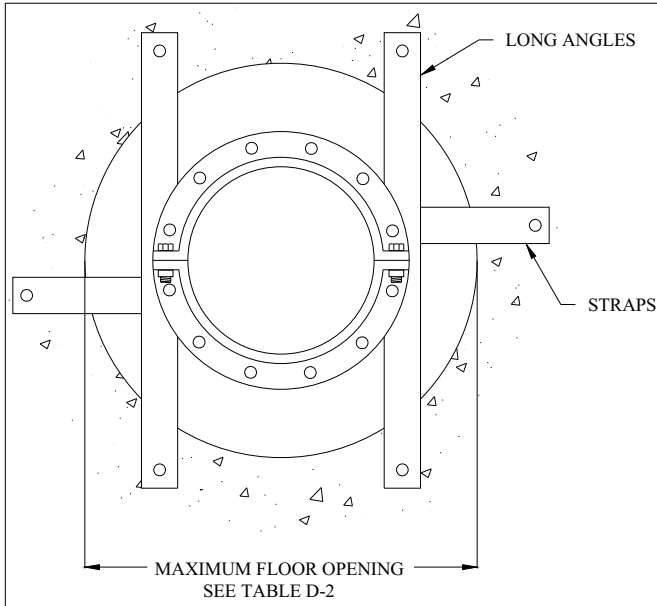
**Fig. D-8 - Plan view of Wall Guide (P-WG)**



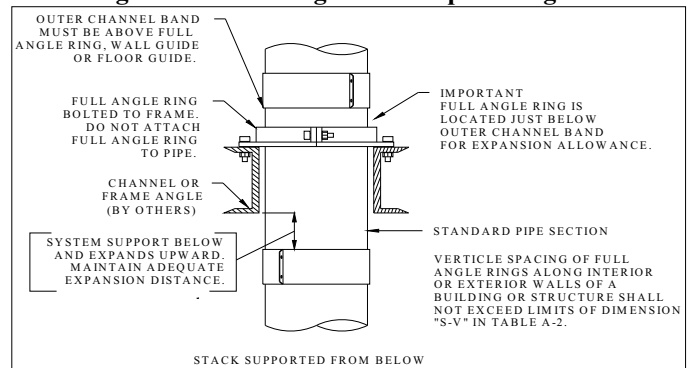
**FLOOR GUIDE (P-FG)**

The Floor Guide comprises a Full Ring, two long angles, and two flat straps, and is used where the system can be braced within a floor opening. As shown in the plan view, the flat straps provide bracing to prevent sideways bending of the long angles.

**Fig. D-9: Floor Guide (P-FG)**



**Fig. D-10: Full Ring used as expansion guide**



Insulation Thickness/Size	Maximum Floor Opening
VSI & IVSI-C1	Pipe Size + 10"
IVSI-C2	Pipe Size + 12"
IVSI-Z3	Pipe Size + 14"
IVSI-C4	Pipe Size + 16"

**FULL ANGLE RING (P-FR)**

The Full Angle Ring may also be used as an expansion guide by attachment to a suitable structural steel frame. For a support cradle for horizontal run, half ring or Support Straps may be suspended by rods.

**IMPORTANT CAUTION:** The Supports and Guides described here are only suitable for attachment to noncombustible construction.

**MAINTENANCE OF STRUCTURAL STEEL USED OUTDOORS:** IT IS RECOMMENDED TO APPLY AN EXTERIOR GRADE HIGH HEAT PAINT TO ANY PLATE SUPPORTS, FULL/HALF ANGLE RINGS, WALL SUPPORTS/GUIDES, EXPOSED OUTDOORS TO ENSURE MAXIMUM CORROSION RESISTANCE. (Ex. Rustoleum V2100 series High Heat Industrial Aerosol)

### Roof and Wall Penetration

#### ROOF SUPPORT ASSEMBLY (P-MRS)

The Roof Support Assembly is primarily for penetration of roofs of combustible construction. It can be installed with wood framing at two inch minimum clearance to the Thimble structural shield (see Fig. E-2 & Fig. E-4).

Nominal framing dimensions are given in Table E-1 (see also Fig. E-1). For pitched roofs it is necessary to construct a level curb suitable for attachment of the support brackets.

The vertical length of this assembly allows penetration of roof structure up to 8 inches deep.

Air circulation through the Roof Support should not be blocked off if the chimney is being used for high temperature applications (1,000°F and above) and is installed through combustible roof structure. In small boiler rooms with gravity air supply, it may also serve as a ventilation air outlet.

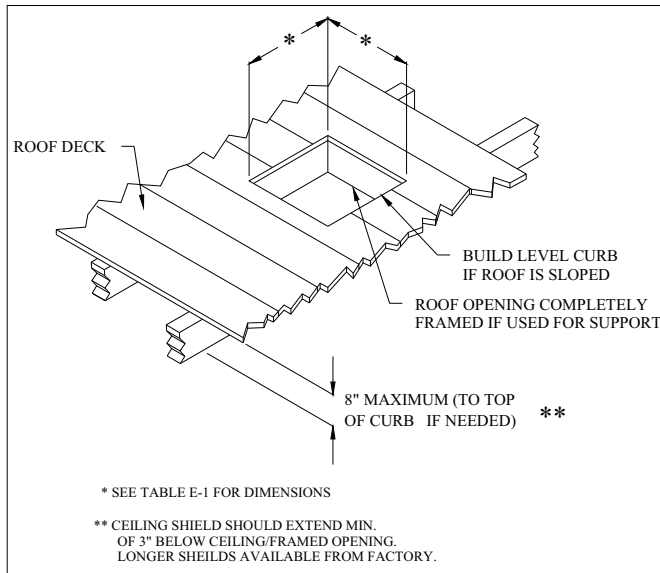
See Table A-3 for Roof Support Capacities.

Use of a Full Angle Ring or a Wall or Floor Guide Assembly is recommended, just below the Roof Support.

The Roof Support Assembly mounts directly to combustible structure using four 1/4 X 2 1/2 inch lag screws in each support bracket. The holes for the lag bolt at the bottom of the brackets may not be factory predrilled and will require to be done in the field. The VSI/IVSI pipe from below and the next pipe section above are attached to the Roof Support using the Clamp Flange provided (Fig E-2). The Flashing is then centered over the opening. The Storm Collar is placed on the pipe and in contact with the Flashing. Use silicone sealant at the joint between pipe and collar.

The ceiling shield is then attached to the support body using the fasteners provided.

**Fig. E-1: Framing dimensions for Thimble and Roof Support Assembly. (P-MVT & P-MRS)**



#### VENTILATED ROOF THIMBLE (P-MVT)

The Ventilated Roof Thimble, which does not include a pipe section, is primarily for penetration of building roofs of combustible construction. It can be installed with wood framing at two inch minimum clearance to the Thimble structural shield (see Fig. E-3 & E-5). It may be used with all types of roofs.

Nominal framing dimensions are given in Table E-1 and shown in Fig. E-1. For pitched roofs, it is necessary to construct a level curb.

The Thimble mounts directly to a level combustible structure using four 1/4 X 2 1/2 inch lag screws in each external bracket. Pipe is assembled from below and inserted up through the Full Ring provided with the Ventilated Thimble. The Flashing is then centered over the framed opening. The Storm Collar is placed on the pipe and in contact with the Flashing. Use silicone sealant at the joint between pipe and collar.

The Storm Collar has internal spacers, and when placed over the pipe will rest on the Flashing to maintain clearance for the ventilation air exit. The ceiling shield is then attached to the thimble body using the fasteners provided.

This Thimble includes a Full Ring (Part No. P-FR) which provides lateral chimney support to resist outdoor wind loads; follow the "F" dimension shown in Section A for maximum free standing heights above the Full Ring which is secured to the Thimble body.

For the Ventilated Roof Thimble (as with the Roof Support) do not block off air circulation through the Thimble if the stack is installed through combustible roof structure.

When installing VSI pipe through the Thimble, be certain there is adequate vertical expansion allowance between pipe Outer Channel bands and the Full Ring supplied with the Ventilated Thimble. If an Outer Channel Band is directly below this Full Ring, on upward expansion, the Ring may distort or damage the tabs on the assembled Channel Bands.

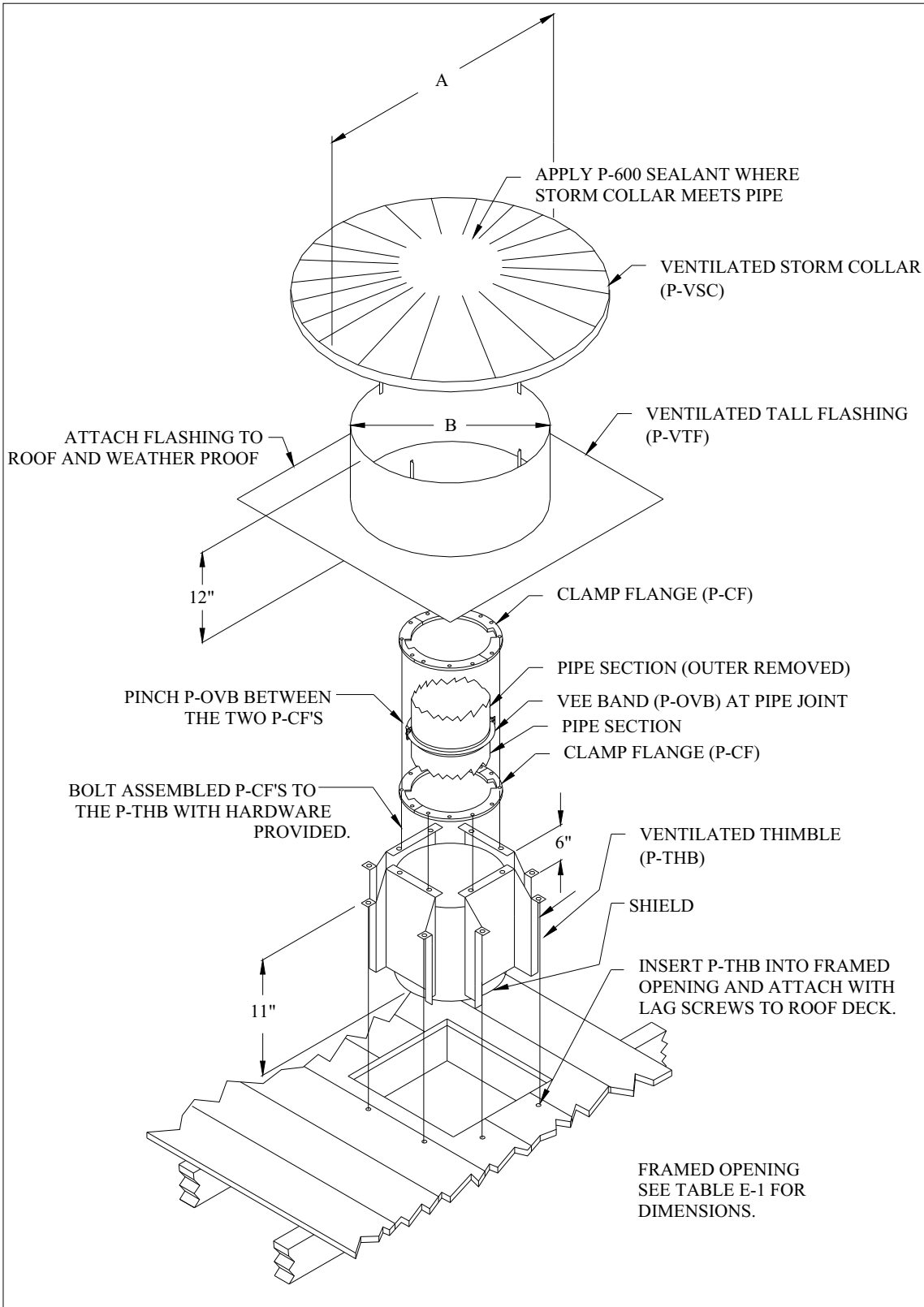
**Table E-1: Roof Support and Ventilated Thimble Dimensions (P-MRS & P-MVT)**

Wall Thickness /Designation	Framing Dimension	Collar Diameter Dim 'A'	Flashing Diameter Dim 'B'
1"/VSI & IVSI-C1	Pipe Size + 8"	Pipe Size +20.5"	Pipe Size +14.5"
2"/IVSI-C2	Pipe Size + 10"	Pipe Size + 22.5"	Pipe Size +16.5"
3"/IVSI-Z3	Pipe Size + 12"	Pipe Size + 24.5"	Pipe Size +18.5"
4"/IVSI-C4	Pipe Size + 14"	Pipe Size + 26.5"	Pipe Size +20.5"

\*See Figs. E-2 through E-5.

**EXTERIOR CORROSION PROTECTION:** IT IS RECOMMENDED TO APPLY AN EXTERIOR GRADE HIGH HEAT PAINT TO ANY ALUMINIZED OUTER WALLS & ROOF/WALL FLASHING COMPONENTS, EXPOSED OUTDOORS TO ENSURE MAXIMUM CORROSION PROTECTION AGAINST THE ELEMENTS. (Ex. Rustoleum V2100 series High Heat Industrial Aerosol)

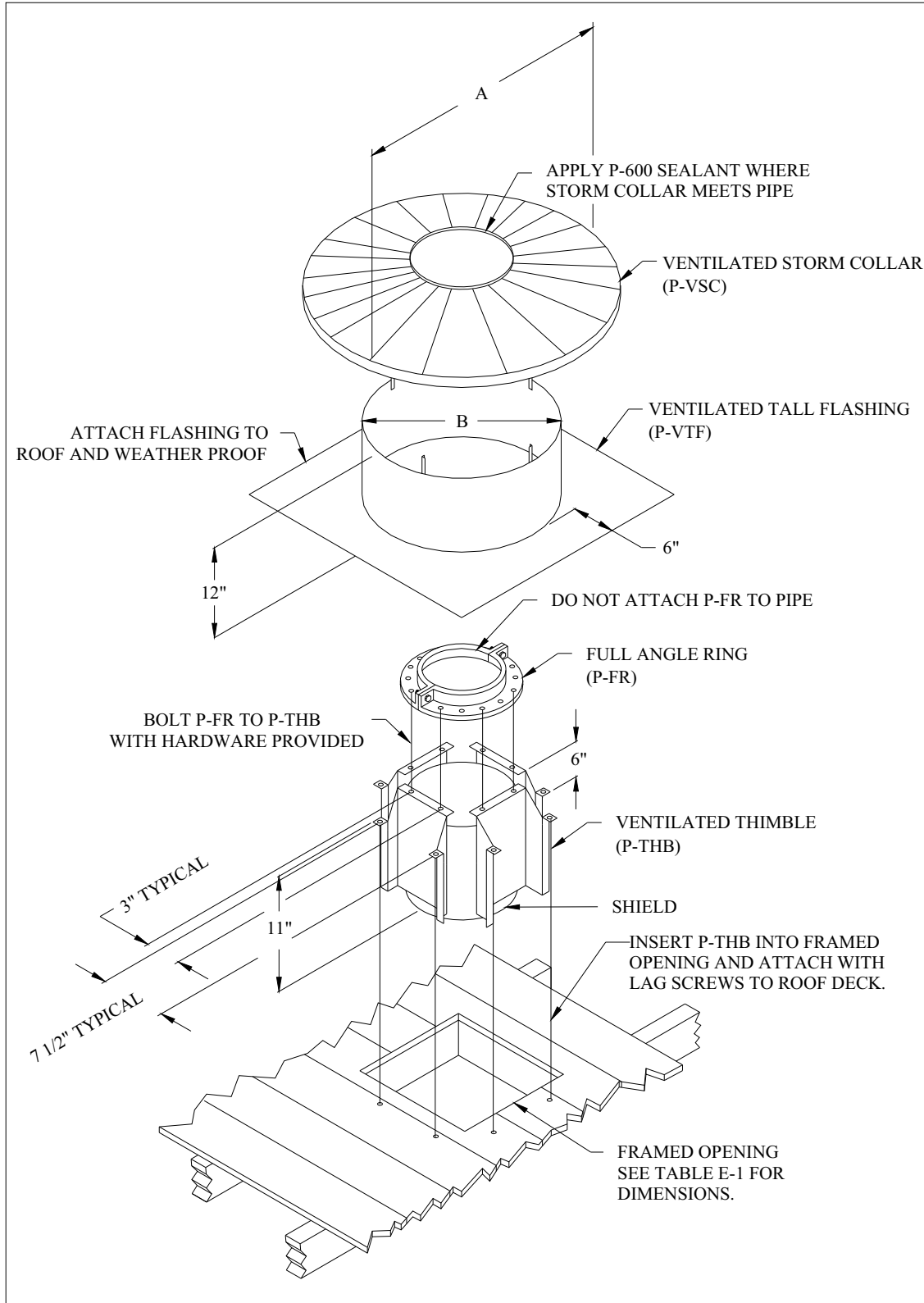
**Fig. E-2 - Roof Support Installation (P-MRS)**



**NOTE:** SEE TABLE E-1 FOR A, B AND FRAMING DIMENSIONS. SHIELD SHOULD EXTEND MIN. 3" BELOW CEILING/FRAMED OPENING. LONGER SHIELDS ARE AVAILABLE FROM THE FACTORY.

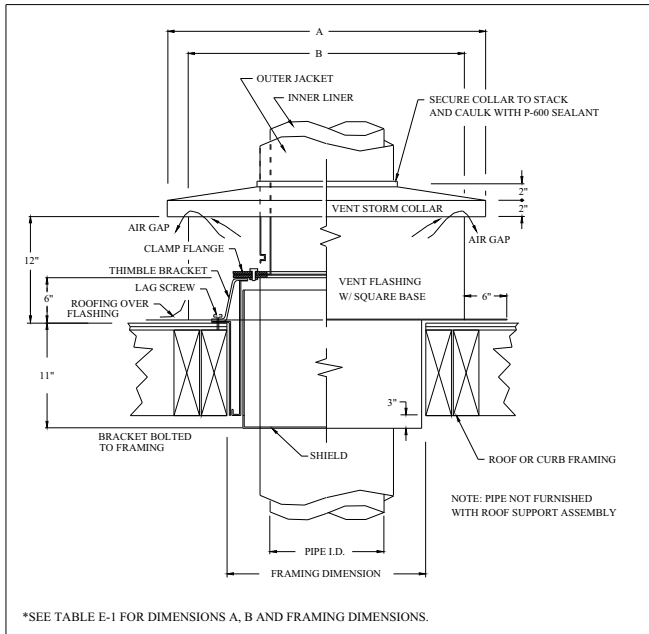


**Fig. E-3 - Installation of Ventilated Roof Thimble (P-MVT)**

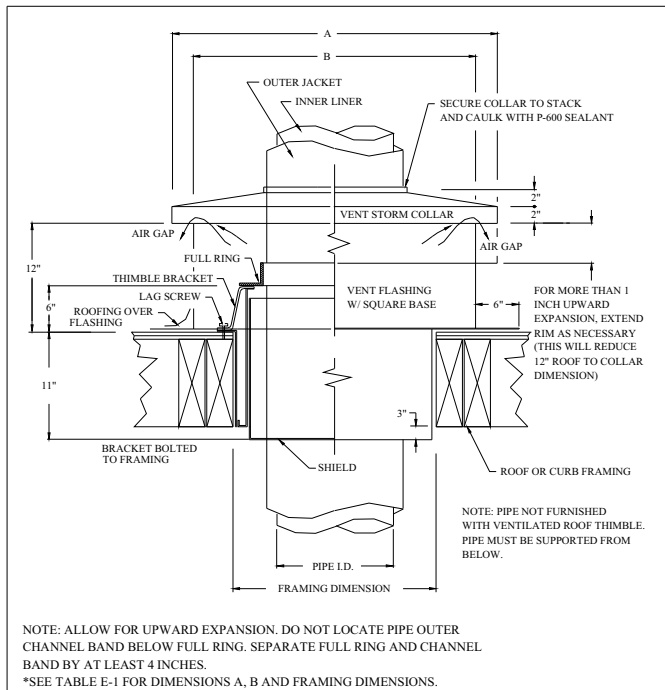


**NOTE:** SEE TABLE E-1 FOR A, B AND FRAMING DIMENSIONS. SHIELD SHOULD EXTEND MIN. 3" BELOW CEILING/FRAMED OPENING. LONGER SHIELDS ARE AVAILABLE FROM THE FACTORY.

**Fig. E-4 – Roof Support Installation (P-MRS)**



**Fig. E-5 – Installation of Ventilated Roof Thimble (P-MVT)**



**FLASHINGS AND STORM COLLARS (P-TF AND P-SC)**

The Flashing Assembly consists of a square base Tall Cone Flat Roof Flashing, plus a Storm Collar counter flashing. Both of these fit the outside diameter of Model VSI/IVSI pipe. These parts are made of galvanized steel, which should be cleaned and painted after installation to help resist corrosion. These parts are optionally available in stainless steel for ease of maintenance.

This nonventilated Flashing is for use only on completely noncombustible, flat or slightly pitched roofs. The

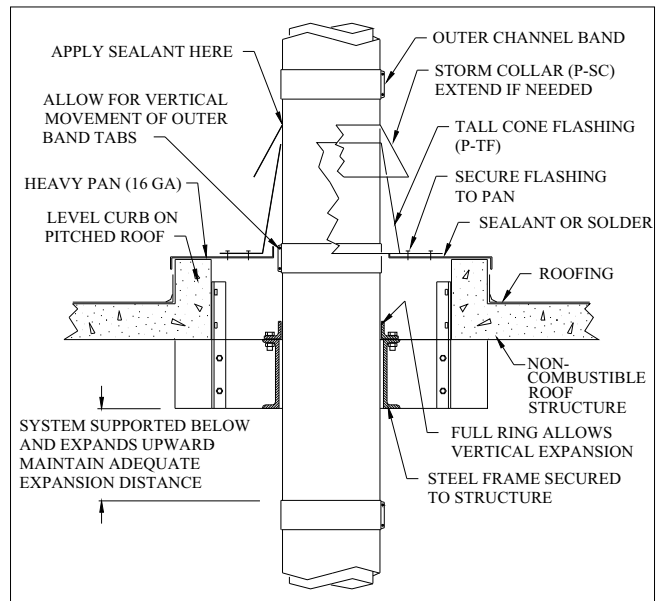
Flashing is not intended to take any side load or wind loads, thus a Full Angle Ring below the roof is used for lateral stability. For heights above the angle ring exceeding the Dimension F freestanding limit, external guiding or guying is required to stabilize against wind loads.

To allow for thermal expansion upward through the Flashing, the first outer band below the Flashing must be down far enough to avoid interference. Further, if more than 5 inches of expansion is expected, the Storm Collar should be extended downward with an added ring of galvanized steel.

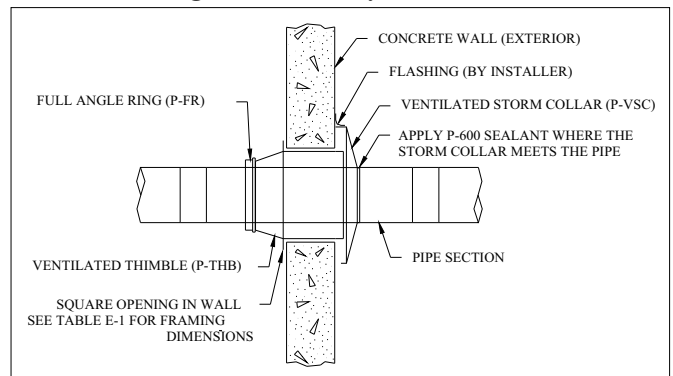
For maximum height above the roof, use a Plate Support Assembly (P-PA) just below the roof with appropriate guying or bracing above the roof.

The Storm Collar mounts on the pipe immediately above the Flashing. The joint between Storm Collar and pipe should be sealed with silicone sealant.

**Fig. E-6 - Installation of Tall Cone Flashing (P-TF)**



**Fig. E-7 - Masonry Wall Detail**



**OTHER PENETRATIONS**

In many engine exhaust and other applications, Model IVSI may pass through an exterior masonry wall horizontally. Fig. E-7 shows a simple solution which can be easily incorporated.

**GENERAL**

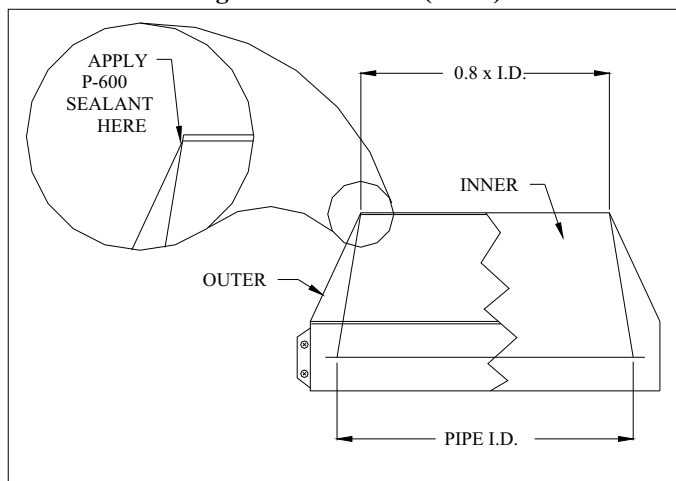
An upward discharge (such as with an Exit Cone or Open Top) provides the most effective means of dispersing chimney gases into the atmosphere and away from immediate surroundings. Such terminations however, will allow entry of rain unless there is upward flow at high velocity. A Stack Cap is only partially effective in excluding rain. Its effectiveness depends on chimney gas flow rate, raindrop characteristics and wind velocity.

With all VSI/IVSI Chimney terminations, where rain may enter the chimney outlet, the following precautions must be taken:

1. All inner joints must be sealed with sealant.
2. Install a Drain Section at least 5 pipe diameters below the chimney outlet, but above any Tee or Elbow.
3. If a 90° or 45° Tee is used to catch rain, connect the Tee Cap drain fitting to a suitable drain. Use a trap in the drain if the system is under positive pressure.

Note: The Drain Section and Tee Cap drain may both be used.

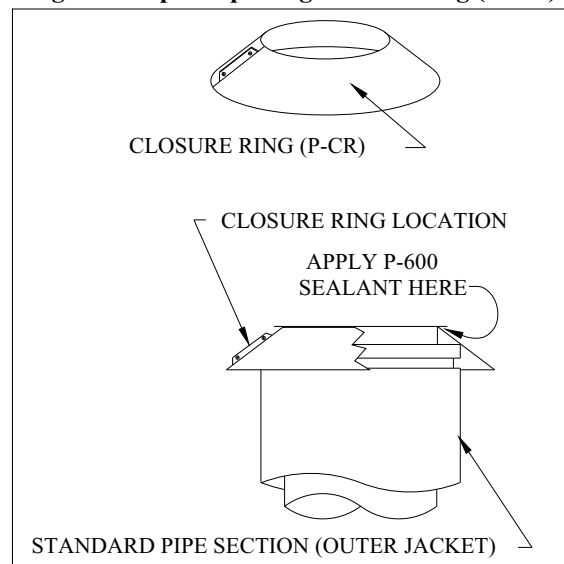
**Fig. F-1 - Exit Cone (P-EC)**



**EXIT CONE (P-EC)**

The Exit Cone is of double wall construction, with separable inner and outer cones. The inner cone has a 28° included cone angle and is sized to increase outlet velocity to 1.5 times chimney velocity. It attaches with a standard Inner Vee Band to the uppermost chimney pipe section. The outer cone is then pushed down into contact with the inner cone, clamped to the outer pipe, and the gap between cones is sealed with silicone. To prevent rain from reaching an appliance, this installation requires use of a Drain Section (DS), drained Tee or both in the vertical chimney.

**Fig. F-2 - Open top using Closure Ring (P-CR)**



**OPEN TOP USING CLOSURE RING (P-CR)**

A vertical Model VSI/IVSI Chimney can be terminated above the roof with a standard pipe length using a Closure Ring (CR) provided that rain entering is collected and drained from a Tee at the base of the vertical, or by a Drain Section located indoors at least 5 pipe diameters down from the chimney outlet. The Closure Ring fits under the flanged end of the pipe and provides protection against rain entering the space between inner and outer jackets. The Ring is secured by means of screws through end tabs. It should be sealed with sealant underneath the flange and at closure tab area.

**STACK CAP (P-SK)**

NOTE: Stack Caps are not recommended for use with engine or turbine exhausts.

The Stack Cap combines partial protection against rain entry with low exit flow resistance. (Resistance coefficient is roughly 0.05 velocity heads.) It is mounted to the end of a standard pipe section by use of the standard Vee Band. A Closure Ring is provided as part of the Stack Cap so that the insulating air space is maintained through the upper end of the chimney. A Closure Ring should be installed as described above. See Fig. F-3.

**REMOVAL OF TERMINATION CAP FOR INSPECTION & CLEANING**

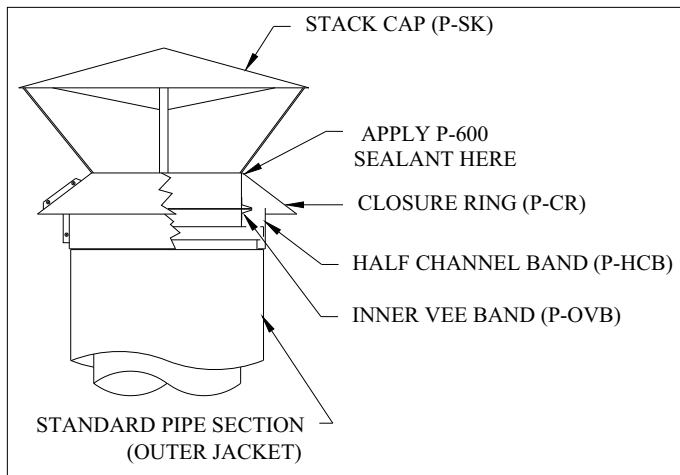
Termination Caps can be removed for inspection and cleaning of the chimney system. To remove termination, reverse the order of installation procedure. See sections corresponding to the termination cap and Pipe Joint Assembly.

**DRAIN SECTION (P-DS)**

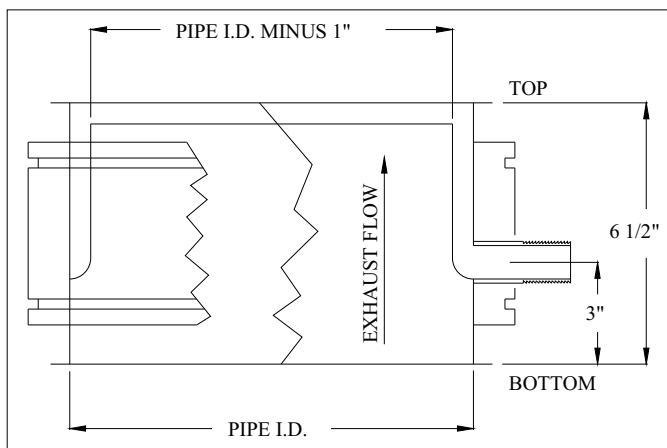
The Drain Section is a short length of inner pipe having an internally welded rain collection ring. As indicated in the cross sectional drawing (Fig. F-4), rain entering the chimney and running down the pipe wall will be collected and piped down into a trap, jar, or shallow sump. A distance of at least 5 diameters of pipe (more improves performance) should be used between the Drain Section and the chimney outlet to assure effective operation.

It is recommended to install the Drain Section indoors in a vertical chimney, thus avoiding freeze-ups. It eliminates the problems inherent in the use of air gap, above-the-roof types of stack drains by minimizing gas cooling and blow back problems. It can be used in conjunction with a Stack Cap or an Exit Cone for even greater effectiveness. Flow resistance of the rain collection ring is 0.25 velocity heads. The drain line should be run to a water seal or trap located below the top of the Drain Section gutter to prevent internal overflow due to back pressure. \*If it must be used outdoors, then the gap between the hole in the outer wall and the drain port protrusion must be sealed w/ silicone.

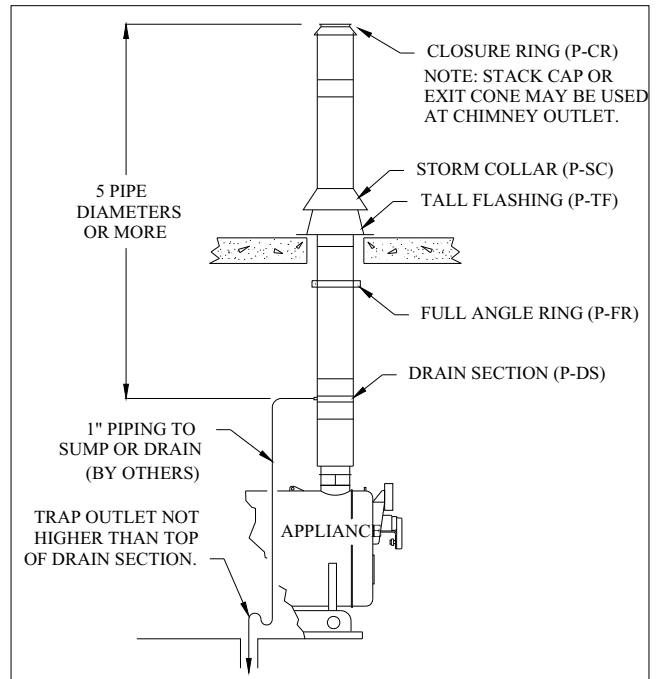
**Fig. F-3 - Installation of Stack Cap (P-SK)**



**Fig. F-4 - Construction of Drain Section**



**Fig. F-5 - Installation required for Drain Section (P-DS)**



**TERMINATION HEIGHT**

A minimum chimney height of 8 feet above the roof it penetrates or above all nearby flat roof, wall or deck is recommended for any VSI/IVSI Chimney terminations. This will help disperse exhaust gases away from the building, and will minimize contamination of nearby air intakes. Gases will be discharged above working and breathing level and there will be little chance of debris being dropped into the chimney. The additional height will also improve the effectiveness of a Drain Section.

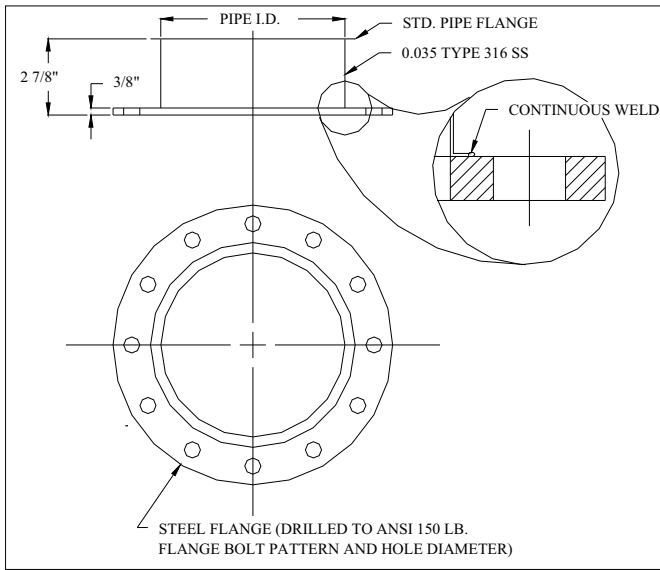
Regardless of the foregoing recommendation, height of a chimney should meet the following requirements.

- a) Proper height for the category of appliance to which it is connected. (See NFPA 211.)
- b) Adequate for the draft needs of the appliance.
- c) Complies with applicable building or fire codes.
- d) Complies with applicable air pollution regulations for height and velocity.

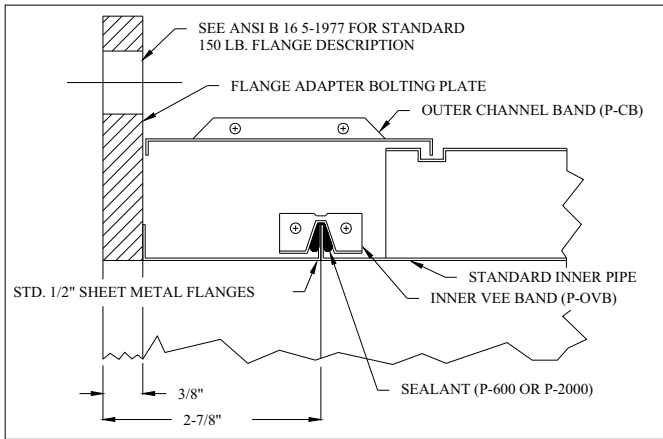
**FLANGE ADAPTER (P-FD)**

Attachment of a Bellows Joint to the silencer outlet or any flanged connection uses the Flange Adapter. It has a 3/8" thick steel flange with appropriate 150 lb. ANSI bolt pattern. An outer band is furnished to cover the air space around this adapter. (See Fig. F-6 for the actual configuration of the Flange Adapter and Fig. F-7 for an illustration of an assembled unit.)

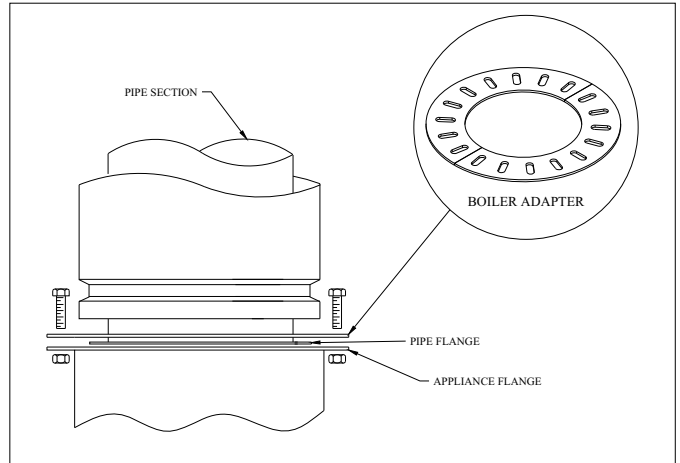
**Fig. F-6 - Flange Adapter (P-FD)**



**Fig. F-7 - Assembled Flange Adapter**



**Fig. F-8 Boiler Kit Adapter**



**SEAL RING (P-SR)**

The Seal Ring is designed to seal the VSI/IVSI flanged inner wall to an appliance equipped with an unflanged outlet collar. The Seal Ring collar has a joint that allows the diameter of the collar to adjusted and tightened down on an adjoining collar (See Fig F-9).

Note: The P-SR does not provide any load bearing support and must be isolated from loads and expansion forces. This is done by installing a support assembly above (vertical runs) or beside (horizontal runs) the P-SR. Refer to Support Section for details.

To Install:

1. Loosen the hardware on the side of the P-SR collar.
2. Slide the SR over the adjoining pipe segment. The P-SR must engage a minimum of 2.5 inches.
3. Tighten the bolts on the P-SR collar.
4. Apply a continuous bead of sealant to the inside seam of the collar and P-SR.
5. Connect the inner wall flange of the first pipe section to the P-SR using the standard Joint Assembly Procedure.

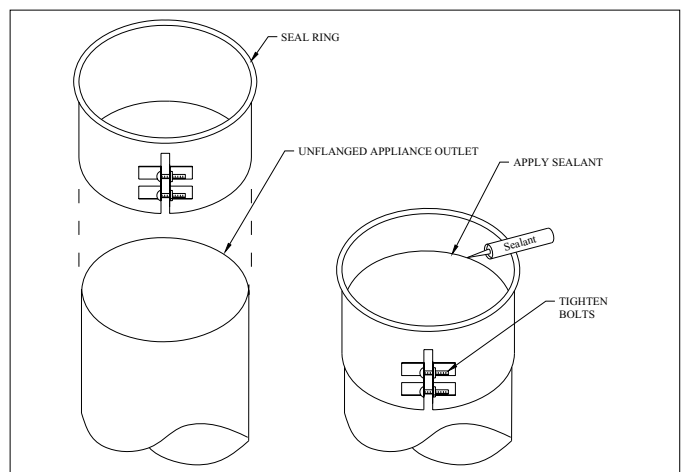
**BOILER KIT ADAPTER (P-BK)**

A Boiler Kit Adapter is designed to connect VSI/IVSI pipe to a boiler or other appliance having a flanged outlet with a 4, 6, 8 or 12 bolt hole pattern. The Boiler Adapter is a flat 1/4" thick steel ring supplied in two half-circle pieces with twenty four 3/8" x 1" slots equally spaced around the face of the adapter (See Fig. F-8).

To Install:

1. Apply a continuous bead of sealant to the face of the pipe flange and to the appliance flange.
2. Align the pipe flange with the appliance and position one half of the Boiler Adapter ring over the pipe's inner wall flange, aligning the bolt slots in the P-BK with bolt holes in the appliance and secure ring with bolts.
3. Install second half of the ring as described in step 2.
4. Tighten all nuts and bolts in an alternating pattern until the pipe flange is seated firmly between the appliance and the adapter.

**Fig. F-9 – Seal Ring**



## EXCESSIVE PRESSURE RELIEF VALVE (P-ER)

Excessive Pressure Relief Valves are intended to help control the venting of pressure which may occur during an exhaust system backfire. Engines have the potential to inject unburned fuel into an exhaust system during start up or due to an engine malfunction.

This unburned fuel creates a condition where a backfire could occur. The Explosion Relief Valve will help prevent damage to other parts such as Flex Connectors, Silencers, Catalytic Converters, Convoluted Bellows and Heat Recovery Equipment.

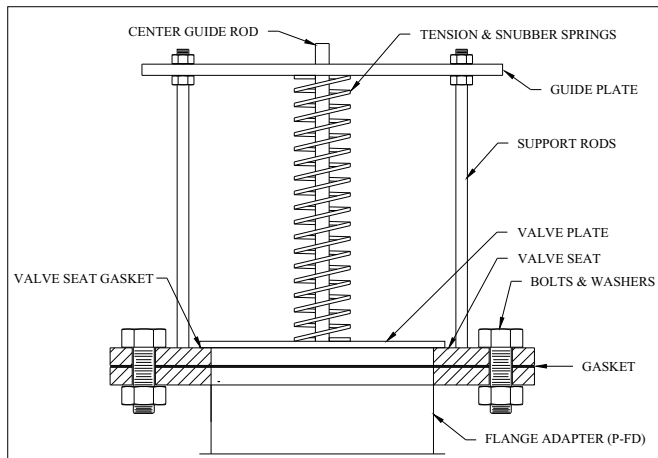
Further precedence for use of Excessive Pressure Relief Valves can be found in NFPA 37, "Standards for the Installation and Use of Stationary Combustion Engines and Gas Turbines".

The Excessive Pressure Relief Valve should be located in the system at the first change in direction (see Fig. B-7 and Fig. C-1) and is supplied with bolts, washers, nuts, and gasket to provide a complete gas tight connection to the 150 lb. ANSI flanged Flange Adapter (see Fig. F-10).

**Caution:** This device is designed to relieve excessive pressure in the case of an engine malfunction for the sole purpose of protecting the physical integrity of the exhaust system and related parts. If such malfunction occurs, the device will release hot gases, sparks and/or flames into the immediate vicinity of the P-ER.

As such, this device should never be installed where human contact with any such release is possible, or near any flammable or combustible materials.

**Fig. F-10 - Excessive Pressure Relief Valve (P-ER)**



**GREASE DUCT**

**INSTRUCTIONS AND SAFETY STANDARDS**

**Listings:**

Ampco Model N, VSI, IVSI and Z-Clear (ZC) Grease Ducts are Listed (safety certified) by Underwriters Laboratories, Inc. (UL) in accordance with UL1978, the “Standard for Grease Ducts”. They are intended to be installed in accordance with the following installation instructions and NFPA 96, the (National Fire Protection Association) “Standard for Ventilation Control and Fire Protection of Commercial Cooking Operations”.

Ampco Model Z-Clear IVSI-Z3 (Also known as ZC or Z3) and Z-Clear Plus IVSI-Z4 (Also known as ZC+ or Z4) Grease Duct Systems are Listed with a minimum zero inch clearance to combustibles. Ampco Models N, VSI and IVSI grease duct systems are Listed for use at certain minimum airspace clearance to combustibles, as identified on the labels and in these instructions.

**Classifications:**

Ampco Model Z-Clear (IVSI-Z3/ZC) and Z-Clear Plus (IVSI-Z4/ZC+) Grease Ducts are also Classified by UL in accordance with UL2221, the “Standard for Fire Tests for Fire Resistant Grease Duct Enclosure Assemblies” and ASTM-E2336, the “Test Methods for Fire Resistive Grease Duct Enclosures”. Z-Clear (ZC/Z3) is Classified for a maximum 2 hour fire resistance rating per UL2221 and a maximum 1 hour fire resistance rating per E2336. Z-Clear Plus (Z4/ZC+) is Classified for a maximum 2 hour fire resistance rating per ASTM-E2336. These ratings qualify the insulation and the outer wall of the Z-Clear (ZC) products as an alternate to the specified hourly rated fire resistive shaft enclosures (therefore eliminating the need for a separate fire resistive enclosure) and for installation at zero clearance to combustibles. See Table G-1.

<b>Table G-1 – Grease Duct Certifications</b>			
<b>Model</b>	<b>Certification Per UL1978</b>	<b>Certification/ Fire Rating Per UL2221</b>	<b>Certification / Fire Rating per ASTM-E2336</b>
N, VSI, IVSI	Yes	No	No
IVSI-Z3/ZC	Yes	Yes: 2 Hour	Yes: 1 Hour
IVSI-Z4/ZC+	Yes	Yes: 2 Hour	Yes: 2 Hour

Model N, VSI, IVSI, Z3 and Z4, Grease Duct Systems are based on the same construction. While Model VSI employs a 1" insulating airspace between walls, Model IVSI incorporates a 1", 2" or 4" of fiber insulation between walls and Model ZC (IVSI-Z3) incorporates 3" of special fiber insulation between walls. Model ZC+ (IVSI-Z4) incorporates 4" of special fiber insulation between walls. Component assembly is basically the same for each system. Model N is a single wall system, composed of the inner liner of Model VSI, IVSI, Z3 and Z4.

**APPLICATION**

Model N, VSI, IVSI, Z3 and Z4 are suitable for use in installations using exhaust system components for the removal of smoke and grease-laden vapors from commercial, industrial, institutional and similar type applications. Model N, VSI, IVSI, Z3 and Z4 Grease Ducts are intended for use as complete systems. They connect the hood or grease extractor system to the outdoors through an exhauster or blower system.

Round Ampco Grease Ducts provide for efficient airflow (lower friction loss compared to rectangular or square ducting) and superior structural integrity achieved using lighter gauge stainless steel material and fewer reinforcing members. These systems are completely integrated for a very efficient mechanical design and have the additional benefit of providing a very clean appearance on final assembly.

System installation specifications are as described in the NFPA96 and these grease ducts are to be installed to conform to that standard or as described in these installation instructions. (Grease duct systems are not to be interconnected with any other building ventilating or exhaust system.) Systems installed in accordance with these instructions comply with NFPA96, the International Mechanical Code (IMC), Uniform Mechanical Code (UMC) and other codes.

Round Ampco Grease Ducts are permitted to be installed in accordance with the clearances shown in Table G-2. Some special provisions for Grease Ducts are necessary and, in particular, cleanout openings must be provided. Cleanout openings should: 1) be provided at each change in direction of grease ducts, unless the entire length of duct can be inspected and cleaned from either the hood or discharge end or from both ends, 2) be at the sides of the duct, and 3) have the lower edge of the opening at least 1/2 above from the bottom of the duct.

System size and capacity information can be obtained from: 1) A chapter in the “ASHRAE Handbook” series entitled “Chimneys, Gas Vent and Fireplaces”, or 2) Chapter 3, “Air Pollution Engineering Manual of the U.S. Environmental Protection Agency” 1973. Refer to Ampco Model VSI, IVSI, ZC Product Catalog for descriptions of all necessary parts.

**INTERMIXING OF SYSTEM PARTS**

Model N, VSI, IVSI, Z3 and Z4 may be intermixed within a system, assuming proper clearances are maintained for the respective components. When penetrating a roof, Model VSI, IVSI, Z3 or Z4 duct sections and appropriate roof penetration components must be used. Do not use Model N sections to penetrate the roof.

**SURROUNDINGS**

Ampco Models N, VSI and IVSI are primarily intended to be used in noncombustible surroundings. Models Z3 and Z4 can be used for either combustible or noncombustible surroundings.

Where the ducting is installed in an open room and does not require an enclosure it must have a minimum clearance to adjacent combustible walls as shown in the section titled "Clearances". The ducting may be located in corners formed by two combustible walls under the above condition.

Interior installations in all buildings should be installed as follows:

- 1) If a ceiling or wall has a fire resistance rating and is penetrated by a Models N, VSI, or IVSI Grease Duct, then the duct shall be enclosed with a continuous enclosure extending from the penetration, through any concealed spaces, to or through the roof so as to maintain the integrity of the fire separations required by the applicable building code. NOTE: If penetrated by Z3 or Z4 no additional enclosure is required however the appropriate Through Penetration Firestop (TPF) must be used. See Through Penetration Section.
- 2) If a ceiling or wall does not have a fire resistance rating and is penetrated by a Model N, VSI or IVSI Grease Duct installed at the correct minimum clearance for unenclosed duct, then no enclosure is required.
- 3) Where the Model N, VSI and IVSI ducting extends through any story of a building above that in which the connected appliances are located, it must be enclosed in the upper stories with walls having a fire resistance rating of not less than one hour for buildings of two or three stories in height. If the building is four stories or more in height, the enclosure wall shall have a fire resistance rating of not less than two hours.

NOTE: Based on its qualifications model Z-Clear (Z3 and Z4) may be used in place of a separate fire rated enclosure in situations where fire rated enclosures would normally be required.

**CLEARANCES**

<b>Table G-2: Minimum Airspace Clearance to Combustibles for Grease Duct</b>						
<b>Pipe ID</b>	<b>Model VSI</b>	<b>Model IVSI-C1</b>	<b>Model IVSI-C2</b>	<b>Model IVSI-C4</b>	<b>Model Z3 &amp; Z4</b>	<b>Model N</b>
5"	5"	2"	1"	1"	0"	18" Or Per Local Code For single Wall construction Per NFPA 96
6"	5"	2"	1"	1"	0"	
8"	5"	3"	1"	1"	0"	
10"	5"	3"	1"	1"	0"	
12"	6"	3"	1"	1"	0"	
14"	7"	3"	1"	1"	0"	
16"	8"	3"	1"	1"	0"	
18"	9"	4"	2"	2"	0"	
20"	10"	4"	2"	2"	0"	
22"	11"	4"	3"	3"	0"	
24"	11"	4"	3"	3"	0"	
26"	12"	5"	4"	4"	0"	
28"	12"	5"	4"	4"	0"	
30"	13"	5"	4"	4"	0"	
32"	13"	5"	4"	4"	0"	
36"	14"	6"	5"	5"	0"	
42"	16"	7"	6"	6"	N/A	
48"	17"	7"	6"	6"	N/A	

**For noncombustible construction maintain clearances as required for installation, access for inspection, or per local code.**

Combustible roofs may be penetrated by using either the Roof Support Assembly (P-MRS), Roof Support Section (RSS), the Ventilated Roof Thimble (P-MVT), Ventilated Roof Curb (See Fig. G-5) or Fan Adapter Termination (P-FAT). Vertical walls or combustible materials may be penetrated using the Wall Penetration Assembly (THB). These are the only parts intended for use with combustible construction. All other parts, such as Plate and Wall Supports, Floor and Wall Guides, are for attachment to noncombustible construction.

**SLOPE**

Based upon performance considerations associated with its Listing by Underwriters Laboratories, Inc. (UL), no specific slope is required when installing Model N, VSI, IVSI, Z3 or Z4 grease ducts in a horizontal run. While inclusion of some slope is permitted, slope is NOT mandatory. Normal system components permit a small amount of slope as the system is being installed. Many building and / or mechanical codes dictate the inclusion of some minimum slope in horizontal runs of grease duct. This is an important consideration for rectangular, welded steel systems, since pooling of grease is a risk. The N, VSI, IVSI, Z3 and Z4 cylindrical systems are exempt from this requirement.

In some areas the local code authority may insist on inclusion of 1/4 inch per foot slope. In such case, a short "Slope Transition" (P-ST) section is available. The Slope Transition includes a slight offset at one end in order to create the 1/4" per foot slope within its length. For correct installation, two Slope Transitions are generally required. Install one at each end of the horizontal run to initiate the required slope and then return to the proper inlet orientation for the vertical portions of the system.



## PIPE & FITTING JOINT ASSEMBLY

All grease ducts must be liquid tight according to NFPA 96. The following procedure can be used to assure that all joints in the installation meet that requirement. Assembly is accomplished as follows:

1. Clean all pipe flanges and Vee Band inner surfaces with an appropriate organic solvent, such as Acetone, MEK, or other commercial degreaser (Caution: Observe adequate safety measures when using).
2. Apply a thin layer of RTV P-600 silicone sealant to the face of each pipe flange (Caution: The use of any other sealant on flange surface may impair sealing effectiveness).
3. Parallel flanges are brought together immediately.
4. Joint sealant is applied to the groove of the Inner Vee Band. Use P-600 Joint Sealant.
5. Plan to locate the clamp and tightening flanges of the Vee Bands on the sides of the grease duct horizontal run to eliminate possibility of leaks.
6. As soon as possible or within 15 minutes of applying the sealant, install the Vee Band and tightly clamp it around the flanges using end clamp hardware. (Visegrip welding pliers are extremely useful for holding the Vee Bands in place while installing the end clamp tightening bolts.) NOTE: Light tapping with a hammer all around the band while tightening the end clamp bolts helps to align and pull the flanges together.
7. (For IVSI, Z3 and Z4 only), install a 4" wide strip of insulation (supplied) over the entire Vee Band, filling the space between the spacers as shown in Fig. A-2.
8. The outer channel band is then installed by inserting the edges of the band into the outer pipe grooves and drawing it closed with the screws and nuts. For exterior joints apply sealant to the joint between the Channel Band and the outer pipe (See Figs. A-2 & A-3 & Pipe Joint Assy).

NOTE: DO NOT SEAL THE CLEANOUT ACCESS COVERS. THEY MUST REMAIN FREE OF SEALANT FOR FREQUENT INSPECTION PURPOSES.

## CAUTIONS

1. The outer channel bands are designed to slide in their mating grooves. Do not attach by screws into the outer casing.
2. Do not allow screws to penetrate the inner pipe. This can cause corrosion, gas leakage or expansion failure.
3. Never use screws through the outer jacket of an adjustable length or expansion joint.

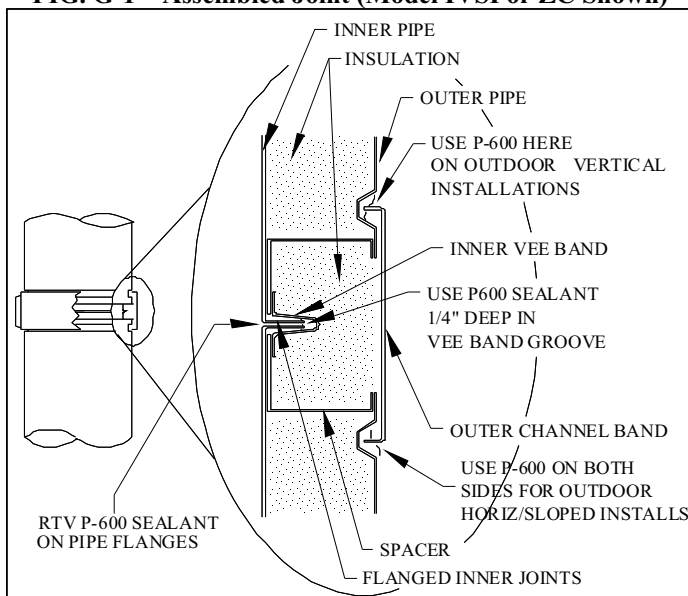
## GREASE DUCT JOINT SEALANT

Ampco Joint Sealant (P-600) is a pre-mixed, one-part, acetoxy cure silicone adhesive. Properly made joints are gas tight and highly resistant to oil, water, solvents and all acids except hydrofluoric. P600 has a "Tack-Free" time of 15 minutes at 77° F and a "Cure" time of 24 hours.

When stored in original, unopened containers below 90°F, P600 has a shelf life of 30 months from date of manufacture. After a container has been opened, a plug of cured material may form in the nozzle or tube tip during storage. Remove the cured material and the remaining sealant is ready to use.

Note: As of September 2008, Ampco P-2000 High Temperature sealant is no longer required for Grease Duct (Model N, VSI, IVSI & ZC) applications. Ampco P-600 Sealant is approved for application on both the Pipe Flanges and in the Vee-Band for Grease Duct. However, if desired, P-2000 High Temperature Sealant can be used as an alternate to P-600 in the Vee Band. In such case, P600 is still required between the flanges.

FIG. G-1 – Assembled Joint (Model IVSI or ZC Shown)



Note: Flange to flange inner pipe joints are identical except for Adjustable Lengths (P-AG) and Variable Lengths (P-VL). These require special orientation for correct use.

## MAINTENANCE AND SAFETY

The Model N, VSI, IVSI, Z3 and Z4 Grease Duct System have a special group of parts which are specifically designed to create a safe and reliable system. Those special parts include:

- Nozzle/Port Section (special part code) to integrate a fire suppression system or act as an interface for hot water/detergent maintenance section
- Grease Tee's (P-GMT) - Provide access to the duct at a 90° changes of direction for cleaning and inspection. Includes a 1" required dam to prevent liquids from spilling out when opened.
- Cleanout Doors (P-TCN) – Allows for access to the snout of a tee for inspecting and cleaning the duct.
- No-Tool Access Cap (P-NTAC) – Similar to the TCN but does not require tools to open.
- Inline Access Door (IAD) – Provides access to a straight length of grease duct for cleaning or inspection.

NFPA96 contains some very specific requirements concerning the safety features which must be incorporated into grease duct systems. This document includes guidelines to be followed related to the operation, inspection and cleaning of grease ducts and it indicates that the system shall be cleaned at frequent intervals prior to surfaces becoming heavily contaminated with grease or oily sludge. Depending on the amount of cooking equipment usage there should be a daily or weekly inspection to determine if grease or other residue has been deposited within the section. When the grease or other residues are in evidence as deposits, the entire system should be cleaned in accordance with accepted procedures. The Cleanouts and Access Components (mentioned above) are specifically designed to aid in this process and should be located at each change in direction. Long straight vertical and horizontal runs may need additional cleanouts to allow the system to be completely inspected and cleaned.

## AUTOMATIC CLEANING

An automatic hot water/detergent injection system can be integrated into the N, VSI, IVSI, Z3 and Z4 Grease Duct systems by using the dual purpose Nozzle/Port Section (which is also used for fire suppression) and Tees with nipped Base Drains. All of these related parts have standard NPT hardware so that conventional nozzles and piping can easily be attached. Please keep in mind that if plumbing is connected to cleanout inspection caps, flexible high temperature, high pressure plumbing must be provided with shutoff valves so that the inspection process can be completed on a regular basis.

A typical installation would provide hot water at approximately 160°F and use a detergent injected by conventional hardware so that the entire grease duct system can be scrubbed down daily (using jet spray characteristics) for the removal of grease, dirt and dust. Normally the automatic cleaning system is designed as a unit, however a modular design would prove satisfactory.

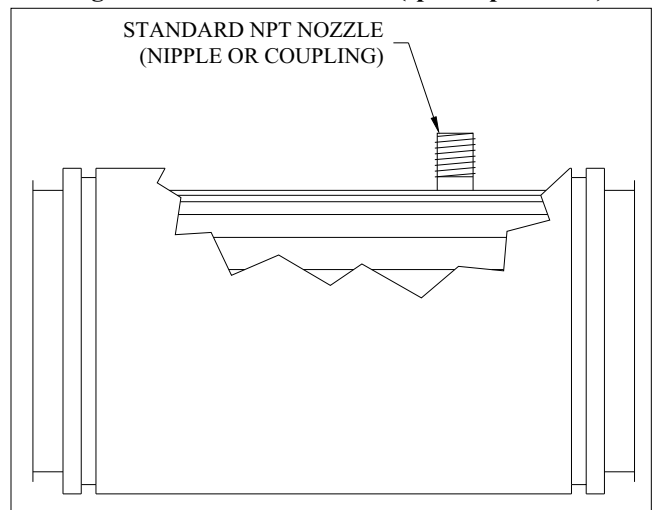
Automatic cleaning implies that the grease drains are connected to appropriate hardware so that the residues of the cleaning process are piped directly to drains and not grease traps or fixed size buckets.

## FIRE SUPPRESSION

The practice of NFPA 96 concerning fire safety requires that fire extinguishing equipment shall be provided for the protection of duct systems, grease removal devices and hoods, especially if all the cooking equipment is not served by Listed grease extractors. The use of a special Pipe Section w/ Port/Nozzle allows various types of fire extinguishing equipment to be integrated into the grease ductwork, if necessary. Some of the various types are: 1) CO2 extinguishing systems (NFPA 12), 2) Sprinkler systems (NFPA 13), 3) Foam-Water Sprinkler/Spray Systems (NFPA 16), and 4) Dry Chemical Extinguishing Systems (NFPA 17). The Nozzle Section (See Fig. G-2) can be positioned so that the nozzle fitting is either on the sides or top of the section consistent with good fire protection design practice. Various diameter NPT couplings offered allow for flexibility when making the required connections (See Fig. G-2).

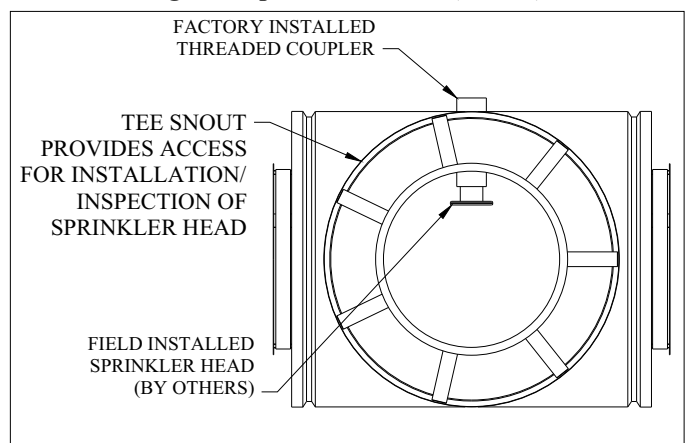
Nozzle Grease duct tee sections with sprinkler port (P-NTS) are also available for installations requiring sprinkler heads with access for inspection / cleaning. The P-NTS tee sections include a coupling to accept standard 1/2" (or 3/4") NPT sprinkler heads (See Fig. G-3).

**Fig. G-2 Nozzle/Port Section (special part code)**



Note: The access port of the tee section should be located/oriented horizontal to upward to avoid the possibility of collecting grease.

**Fig. G-3 Sprinkler Section (P-NTS)**



## HOOD TRANSITION

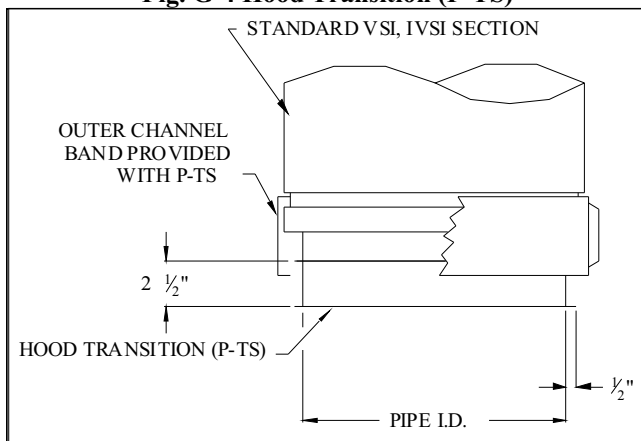
The Model N, VSI, IVSI, Z3 and Z4 Grease Duct Hood Transition (P-TS or P-TSU) Stubs are stainless steel extensions of the standard inner pipe used in normal Model N, VSI, IVSI, Z3 and Z4 Duct Sections. The P-TS is furnished as a single wall piece with 1/2 inch flanges at both ends. The P-TSU (Unflanged Hood Transition Stub) is available for those installations where the flange is needed only on one end.

The P-TS or P-TSU Stub can be welded directly to the hood or to a transition which has been fabricated to match the opening in the hood. The transition must be constructed so that it does not create a high air flow loss. A third alternative, when required, is to fabricate a special transition piece which tapers the exhaust hood port into the Model N, VSI, IVSI, Z3 and Z4 Grease Duct stack diameter so that a smooth, low loss connection occurs.

The use of Model N, VSI, IVSI, Z3 and Z4 Grease Duct Transition Stub allows many different termination methods to be considered for high quality, simple, practical installations. Provision should be made to have transition welded to hood or attached per NFPA 96 bolt on system.

When appropriate, special tapered hood transitions (rectangular to round or round to round) are produced to order. They are fabricated as a welded, stainless steel unit and may be provided with or without flanges for direct field attachment via welding. They are provided with the appropriate insulation and a two piece, "clam shell" type outer wall / protective enclosure for around the insulation.

**Fig. G-4 Hood Transition (P-TS)**



## CLEANOUT TEE CAP (P-TCN)

The Cleanout Tee Cap provides access for inspection into the grease duct. Both the inner and outer has handles for easy removal.

When using with part numbers P-MT, P-JL, and P-JY, a step Increaser (P-OS) is required to assure the cleanout opening is at least 1 inch from the bottom of the duct.

When using cleanouts, always prevent leaks and assure that the grease duct functions as intended (see Joint Assembly Procedures).

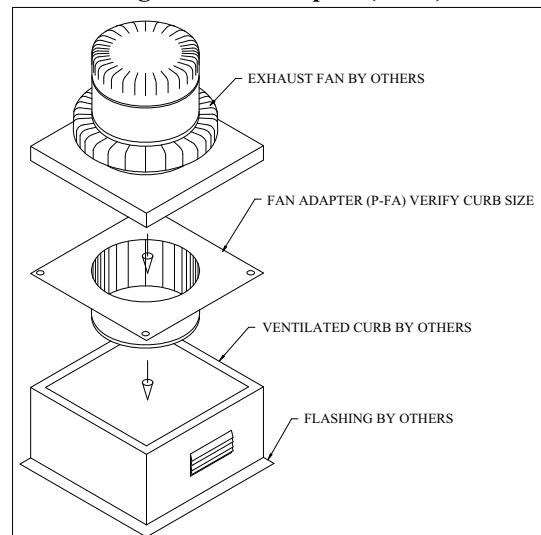
## FAN ADAPTER (P-FA)

The Fan Adapter is used, in many installations, to provide for the final connection between the grease duct system and an "upblast" fan. The adapter incorporates a square plate (on the top or outlet end) and a short section of duct incorporating a flanged end (on the bottom or inlet end). It is designed to set directly on top of the roof curb (by others) and directly beneath the fan base (by others). (See Fig. G-5)

The Fan Adapter is first attached to the roof curb using bolts or screws through the square plate and into the curb. The inlet end connects to the remainder of the grease duct system using a Vee Band and typical assembly methods described under "Pipe Fitting Joint Assembly".

A vented curb should be used if the roof construction being penetrated is of combustible construction.

**Fig. G-5 Fan Adapter (P-FA)**



## ROOF SUPPORT SECTION & FAN ADAPTER TERMINATION (RSS & FAT)

The Roof Support Section (RSS) is a section of ZC grease duct that is designed to penetrate through the roof and attaches to the roof surface, providing support for the duct system parts suspended below, or extended above the RSS.

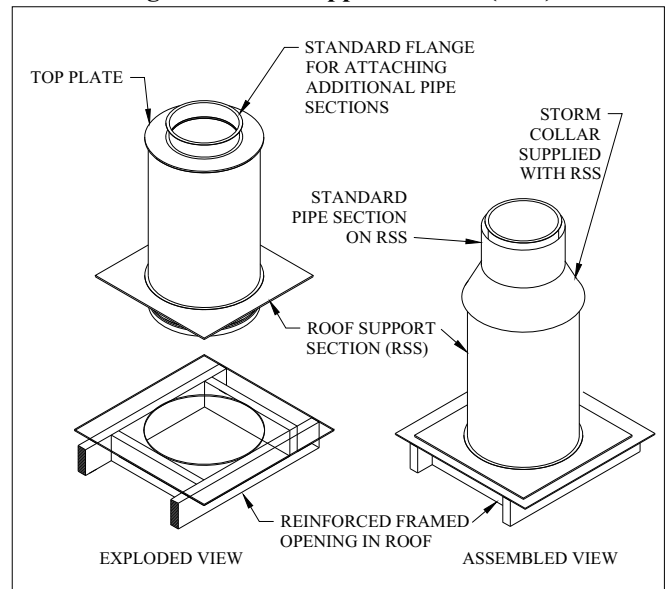
Similarly, The Fan Adapter Termination (FAT) is a section of a ZC grease duct that incorporates a fan curb and provides a surface for mounting and installing an up-blast discharge fan. The FAT eliminates the need for a separate welded fan curb termination assembly. The square curb is specifically designed to accommodate hinged type exhaust fans, commonly used for extraction of cooking fumes. The FAT also provides vertical support for the duct system and in some applications, when installed and supported properly, the weight of the hood and duct system may be suspended from the FAT.

The RSS & FAT are non-ventilated roof penetration components that are only available in model Z3 or Z4. However they can be used with other systems provided the proper clearances are maintained for the other grease duct parts.

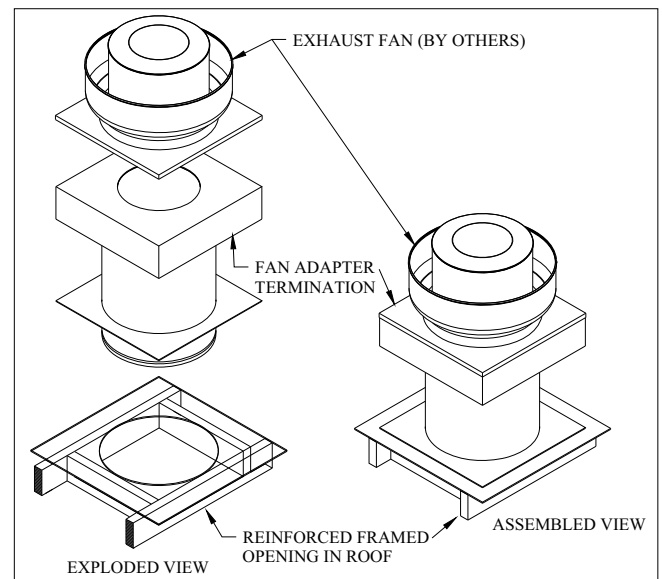
To Install:

1. Prior to installation, refer to WEIGHT OF PIPE section and hood manufacturer to determine the total combined weight of the hood and the duct system. If the total weight of the entire system exceeds the Maximum Suspended Weight specified in Table G-2, the duct system will require additional vertical support. Refer to SUPPORT METHODS section of instructions
2. Determine the total length of the Grease Duct System. If total length of duct exceeds 12 feet, an Adjustable Length (P-AG) and additional support will be required to compensate for thermal expansion. Refer to THERMAL EXPANSION section for proper installation instructions.
3. Determine the exact location where the grease duct system will penetrate the roof. Prepare an opening in the roof 1/4" larger than the diameter of the outer casing.
4. Determine if adequate support is available to bear the load of the RSS or FAT and other duct system parts. If necessary, add additional steel roof joists and bracing, creating a framework to support the load of the duct (see Figs. G-6 & G-7). Refer to Table G-2 (RSS & FAT Suspended Weight & Length Limits) and WEIGHT OF PIPE section to determine load bearing capacity and compare it to the anticipated total load to make certain the grease duct system is properly supported and that the component parts and structural members are not overloaded.
5. Once adequate support is established and any supplemental bracing / framing is fabricated, install inlet end of RSS & FAT into roof opening. Ensure that the top surface of the RSS or FAT is level, and secure roof plate to structural members of roof using the appropriate fasteners (by others).
6. Apply roofing material over roof plate to seal off any openings in the roof.
7. For the FAT, see fan instructions for proper installation of the fan assembly. For the RSS, refer to Section "A" PIPE & FITTING JOINT ASSEMBLY for instructions on attaching additional duct sections to the top of the RSS. Once sections are properly attached, install the Storm Collar (SC) included with the RSS so that it shields the top plate of the RSS (See Fig G-6).
8. Refer to instructions for installing remaining grease duct system components

**Fig. G-6. Roof Support Section (RSS)**



**Fig. G-7. Fan Adapter Termination (FAT)**



<b>Table G-2. RSS &amp; FAT Suspended Weight Limit</b>	
<b>Pipe Size</b>	<b>Max Weight Suspended from RSS &amp; FAT</b>
8" – 14"	400 Lbs.
16" – 20"	500 Lbs.

**THROUGH-PENETRATION FIRESTOP (UL SYSTEM C-AJ-7101) (TPF)**

**Through-Penetration Firestop (UL System C-AJ-7101) for Model Z-Clear and Z-Clear Plus**

Fire Resistance Rating: 2 Hour (F & T)

Whenever the Z-Clear (Z3) or Z-Clear Plus (Z4) grease duct passes through a fire rated wall or floor, a Through-Penetration Firestop Kit must be used to retain the fire rating. Use one Through-Penetration Firestop Kit for a floor penetration and two Through-Penetration Firestop Kits for a wall penetration.

**Kit Contents:**

- Closure Band (1)
- Cover Plate Half (2)
- 12" Wide Insulation Strip (1)
- 4" Wide Insulation Strip (1)

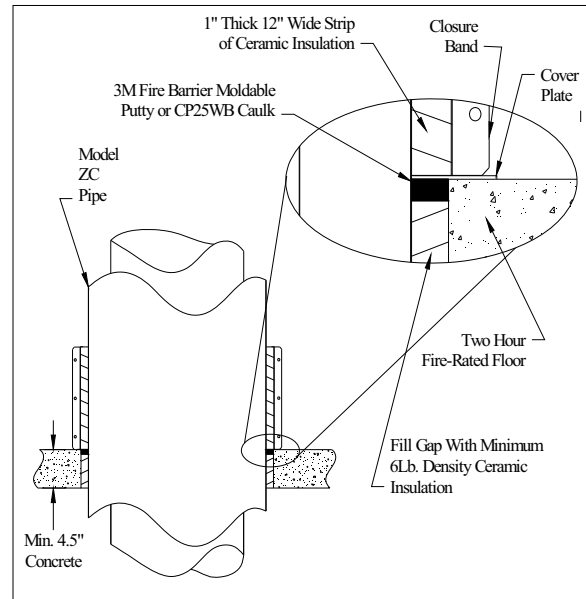
Note: Firestop Putty / Caulk Not Included

**To Install:**

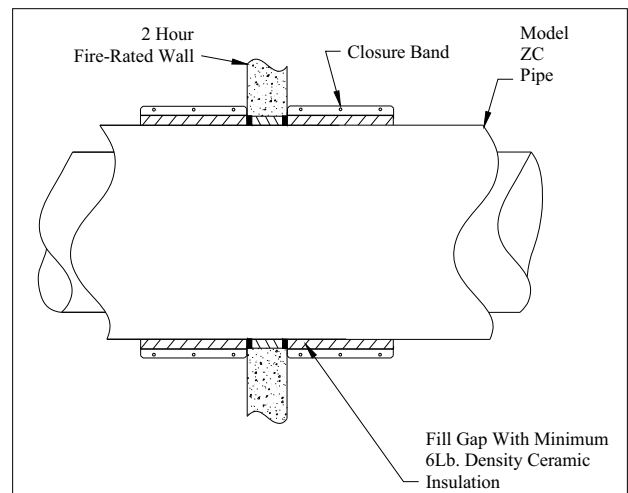
1. Cut a circular hole into the fire rated floor or wall that is 2" greater in diameter than the OD of the duct.
2. Center the Z3 or Z4 grease duct within the hole and support to maintain position.
3. Tightly pack the 1" gap between the outer wall of the duct and the hole with the 4" Wide 6 pcf ceramic fiber insulation strip provided. This insulation must encircle the outer wall of the duct and fill the gap to within 1/2" of the floor surface or to within 1/2" of both surfaces of the wall (See G-9).
4. Apply a minimum 1/2" depth of 3M Fire Barrier Moldable Putty or 3M CP25WB+ caulking, flush with the top surface of the floor or flush with both surfaces of the wall (See G-9).
5. Install the two piece rectangular Cover Plate. The two piece rectangular Cover Plate is designed to fit over the Putty or caulk and around the outer wall of the duct. There will be a nominal 1/4" gap around the pipe and the two parts of the plate must overlap each other a minimum of 1". Secure in place with appropriate hardware (See G-8 & G-10).
6. Wrap a 12" wide strip of the ceramic fiber insulation around the grease duct. The insulation must butt up to the cover plate and outer wall of the duct. Secure in place with the closure band using the hardware provided.
7. Note that cover plates, wrap insulation and closure bands are installed on the top surface of a floor penetration and on both surfaces of a wall penetration.

**Caution:** Do not use the Adjustable Length (P-AG) with the Through Penetration Firestop.

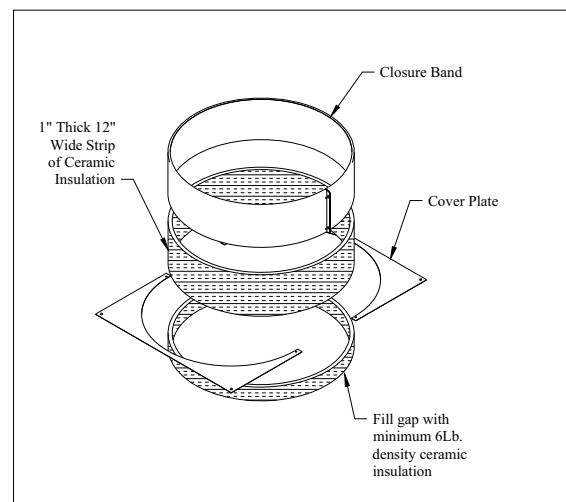
**Fig. G-8 Floor Penetration**



**Fig. G-9 Wall Penetration**



**Fig. G-10 Isometric View of Through Penetration Firestop Kit**



## NO-TOOL ACCESS CAP (P-NTAC)

The No-Tool Access Cap provides no tool access for inspection and cleaning of the grease duct. When connected to an MT, JL or JY, the NTAC functions as a no tool substitute to a 90° Grease Tee (GMT) and a standard Cleanout Tee Cap (P-TCN).

### Parts List

- 1 x NT-Cover
- 1 x NT-Cap
- 1 x NT-Dam
- 2 x 1/2 Vee-Band
- 4-11 x Wing Nuts (based on pipe diameter)
- 1 x Insulation Disc (IVSI and ZC only; Factory

### Installed)

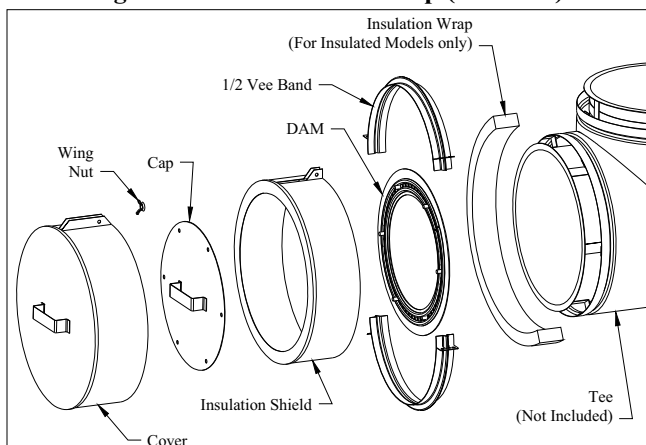
- 1 x Insulation Wrap (IVSI and ZC only)
- 1 x Insulation Shield (IVSI and ZC only)
- 1 x Hex Bolt (IVSI and ZC only)
- 1 x Hex Nut (IVSI and ZC only)

### Installation Procedure

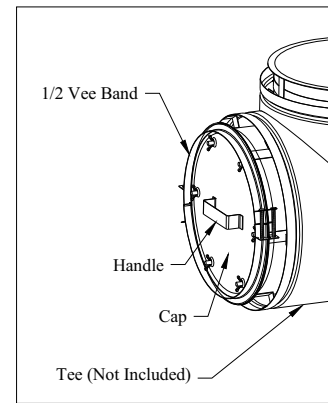
1. The No-Tool Cap is factory installed to the NT-Dam with the use of several wing nuts. Using the Vee-Band and sealant (as specified in main instructions) secure the NT-Dam and the NT-Cap to the flange of the Manifold Tee MT (not included). Be sure the handle of the NT-Cap faces outward as shown (See Fig. G-12).
2. (IVSI & ZC Models only) Insert the insulation Wrap into the cavity between the spacer clips of the tee section and the Vee-Band. Wrap insulation around the entire circumference of the assembly filling the entire cavity. Excess insulation may be trimmed and discarded (See Fig. G-13).
3. (IVSI & ZC Models only) Install the Insulation Shield over the Insulation Wrap and outer wall of the tee section, using care not to pinch the insulation in the process. Use the Hex Nut and Bolt to tighten the tabs on the Insulation Shield, securing it to the outer of the tee section. (See Fig. G-13 & G-14)
4. Slide the NT-Cover over the P-NTAC assembly. Using the Wing Nut and Bolt supplied, tighten the tabs to secure the NT-Cover to the tee section. (See Fig. G-15)

Note: The access cap of the tee section should be positioned/oriented horizontal to upward to avoid the possibility of it collecting any grease.

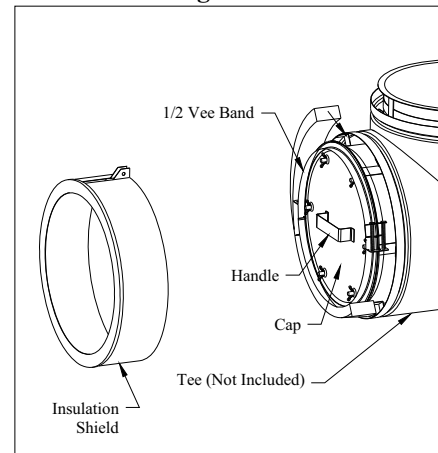
**Fig. G-11. No-Tool Access Cap (P-NTAC)**



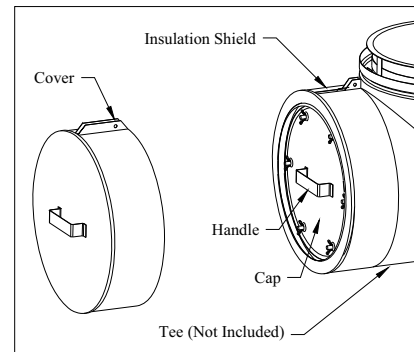
**Fig. G-12.**



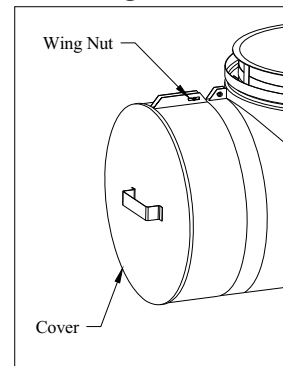
**Fig. G-13.**



**Fig. G-14.**



**Fig. G-15**



(No-Tool Access Cap Continued)

To Remove Cap for Inspection and Cleaning

1. Unscrew bolt / wing nut securing No-Tool Cover to assembly. Remove No-Tool Cover from assembly by pulling straight out. Place aside in safe place during inspection / cleaning (See Fig. G-14).
2. Unscrew wing nuts securing No-Tool Cap to No-Tool Dam. Remove No-Tool Cap from assembly by pulling straight out. Place wing nuts and cap aside in safe place during inspection / cleaning (G-16).

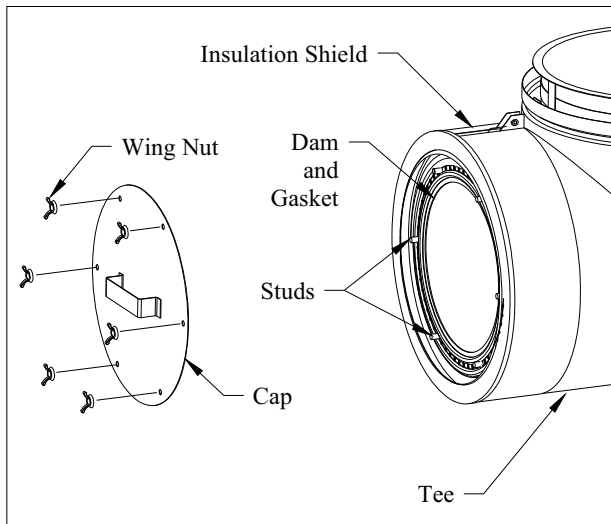
NOTE: IVSI and ZC models include a band of insulation around the circumference of the inner duct. Removal of this insulation is not required for access to duct for inspection / cleaning.

To Replace Cap After Inspection and Cleaning

(Replace assembly in reverse order of removal process.)

1. Align holes in No-Tool Cap over studs on dam. Guide cap over holes until cap contacts dam. Secure cap in place with wing nuts, insuring that all wing nuts are secured and pulling cap tightly against dam. (See Fig. G-16)
2. Carefully Guide No-Tool Cover back in place over assembly until it extends over outer wall of tee assembly. Secure in place by tightening bolt / wing nut. (See Fig. G-14 & G-15)

Fig. G-16



**FIELD INSTALLED GREASE DUCT ACCESS DOORS**

For Model N installations, it is permissible to install Listed Grease Duct Access Doors provided they are installed per the manufacturer's installation instructions.

**INTERCONNECTION WITH RECTANGULAR GREASE DUCTS**

As a general rule, Ampco grease duct systems are intended to be installed as complete systems without the use of other manufactured or generic components. However, Ampco recognizes the occasional need for a rectangular portion of the grease duct due to space limitations at certain locations within the system. In such case, it is permissible to transition to / from the Ampco grease duct to a code compliant, rectangular, welded steel grease duct system (by others) and back again. When such situations occur, Ampco will fabricate and supply single wall stainless steel (with code specified 0.043" minimum thickness) round to rectangular transition(s) of the correct dimensions and specifications to permit connection via fully welded (per code) attachment between the Ampco stainless steel transition(s) and the rectangular grease duct segment(s). (The round end of the transition will mate with the Ampco round grease duct without welding.)

Maintain proper minimum airspace clearances between any single wall rectangular duct and rectangular/round transitions and combustibles per applicable code. In most cases this minimum airspace clearance will be 18".

Where required by code, these transitions (and the rectangular portion of the system) are to be protected with a fire rated enclosure. Such enclosure may be either a field applied wrap system or separate fire protective shaft enclosure with an appropriate fire resistance rating. When installed with Model Z-Clear the fire rated enclosure system must extend to and overlap the adjacent section of Z-Clear a minimum of 6" and be mechanically secured to insure it remains in place.

## INLINE ACCESS DOOR

### Removal Procedure for Duct Inspection and Cleaning.

#### To remove Access Door for inspection and Cleaning:

1. NOTE: For Installations on single wall Model N Product proceed to step #3. Locate the Snap-Down latches securing the Outer Cover to the outer wall of the duct. Using your thumb or device such a flat head screwdriver, rotate the Arm of the Snap-Down latch to the open position (See Fig. G-17). Once all the Snap-Down latches are opened, remove Outer Cover and set it aside in a safe place during inspection / cleaning of the duct.
2. NOTE: For uninsulated model VSI ducts, proceed to step #3. For insulated IVSI and ZC models, a foil encapsulated Insulation Plug is used to insulate the duct and access door. Carefully remove the insulation plug from the wall cavity of the duct. (See Fig. G-18). Once the Insulation Plug is removed, set it aside in a safe place during inspection / cleaning of the duct.
3. Unscrew the Wing Nuts securing the Access Door to the Duct and remove Inner Access Door. Place Access Door and all fasteners aside in a safe place during inspection and cleaning of the duct (See Fig. G-19).

#### To replace Access Door after inspection and cleaning:

NOTE: Replace assembly in reverse order of removal process.

1. Install the Inner Access Door by aligning the bolt holes in the door with the studs protruding from the duct. Secure the Access Door in place with the Wing Nuts that were removed earlier (See Figs. G-18 & G-19).
2. NOTE: For uninsulated model VSI ducts, proceed to step #3. For insulated IVSI and ZC models, install the Insulation Plug (removed earlier), into the wall cavity of the duct, making sure that the entire opening in the duct is filled with the insulation (See Fig. G-20).
3. Center the Outer Cover (removed earlier), over the hole in the duct, making sure that an even amount of the outer wall is covered around the perimeter of the hole. Hold the cover in this location and rotate the Arm of the Snap-Down Latches to the closed position (See Fig. G-17). Ensure that all the Snap-Down Latches are in the closed position and that the outer cover is held securely in place.

Fig. G-17 – Inline Access Door

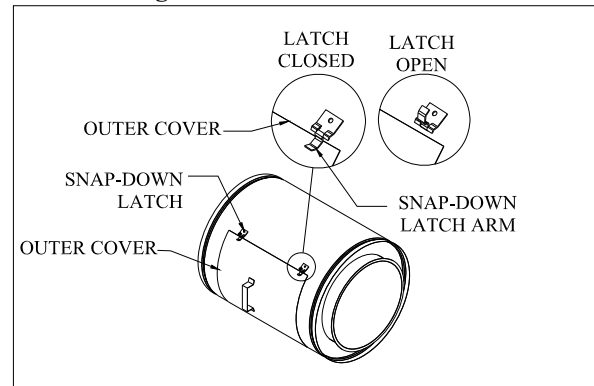


Fig. G-18

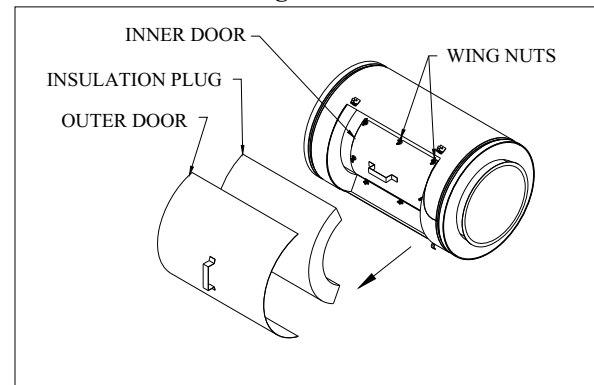


Fig. G-19

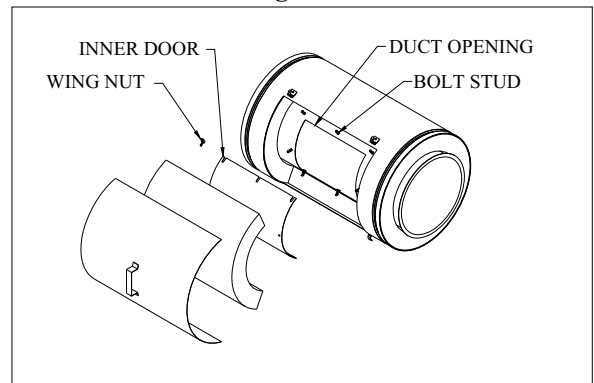
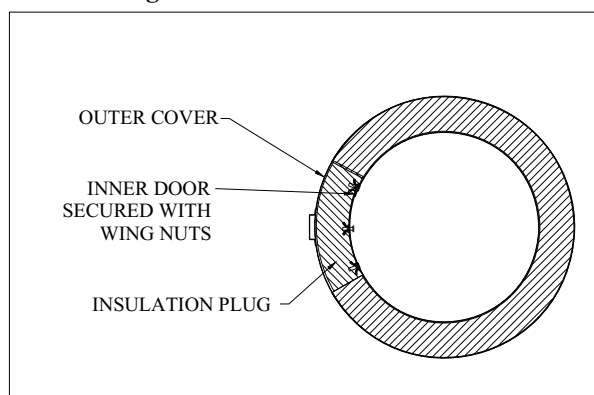


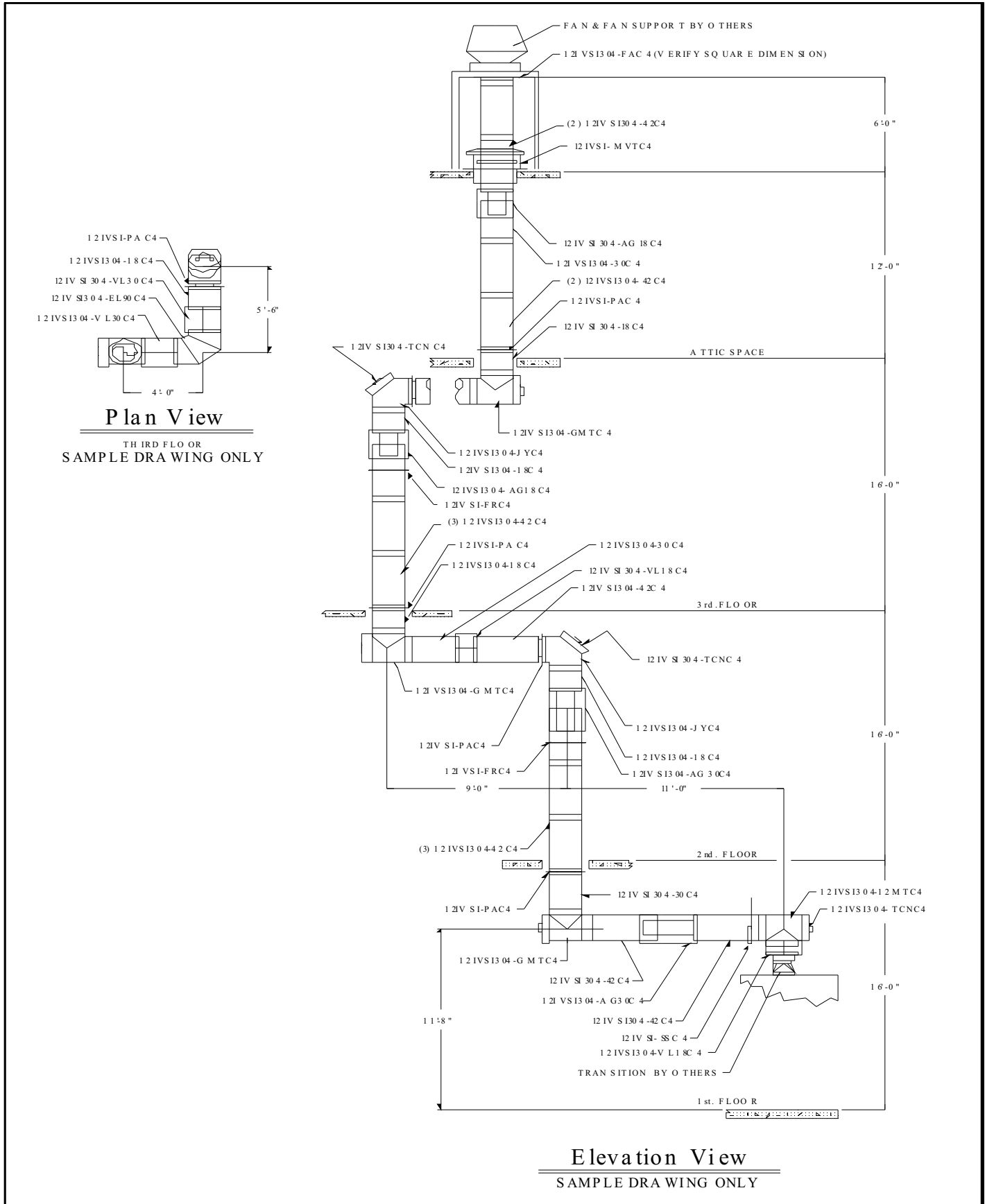
Fig. G-20 – Section View of IAD



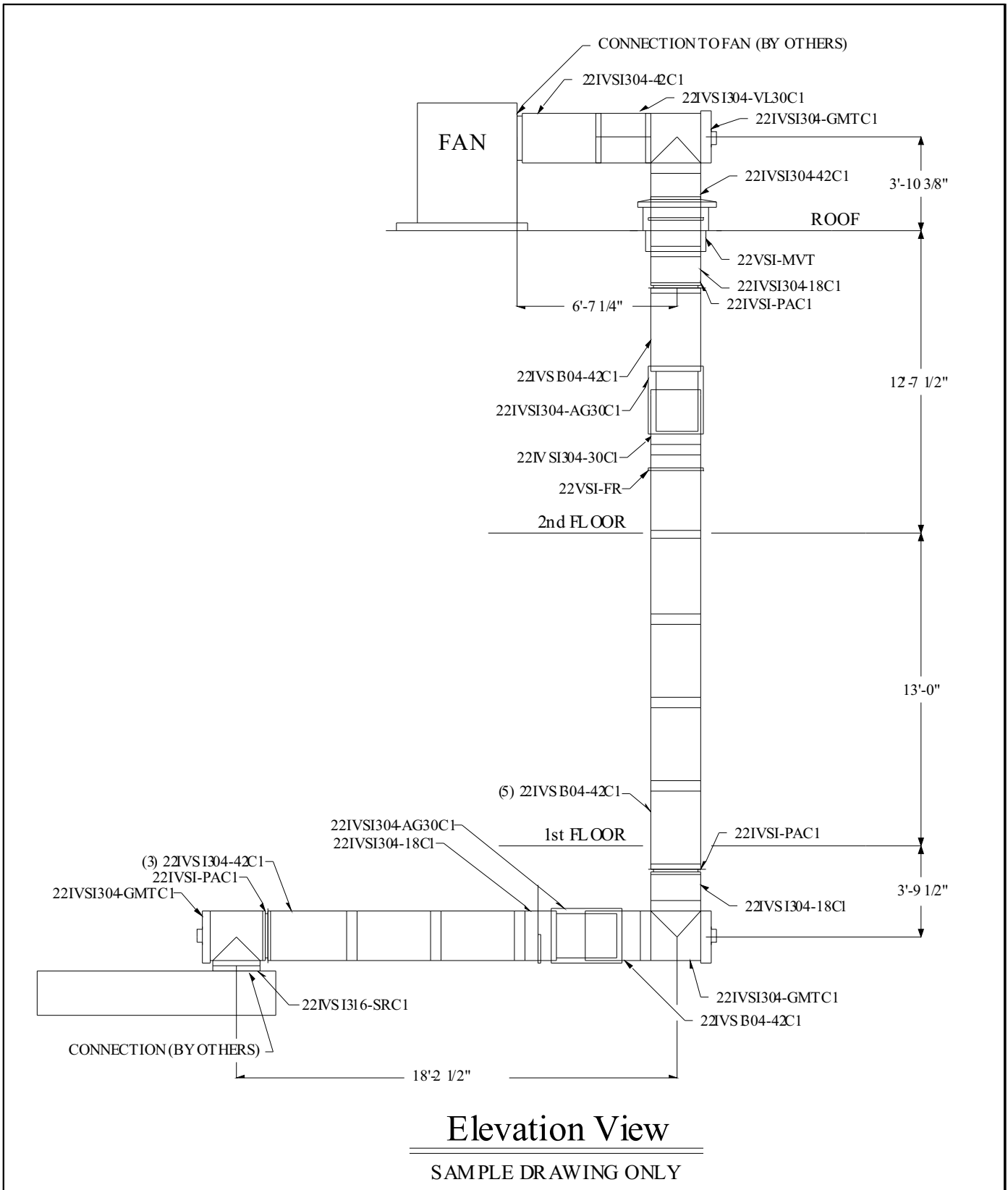


GREASE DUCT SAMPLE DRAWINGS

Fig. G-21 Sample Drawing (Grease Duct Installation)



**Fig. G-22 Sample Drawing (Grease Duct Installation)**





# INSTALLATION INSTRUCTION SUPPLEMENT

## MODEL VSI & IVSI FOR TYPE B GAS VENT



### **⚠ WARNING**

**Failure to follow these Installation Instructions could cause FIRE, CARBON MONOXIDE POISONING, OR DEATH. If you are unsure of Installation requirements, call the Phone Number listed on the front of these instructions.**

**READ AND FOLLOW THESE SUPPLEMENTAL INSTRUCTIONS IF THE MODEL VSI OR IVSI SYSTEM BEING INSTALLED INCLUDE LABELS CONFIRMING LISTING AS TYPE B GAS VENT.**

Model VSI and IVSI vent systems are also Listed by Underwriters Laboratories, Inc. (UL) for use as a Type B Gas Vent in accordance with the Standard for Gas Vent, UL-441.

This Installation Instruction Supplement includes very important information specific to the Type B Gas Vent application for use with Model VSI & IVSI systems. This information is intended only to supplement the main instructions found in this document. For complete guidelines for installation and maintenance of Model VSI & IVSI, see the main section of this document in conjunction with this instruction supplement.

Type B Gas Vent is intended for use only with Listed gas appliances incorporating draft hoods and other Listed gas appliances specified for use with Type B gas vent. When used in an application where the appliance is Listed for use with Type B Gas Vent, Model VSI and IVSI may be installed as Type B gas vent with the following clearances to combustibles:

Clearances for Type B Gas Vent		
Model	Diameter	Minimum Airspace Clearance to Combustibles
VSI	5" – 24"	1"
VSI	26" – 48"	2"
IVSI	5" – 48"	1"

If the appliance to which Model VSI or IVSI is attached is not Listed for use with Type B gas vent, refer to the main VSI/IVSI Installation Instructions and follow the installation guidelines for the flue gas temperature and pressure ratings applicable. VSI / IVSI installation as a Building Heating Appliance or 1400°F chimney may be required. If the application involves maximum flue gas temperatures in the range suitable for Type B gas vent (400°F maximum above ambient) but the appliance is not Listed for use with Type B gas vent, the Local Authority having Jurisdiction may accept the installation / use of such, at the clearances specified above, as an "Engineered System" per local code.

### REQUIRED PARTS

When installed as Type B Gas Vent in sizes 5" through 12" diameter, the Model VSI / IVSI system should incorporate either a Listed Type B Gas Vent termination cap or a Model "CT" termination cap in order to comply with UL441 wind test / cap requirements. Also, when installed as a Type B gas vent, ventilated roof assemblies are not required. However, proper minimum airspace clearances as noted above must be maintained.

### SURROUNDINGS / ENCLOSURE

When used as a Type B Gas Vent, Model VSI and IVSI may be enclosed in a chase fabricated from combustible materials. Check local codes to determine the required fire rating, if any, for such enclosures. When used as a Type B gas vent and extending up through any zone of a building outside that in which the heating appliance to which it is connected is located, Model VSI and IVSI should be provided with a fire rated enclosure. Such enclosure should have a fire resistance rating equal to or greater than that of the floor, wall, or roof assemblies through which it passes.

### POSTING OF NOTICES

When used as a Type B Gas Vent, a notice should be posted near the connection to the appliance indicating that the Model VSI / IVSI system, as installed, is to be used only with gas appliances producing flue gas temperatures not exceeding 400°F above ambient. The notice should also include a recommendation that the vent be inspected prior to the heating season to assure an unrestricted flue. For such purposes the cap may need to be removed and replaced after inspection.

Ampco Commercial/Industrial representatives throughout North America are qualified to provide field service to assist contractors, builders, engineers and architects in designing Boiler Stacks and Breechings, Grease Ducts, Diesel and Turbine Exhausts, Freestanding Stack Systems, and Residential Chimney and Gas Vent Systems. Contact the Ampco Regional Office nearest you for assistance.

**Commercial/Industrial Venting Products Sales Office**

Ampco

815 Kimberly Dr.

Carol Stream, IL 60188

Tel: 800.624.8642

Fax: 866.466.9335

[www.ampcostacks.com](http://www.ampcostacks.com)