

# HEATRIM PLUS

High Capacity  
Baseboard Radiation

## Submittal

### Specification

**ENCLOSURE:**

STYLE : "HeatRim Plus"

COLOR: White

FRONT: 18 Ga. Roll Formed  
Prepainted Steel

**BACKPLATE:** 22 Ga. Roll Formed  
Prepainted Steel

**DAMPER VANE:** Roll Formed  
Prepainted Steel

**ELEMENT:**  
TYPE: Cu/Al Mechanically  
Expanded  
Flared One End

**BRACKETS:** Die Formed 16 Ga.  
Prepainted Steel

**SLIDE SHOES:** High Temperature  
Nylon Snap On

**ACCESSORIES:** All overlapping,  
20 Ga. Steel with  
Snap On Fit and  
Baked Enamel Finish

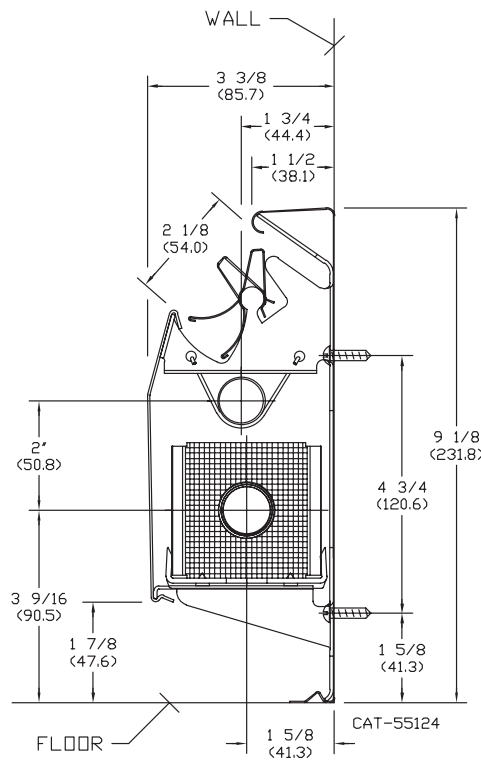

NOTE: DIMENSIONS IN "( )" ARE  
SHOWN IN MILLIMETERS.

### RATINGS

Model	GPM	Average Hot Water Temperature °F - BTU/Hr./Lin. Ft.								
		140°	150°	160°	170°	180°	190°	200°	210°	220°
3/4"	4	470	560	650	750	850	940	1040	1140	1240
	1	445	530	620	710	800	890	980	1080	1170
1"	4	455	540	630	730	820	920	1010	1120	1220
	1	430	510	600	690	780	870	960	1060	1150



260 North Elm St., Westfield, MA 01085  
(413) 564-5545 Fax: (413) 572-3764

www.sterlingheat.com

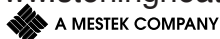

03/08

PROJECT: \_\_\_\_\_ DATE: \_\_\_\_\_

LOCATION: \_\_\_\_\_

ARCHITECT: \_\_\_\_\_

ENGINEER: \_\_\_\_\_

CONTRACTOR: \_\_\_\_\_

PO NUMBER: \_\_\_\_\_

# HEATRIM PLUS

High Capacity  
Baseboard Radiation

*Submittal*

## Specification

Furnish and install where shown on all plans/drawings, HeatRim Plus Finned Tube Enclosure and Element as described or approved equal of both quality and BTU capacity.

The front panel of the baseboard radiator enclosure, as called out HeatRim Plus, will be manufactured from 18 gauge pre-painted bonderized C.R.S. The backplate will be manufactured from 22 gauge pre-painted bonderized C.R.S. All lateral bends are to be roll formed to ensure continuity of all adjoining enclosures and accessories. The enclosure lengths are to be provided in 12 inch increments from 2 feet through 8 feet long. The front panel is to be fully engaged onto mounting brackets engaged with the back panel. A panel joiner piece is to be used where two pieces of enclosure are adjoining each other in a run. This is to be supplied in each 5', 6' and 8' assembly package.

All accessories will be die formed 20 gauge cold rolled steel and finished with a baked enamel finish. The accessories will overlap the installed enclosure and are to provide adjustment for make-up in the installed runs of enclosure. The accessories will extend to the floor. The accessories are to be enclosure height.

The brackets are to be of a one piece, die formed construction. The material is to be 16 gauge pre-painted bonderized C.R.S. The bracket is to be self locating for vertical positioning at installation. The bottom horizontal leg is to snap into bottom bend of the enclosure and is to support the element where slide shoes are located.

All elements are to be of the mechanically expanded type to ensure that proper fin to tube bonding is maximized. Copper/Aluminum elements are to be provided with one end mechanically swaged (flared) for proper assembly.

In the interest of product improvement, we reserve the right to make changes without notice.