

BEACON MORRIS "BTD" SERIES TUBULAR DUCT FURNACE



BTDS-1

DESCRIPTION

The Beacon Morris "BTD" Series Duct Furnace offers a highly efficient, extremely durable alternative to the traditional clam shell design. Designed with ease of service in mind, the BTD has an easy access control panel allowing access to the control board, gas valve and burner assembly. The unit is standard left hand access and is field convertible to right hand access.

Units are available in sizes 100 to 400 MBH. The "BTD" is certified by ETL as providing 82% thermal (combustion) efficiency.

TUBULAR HEAT EXCHANGER

The Beacon Morris tubular heat exchanger has been designed to provide maximum and uniform heat transfer. The low pressure drop associated with this design enables heated air to be evenly distributed to the conditioned space. This curved, nonwelded serpentine design experiences less thermally induced stress making it highly durable for significantly longer service life. All Beacon Morris tubular heat exchangers are constructed of heavy duty 20-gauge aluminized steel. Optional 409 stainless steel heat exchangers are also available.

DIRECT SPARK IGNITION SYSTEM

Beacon Morris "BTD" units utilize a direct spark, pilotless ignition of the burner, providing fast heat delivery. This highly reliable and efficient ignition system incorporates an integrated electronic control board to regulate the system sequence of operation, including an onboard LED indicator for simple troubleshooting.

VENTING

The Beacon Morris "BTD" unit heater is ETL certified in accordance with category III venting requirements. This certification allows units to be vented both vertically or horizontally using either single wall or double wall venting materials. Available as an accessory option, Beacon Morris offers a Combustion Air Inlet Kit that allows for concentric venting of both combustion and exhaust air systems through one termination.

The BTD duct furnace can be field converted to separated combustion using the optional accessory "X8 - Combustion Air Inlet Kit" or the "X9 - Air Inlet Kit". Once converted, a power venting system draws a controlled quantity of combustion air from outside the building. The same system exhausts flue products to the outside. The burners and flue system are enclosed within the unit; thus, the entire combustion process is unaffected by the atmosphere in the space where the heater is located. Separated combustion units are designed to be installed where dusty, dirty or mildly corrosive conditions exist or where high humidity or slightly negative pressures prevail.



CAUTIONS

Combustion air and vent systems must be installed in accordance with current National Fuel Gas Code or Installation Code, Installation Code for Natural Gas Burning Appliances and Equipment (Canda) and any local and state codes. Units should not be installed where negative pressures are significant, where vapor containing chlorine or fluorine may be present or in any areas classified as "hazardous."

STANDARD FEATURES

- In-Shot Burner Design
- 20-Gauge Steel Jacket with Baked Enamel Finish
- Double Wall Construction
- Main Control Panel
- 115/1/60 Supply Voltage
- 115/24 Volt Controls transformer
- Redundant Single-Stage Gas Valve
- 20-Gauge Aluminized Steel Heat Exchanger
- For Natural or Propane Gas
- Power Vented
- 82% Thermal Efficiency
- 10 Year Heat Exchanger, Flue Collector and Burner Warranty
- Four Point Suspension
- Direct Spark Ignition
- Easy Access Control Panel
- Left Hand Control Access – Field Convertible to Right Hand

OPTIONAL FEATURES

- 409 Stainless Steel Heat Exchanger and Flue Collector
- High Pressure Regulator 1/2 - 35 PSI
- Two-Stage and Various Electronic Modulation Gas Controls
- Supply Voltages (Field Mounted Transformer): 208 & 230/1/60 and 208, 230, 460, 575/3/60
- Single and Two-Stage Mercury Free Ductstats and Thermostats
- Line Voltage Thermostat
- Locking Thermostat Cover
- Low Ambient Control
- Vent Caps
- Air Inlet Kit (For conversion to separated combustion and two roof or wall penetrations. Includes a vent cap for the combustion air inlet pipe)
- Combustion Air Inlet Kit (For conversion to separated combustion and a single roof or wall penetration)
- Stainless Steel Drip Pan
- 24V SPST Relay
- Horizontal and Vertical Louvers



03/2014

260 North Elm Street • Westfield, MA 01085
Tel: (413) 562-5423 Fax: (413) 572-3764
www.beacon-morris.com



PROJECT: _____

UNIT TAG: _____

DIMENSIONAL DATA

Table 1 - Tubular Duct Furnace Dimensions

Unit Capacity	100	150	200	250	300	350	400
Dimensional Data - inches (mm)							
"A" Overall Unit Height	10.3 (262)	13.7 (348)	17 (432)	20.2 (513)	23.5 (597)	26.7 (678)	30 (762)
"B" Height to Centerline Flue	7.6 (193)	10.5 (267)	11.9 (302)	6.8 (173)	8.4 (213)	10 (254)	11.6 (295)
"C" Height to Gas Connection	2.5 (64)	3.7 (94)	5.3 (135)	7 (178)	7 (178)	8.7 (221)	10.3 (262)
"D" Opening Height, Front & Rear	8.5 (216)	11.7 (297)	15 (381)	18.2 (462)	21.5 (546)	24.7 (627)	28 (711)
"E" Overall Unit Depth	32.7 (831)	32.7 (831)	32.7 (831)	33.5 (851)	33.5 (851)	33.5 (851)	33.5 (851)
"F" Flue Size Diameter	5 (127)	5 (127)	5 (127)	6 (152)	6 (152)	6 (152)	6 (152)
"G" Air Inlet Size Diameter	5 (127)	5 (127)	5 (127)	6 (152)	6 (152)	6 (152)	6 (152)
Gas Inlet, Natural Gas - inch	1/2	1/2	1/2	3/4	3/4	3/4	3/4
Gas Inlet, LP Gas - inch	1/2	1/2	1/2	3/4	3/4	3/4	3/4
Approximate Unit Weight - lb	160	221	250	270	296	321	355
(kg)	(73)	(100)	(113)	(122)	(134)	(146)	(161)
Approximate Ship Weight - lb	270	331	360	403	429	454	488
(kg)	(122)	(150)	(163)	(183)	(195)	(206)	(221)

Figure 1 - Tubular Duct Furnace Dimensions

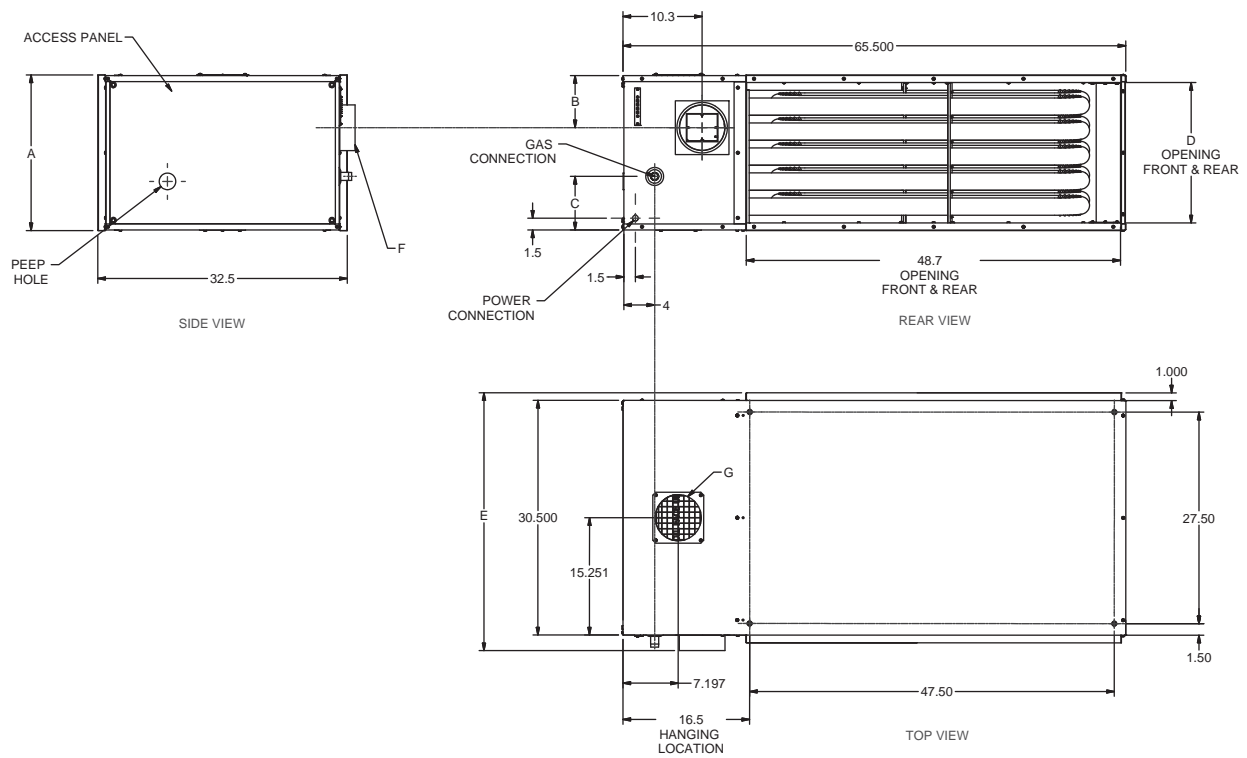

D9362

PERFORMANCE DATA

Table 2 - Tubular Duct Furnace Performance Data

UNIT SIZE	INPUT		OUTPUT MBH (kW)	Min. CFM (cu. m/s)	Temp. Rise Deg. F (Deg. C)	P.D. in. W.C. (kPa)	Max. CFM (cu. m/s)	Temp. Rise Deg. F (Deg. C)	P.D. in. W.C. (kPa)
	(Max.) MBH (kW)	(Min.) MBH (kW)							
100	100 (29.3)	50 (14.6)	82 (24.0)	758 (0.357)	100 (56)	0.07 (0.017)	2528 (1.193)	30 (17)	0.65 (0.16)
150	150 (43.9)	75 (21.9)	123 (36.0)	1137 (0.536)	100 (56)	0.03 (0.007)	3792 (1.789)	30 (17)	0.44 (0.11)
200	200 (58.6)	100 (29.3)	164 (48.0)	1517 (0.715)	100 (56)	0.04 (0.009)	5057 (2.386)	30 (17)	0.54 (0.13)
250	250 (73.2)	125 (36.6)	205 (60.0)	1896 (0.894)	100 (56)	0.08 (0.019)	6321 (2.983)	30 (17)	0.76 (0.19)
300	300 (87.8)	150 (43.9)	246 (72.0)	2275 (1.074)	100 (56)	0.03 (0.007)	7585 (3.579)	30 (17)	0.69 (0.16)
350	350 (102.5)	175 (51.2)	287 (84.1)	2654 (1.252)	100 (56)	0.07 (0.017)	8849 (4.176)	30 (17)	0.76 (0.19)
400	400 (117.1)	200 (58.6)	328 (96.1)	3034 (1.431)	100 (56)	0.08 (0.019)	10,114 (4.773)	30 (17)	0.70 (0.17)

Ratings are shown for unit installations at elevations between 0 and 2,000 feet (610m). For unit installations in U.S.A. above 2,000 feet (610m), the unit input must be field derated 4% for each 1,000 feet (305m) above sea level; refer to local codes, or in absence of local codes, refer to the latest edition of the National Fuel Gas Code, ANSI Standard Z223.1 (NFPA 54). For installations in Canada, any references to deration at altitudes in excess of 2,000 feet (610m) are to be ignored. At altitudes of 2,000 to 4,500 feet (610 to 1372m), the unit must be field derated and be so marked in accordance with the ETL certification. See installation manual for U.S.A. and Canadian field deration information.

Figure 2

Temperature Rise and Pressure Drop Graph

