



**Wilo SP Series  
Submersible Sump Pumps ECS**

**ECS19-15.25**

**ECS22-15.33**

**ECS24-15.50**

**Installation and operating instructions**

## PREINSTALLATION CHECK

Inspect this pump before it is used. Occasionally, pumps can be damaged during shipping. If the pump or components are deformed, cracked, or there is an oil leak, call us Toll Free at: 866-945-6872, or e-mail: info@wilo-usa.com Monday – Friday between 8 a.m. – 6 p.m., EST. Do not return the pump to the store. ATTEMPTING TO USE A DAMAGED PUMP can result in personal injury or death!

### 1. DESCRIPTION

This Wilo submersible sump pump is designed for home sump applications. The pump is built with overload thermal protections and auto reset. The pump is equipped with a 10' 3-prong grounding-type power cord, and assembled with vertical float switch. This pump operates automatically. Ball bearings on motor shafts never need lubrication. Stainless steel pump housing, screws, cast iron volute, and non-clog reinforced thermoplastic impeller provide variety applications including drainage flooded basements, laundry. Pump only water with this pump. This pump has not been tested or approved for use in swimming pools or in salt-water marine areas.



**Do not pump flammable or explosive liquids such as oil, gasoline, kerosene, ethanol, etc. Do not use in the presence of flammable or explosive vapors. Using this pump with or near flammable liquids can cause explosion or fire, resulting in serious personal injury and/or property damage.**

### 2. SPECIFICATIONS

- Power supply required..... 115V, 60 HZ
- Water temperature range..... Max.77°F (25°C)
- Individual branch circuit required ..... 15 Amp minimum
- Discharge Connection..... 1-1/2" FNPT/1-1/4" FNPT (with adaptor)
- Motor duty..... Continuous
- Power cord..... SJTW, 18AWG/3C, 10ft

**NOTICE:** This unit is not designed to be used to pump salt water or brine! Use with salt water or brine will void warranty.

### 3. CONSTRUCTION

- Motor housing..... Stainless Steel
- Volute (Intake screen)..... Cast Iron
- Impeller..... Reinforced thermoplastic

### 4. PERFORMANCE

Table 1 :

Model	HP	GPM of Water @ Total Feet of Head					Max. Head
		0	5ft. (1.5m)	10ft. (3 m)	15ft.(4.6 m)	20 ft. (6.1 m)	
ECS24-15.50	1/2	70	67	55	38	25	24 ft. (7.3 m)
ECS22-15.33	1/3	62	57	40	18	0	20ft(6.1m)
ECS19-15.25	1/4	57	53	38	18	0	18ft(5.3m)

## 5. GENERAL SAFETY INFORMATION

This pump is made of high-strength, corrosion-resistant materials. It will provide trouble-free service for a long time when properly installed, maintained, and used. However, inadequate electrical power to the pump, dirt, or debris may cause the pump to fail, eventually bringing about additional water damage. To minimize the potential for water damage due to pump failure. Please carefully read the manual and follow the instructions regarding common pump problems and remedies or call one of our pump experts at 866-945-6872.

**The following are the general safety requirements. Failure to follow them could cause serious personal injury and/or property damage.**

### **Warning**

**For your protection and safety, always follow these general rules with pumps:**

- ✓ **Always disconnect the pump from its power source before installing, inspecting, maintaining, or repairing.**
- ✓ **Do not stand in water when the pump is connected**
- ✓ **Do not touch the pump housing while it is operating, as the pump may be HOT and can cause serious skin burns.**
- ✓ **Do not disassemble the motor housing. The motor has NO repairable internal parts, and disassembling may cause water leakage or dangerous electrical wiring issues.**
- ✓ **Do not lift pump by power cord or switch cord.**

### **Additional Safety Precautions**

1. Know the pump applications, limitations, and potential hazards.
2. Make certain the electrical power source is adequate for the requirements of the pump.
3. ALWAYS disconnect the power to the pump before servicing.
4. Release all pressure (drain all water) within system before servicing any component.
5. Secure discharge line before starting pump. An unsecured discharge line will whip, possibly causing personal injury and/or property damage.
6. Secure the pump on a solid base to keep the pump vertical and above mud and sand during operation to maximize pumping efficiency and prevent clogging and premature pump failure.
7. Check that all pipe connections are tight to minimize leaks.
8. Connect the pump DIRECTLY to a grounded, GFCI outlet.
9. Extension cords may not deliver sufficient voltage to the pump motor. Extension cords present a life threatening safety hazard if the insulation becomes damaged or the connection ends fall into water.
10. Make certain the electrical circuit to the pump is protected by a 15 Amp or larger fuse or circuit breaker.
11. Periodically inspect the pump and system components to be sure the pump inlets are free of mud, sand, and debris. DISCONNECT THE PUMP FROM THE POWER SUPPLY BEFORE INSPECTING.
12. Do not handle pump or pump motor with wet hands or when standing on wet or damp surface, or in water.
13. Wear safety glasses at all times when working with pumps.
14. Follow all electrical and safety codes, particularly the National Electrical Code (NEC) and in the workplace, the Occupational Safety and Health Act (OSHA).
15. This unit is designed only for use on 115 volts (single phase), 60 Hz, and is equipped with an approved 3-conductor cord and 3-prong grounded plug. DO NOT REMOVE THE GROUND PIN UNDER ANY CIRCUMSTANCES. The 3-prong plug must be directly inserted into a properly installed and grounded 3-prong, grounding-type receptacle. **Do not use**

**this pump with a 2-prong wall outlet.** Replace the 2-prong outlet with a properly grounded 3-prong receptacle (a **GFCI outlet**) installed in accordance with the National Electrical Code and local codes and ordinances. All wiring should be performed by a qualified electrician.

- 16. Protect the electrical cord from sharp objects, hot surfaces, oil, and chemicals. Avoid kinking the cord. **Do not use damaged or worn cords.**

## 6. INSTALLATION



**Always use the handle to lift the pump. Never use the power cord to lift the pump. To avoid skin burns, unplug the pump and allow time for it to cool after periods of extended use.**

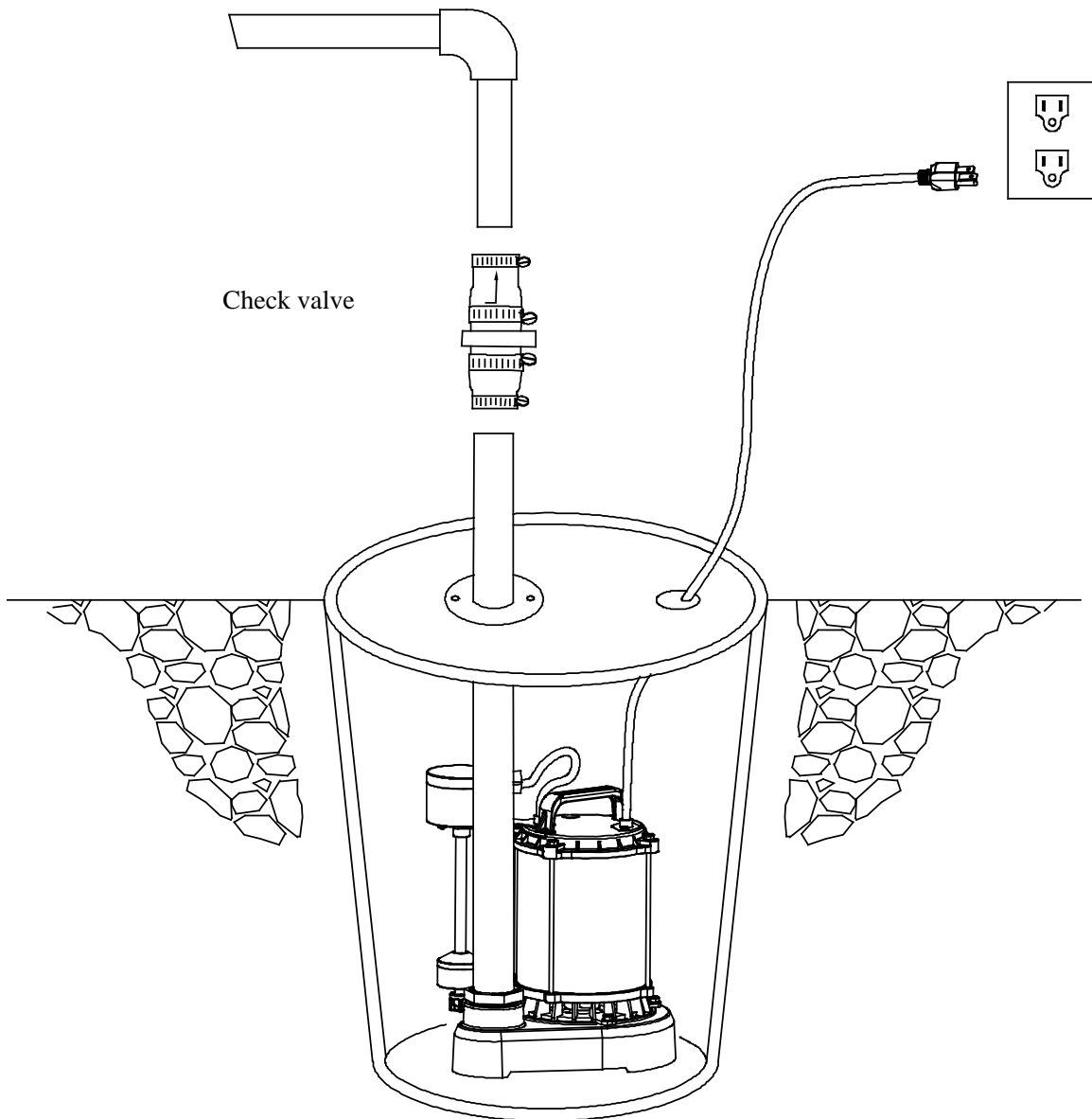

Picture 1

1. Install the pump in sump pit with minimum diameter of 18" (46cm). Sump pit depth should be 30" (76cm). Construct sump pit of tile, concrete, steel, or plastic. Check local codes for approved materials and for proper installation.
2. Clean sump pit of small stones, gravel, or mud. Secure the pump on a level, solid base. Do not suspend the pump by the discharge pipe, hose, or power cord.
3. Install discharge plumbing and a check valve in the vertical pipe to prevent flow backwards through the pump when it shuts off. Use rigid plastic pipe and wrap threads with Teflon tape, **NOT pipe joint compound**. Screw pipe into pump hand tight plus 1-1/2 turns.
4. After the installation of the necessary plumbing and check valve, follow the glue manufacturer's instructions for safety precautions and curing time. The pump is ready for operation.
5. Pump is designed for 115 V., 60Hz, operation and requires a minimum 15 amp individual branch circuit.
6. Check the pump by filling the sump pit with water and observe the pump's operation through one complete cycle. Make sure the pump cannot move in the sump and float switch moves freely up and down.

## 7. OPERATION

### Warning

**Do not handle this pump or plug in or unplug this pump with wet hands or while standing in water, unless you are certain all power has been turned off to the pump. Remember, the pump should be connected only to a properly grounded, GFCI outlet.**

**Running the pump without sufficient water will damage the pump and void the pump's warranty.**

Make certain the pump is submerged in water. Running the pump dry can damage the shaft seal.

1. When the float switch moves up over the pump, the pump will start operating. The water will be pumped out. When the water lowers to certain level, the float switch will turn off the pump. This pump also can operate manually if the switch fails. Directly plug the power cord plug into a 115V GFCI power outlet. The pump will pump water out.

The motor is equipped with an automatically resetting thermal overload protector. If the motor gets too hot, the overload protector will shut off the pump before it is damaged. When the motor has cooled sufficiently, the overload protector will reset, and the motor will restart.

**NOTICE:** If the overload protector stops the pump repeatedly, disconnect the power from the pump and check to find the problem. Low voltage, a long extension cord, clogged impeller, screen blocked by debris, or water that is too hot can cause motor overheating.

## 8. TROUBLESHOOTING

Do not disassemble the motor housing. This pump has NO repairable internal parts, and disassembly may cause an oil leak or dangerous electrical wiring conditions.

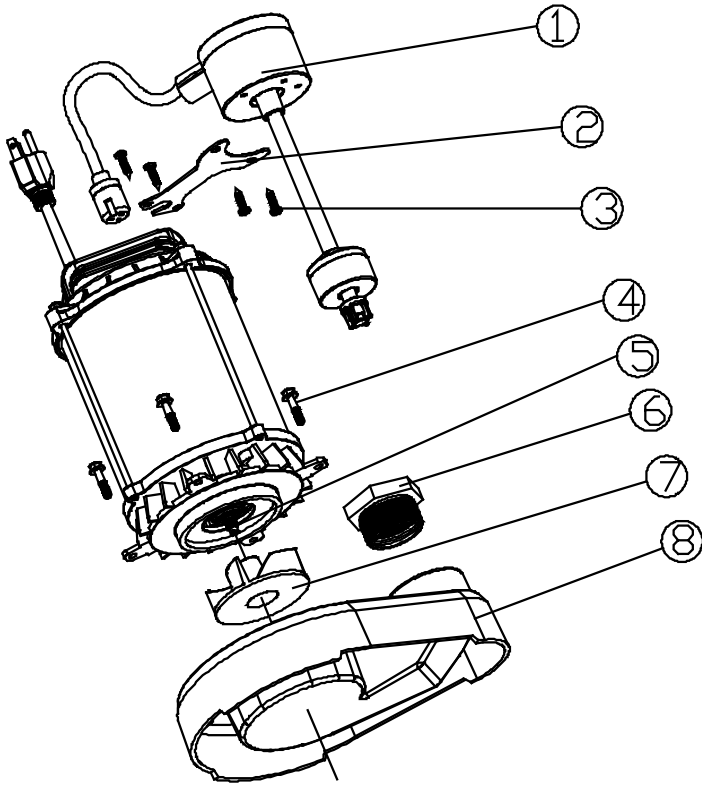

No.	Description	Qty.
1	Vertical float switch	1
2	Float bracket	1
3	Screw	4
4	Screw	4
5	Shaft	1
6	Adaptor	1
7	Impeller	1
8	Pump body	1

Picture 2

Table 2: Troubleshooting Common Pump Problems

Problem	Possible Cause	Corrective Action
Pump does not start or run	<ol style="list-style-type: none"> <li>1. Blown fuse</li> <li>2. Tripped breaker</li> <li>3. Plug disconnected</li> <li>4. Corroded plug</li> <li>5. Thermal overload</li> <li>6. Motor failed</li> <li>7. Float switch failed</li> </ol>	<ol style="list-style-type: none"> <li>1. Replace fuse</li> <li>2. Reset breaker</li> <li>3. Secure plug</li> <li>4. Clean plug prongs</li> <li>5. Unplug for 30 minutes, then plug in</li> <li>6. Replace pump</li> <li>7. Replace switch</li> </ol>
Pump operates but pumps little or no water	<ol style="list-style-type: none"> <li>1. Screen blocked</li> <li>2. Check valve blocked</li> <li>3. Debris caught in impeller or discharge</li> </ol>	<ol style="list-style-type: none"> <li>1. Clean screen</li> <li>2. Clean check valve</li> <li>3. Remove debris and reassemble impeller</li> </ol>
Pump starts and stops too often	<ol style="list-style-type: none"> <li>1. Backflow of water from piping, check valve leaking</li> <li>2. Float switch failed</li> </ol>	<ol style="list-style-type: none"> <li>1. Install or replace check valve</li> <li>2. Replace switch.</li> </ol>
Pump will not shut off	<ol style="list-style-type: none"> <li>1. Float obstructed</li> <li>2. Defective float switch</li> </ol>	<ol style="list-style-type: none"> <li>1. Remove obstruction and make sure the switch moves freely</li> <li>2. Replace switch</li> </ol>

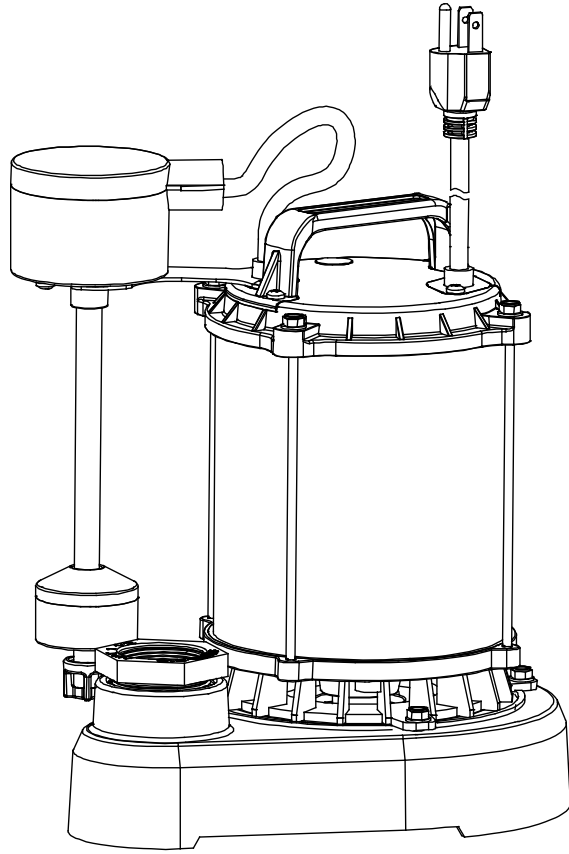

Wilo USA LLC  
1290 N 25th Ave  
Melrose Park, IL 60160

Tel: 866-945-6872  
Fax: 708-338-9455  
Email: [info@wilo-usa.com](mailto:info@wilo-usa.com)  
Web: [www.wilo-usa.com](http://www.wilo-usa.com)

Wilo Canada Inc.  
Bay 7-2915 10th Ave NE  
Calgary, AB T2A 5L4

Tel: 866-945-6236  
Fax: 403-277-9456  
Email: [info@wilo-canada.com](mailto:info@wilo-canada.com)  
Web: [www.wilo-canada.com](http://www.wilo-canada.com)

Wilo Mexico  
Managua No 978, Colonia Lindavista  
07300 México, D.F., México

Tel: + 52 55 5586 3209  
Fax: + 52 55 5586 3209  
Email: [info@wilo.com.mx](mailto:info@wilo.com.mx)  
Web: [www.wilo-mexico.com](http://www.wilo-mexico.com)

