

Submittal Data Sheet

Wilco ECS - Sump/Effluent Pumps



Wilco ECS



Project:	
Engineer:	
Contractor:	
Submitted By:	Date:
Approved By:	Date:

Tag #	Model #	Flow	Head	HP	Cycle	Phase	Voltage	RPM
	ECS19-15.25				60Hz	1	115	3450
	ECS22-15.33				60Hz	1	115	3450
	ECS25-15.50				60Hz	1	115	3450

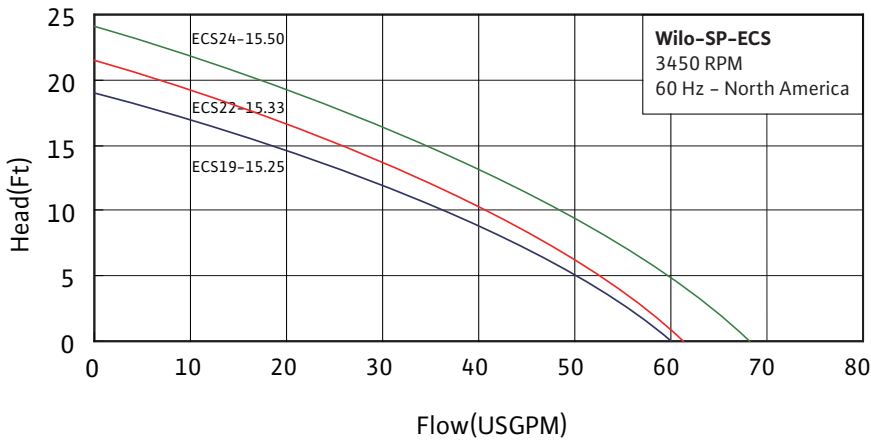

Technical Data

Temp Range:	Max.77°F (25°C)
Power Supply	1~115
Discharge Size:	1-½" NPT / 1-¼" NPT (with adaptor)

Materials of Construction

Motor Housing	Stainless Steel
Pump volute	Cast Iron
Impeller	Thermoplastic

Motor Data

Model	P2 [HP]	Phase [-]	FLA [A]	Voltage [V]
ECS19-15.25	¼	1	3.8	115
ECS22-15.33	½	1	4.9	115
ECS24-15.50	¾	1	6.3	115

Applications

- Drainage
- Sump & De-watering

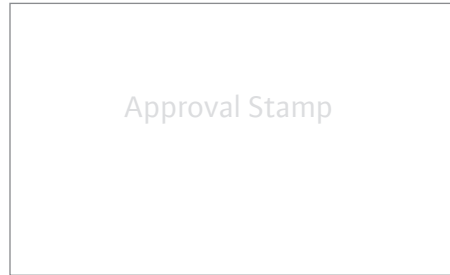
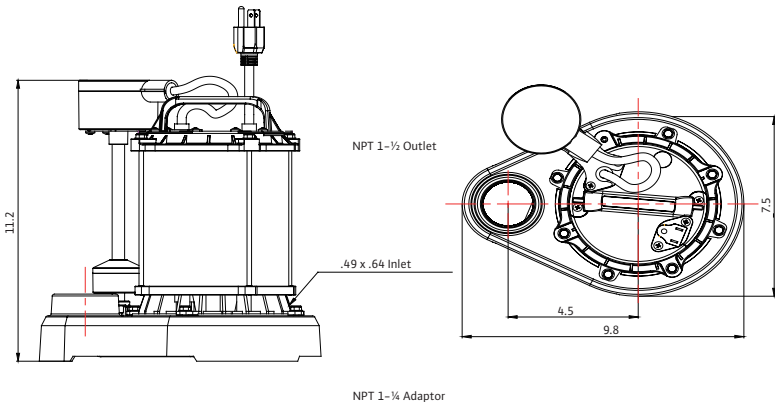

WILO USA LLC

Tel: (866) 945-6872 Web: www.wilo-usa.com
 Fax: (708) 338-9455 Email: info@wilo-usa.com

WILO Canada Inc.

Tel: (866) 945-6236 Web: www.wilo-canada.com
 Fax: (403) 277-9456 Email: info@wilo-canada.com

WILO Mexico

Tel: +52 55 5586 3209 Web: www.wilo-mexico.com.mx
 Fax: +52 1 55 5413 4165 Email: info@wilo.com.mx