

PETITE•9

High Capacity
Baseboard Radiation

Submittal

Specification

ENCLOSURE:

STYLE : "Petite•9"

COLOR: White

FRONT: 18 Ga. Roll Formed
Prepainted Steel

BACKPLATE:

22 Ga. Roll Formed
Prepainted Steel

DAMPER VANE:

Roll Formed
Prepainted Steel

ELEMENT:

TYPE: Cu/Al Mechanically
Expanded
Flared One End

BRACKETS:

Die Formed 16 Ga.
Prepainted Steel

SLIDE SHOES:

High Temperature
Nylon Snap On

ACCESSORIES:

All overlapping,
20 Ga. Steel with
Snap On Fit and
Baked Enamel
Finish

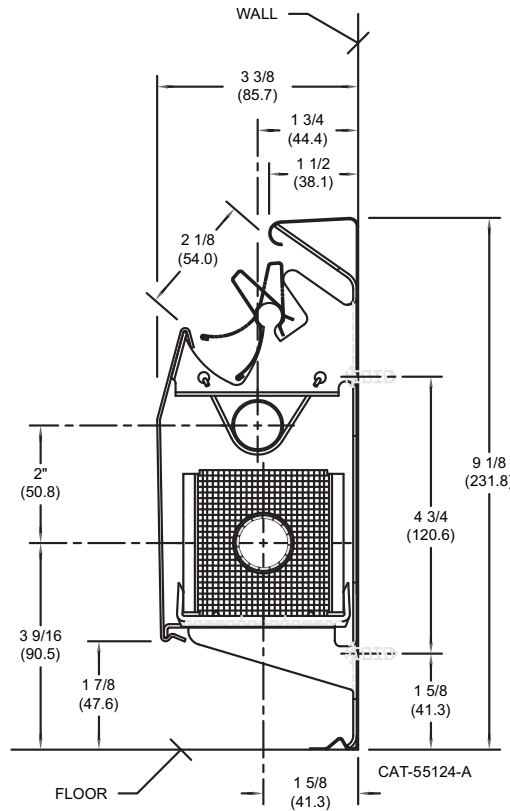

NOTE: DIMENSIONS IN "()" ARE
SHOWN IN MILLIMETERS.

RATINGS

Model	GPM	Water Flow Rate LB./HR.	Average Hot Water Temperature °F - BTU/Hr./Lin. Ft.								
			140°	150°	160°	170°	180°	190°	200°	210°	220°
P9 3/4"	4	2000	470	560	650	750	850	940	1040	1140	1240
	1	500	445	530	620	710	800	890	980	1080	1170
P9 1"	4	2000	455	540	630	730	820	920	1010	1120	1220
	1	500	430	510	600	690	780	870	960	1060	1150



260 North Elm St., Westfield, MA 01085
(413) 564-5545 Fax: (413) 572-3764

www.sterlingheat.com

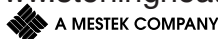

PROJECT: _____ DATE: _____

LOCATION: _____

ARCHITECT: _____

ENGINEER: _____

CONTRACTOR: _____

PO NUMBER: _____

Specification

Furnish and install where shown on all plans/drawings, Petite•9 Finned Tube Enclosure and Element as described or approved equal of both quality and BTU capacity.

The front panel of the baseboard radiator enclosure, as called out Petite•9, will be manufactured from 18 gauge pre-painted bonderized C.R.S. The backplate will be manufactured from 22 gauge pre-painted bonderized C.R.S. All lateral bends are to be roll formed to ensure continuity of all adjoining enclosures and accessories. The enclosure lengths are to be provided in 12 inch increments from 2 feet through 8 feet long. The front panel is to be fully engaged onto mounting brackets engaged with the back panel. A panel joiner piece is to be used where two pieces of enclosure are adjoining each other in a run. This is to be supplied in each 5', 6' and 8' assembly package.

All accessories will be die formed 20 gauge cold rolled steel and finished with a baked enamel finish. The accessories will overlap the installed enclosure and are to provide adjustment for make-up in the installed runs of enclosure. The accessories will extend to the floor. The accessories are to be enclosure height.

The brackets are to be of a one piece, die formed construction. The material is to be 16 gauge pre-painted bonderized C.R.S. The bracket is to be self locating for vertical positioning at installation. The bottom horizontal leg is to snap into bottom bend of the enclosure and is to support the element where slide shoes are located.

All elements are to be of the mechanically expanded type to ensure that proper fin to tube bonding is maximized. Copper/Aluminum elements are to be provided with one end mechanically swaged (flared) for proper assembly.

In the interest of product improvement, we reserve the right to make changes without notice.