

Installation Manual  
Modulating Module 0100  
Version 1.10



MOD-0100

---

HBX Control Systems Inc.



## HBX MOD-0100 MODULATING MODULE

### INTRODUCTION

The MOD-0100 Expansion Module is designed to be integrated with the HBX CPU-1000 HVAC Controller; it is not a stand-alone control device. The purpose and function of the MOD-0100 is to provide system expansion capabilities. Its primary use is to control modulating devices such as boilers and valves. For example, 1 CPU-1000 + 1 MOD-0100 can provide a total of 2 on/off stages and 2 modulating stages (when configured as a staging control).

The CPU-1000 by itself does not have the capability to run modulating devices. In conjunction with the MOD-0100 the CPU-1000 can run up to 5 modulating devices. The MOD-0100 has a spare thermistor input with no fixed function. The installer may choose to run the spare thermistor as; a room sensor, or a setpoint sensor. The spare demand signal has no dedicated function at the time of print.

The position of setpoint sensors (thermistors) is critical to the correct operation of the Control. Pay special attention to the wiring of setpoint sensors in relation to actuators, pumps, and multiple boiler stage relays.

A combination of Modules are designed to tackle a variety of applications, using a maximum of \*six Modules in unison with a single CPU-1000 Control Unit. The sequence in which the Modules are connected is very important. Install the Modules that you are utilizing in the following order: CPU-1000, Modulating Module, Boiler Module, Pump Module, and Setpoints Modules.

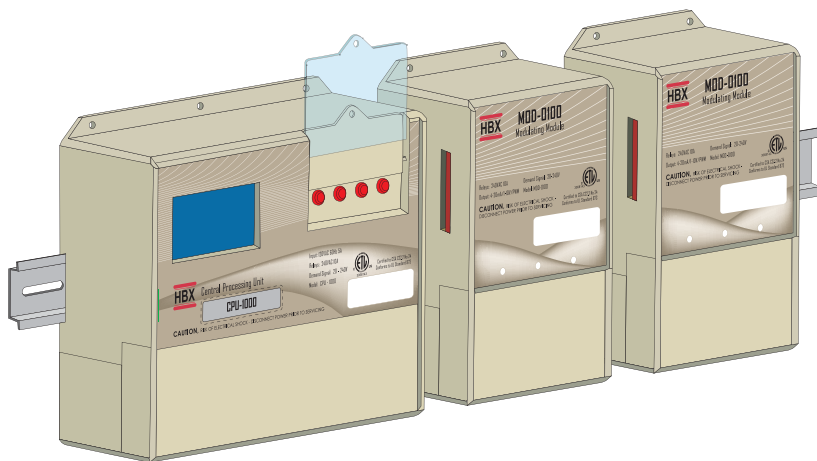

**\*More than six Modules can be connected to the CPU-1000 as the MOD Modules are not dependent on the CPU to power the relays.**

The MOD-0100 is designed to be wall mounted, DIN rail mounted, or installed inside a separate electrical enclosure. The unit should be mounted inside and be protected from falling water and high humidity conditions. With all the covers in place it is designed to protect any individual from accidental electrical shock.

## INSTALLATION PROCEDURE

Place the CPU-1000 and desired Expansion Modules on a flat surface. Align the 32-Pin connector into the holes on the Expansion Module and gently push into place. Next slide the CPU-1000 onto the 32-Pin connection by carefully matching up the holes and pins. When installed correctly there is virtually no gap between units. With power applied to the assembly, the first (green) LED should be illuminated on each Expansion Module. This lit, green LED serves as confirmation of both electrical and communications continuity.

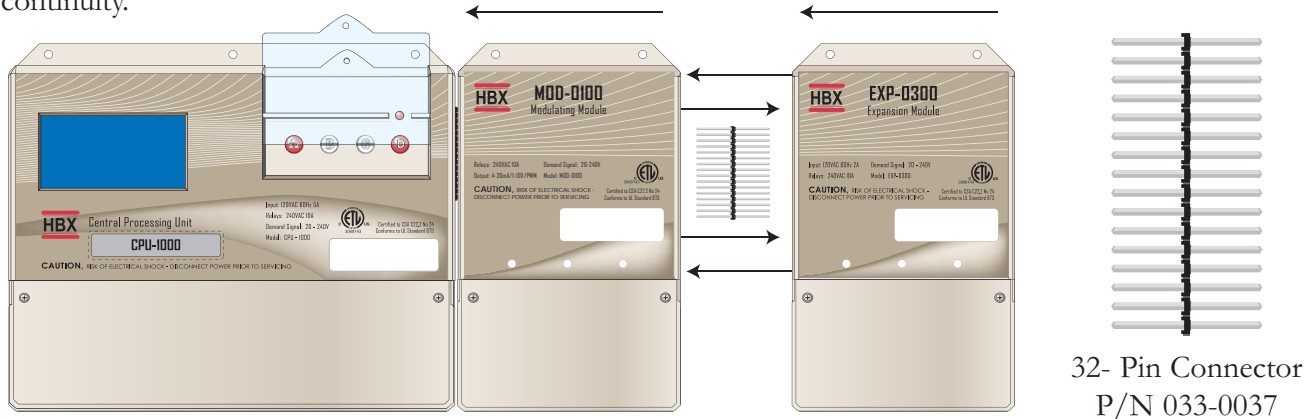

## TERMINAL DESIGNATIONS

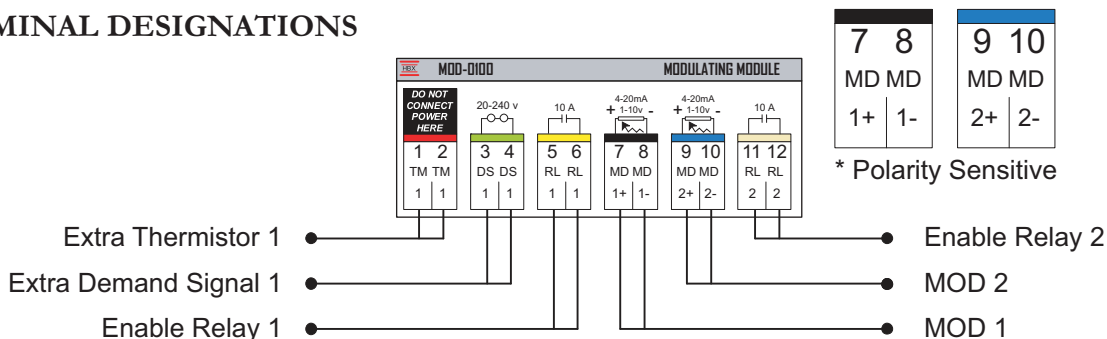

Extra Thermistor 1 - Gives you many choices.  
E.g. Room sensor or setpoint sensor.

**\* Thermistor inputs are designed for 10K Ohm thermistors and must never be subjected to any external power supply (voltage or current).**

Extra Demand Signal 1 - Any heat demand signal powered by 20 - 240VAC. E.g. 24VAC thermostat (future applications).

Enable Relay 1 - This relay is the default relay for enabling the first modulating boiler.

Enable Relay 2 - This relay is the default relay for enabling the second modulating boiler.

**\* Enable Relays 1&2 are dry contacts and rated for a max of 10Amps.**

MOD 1 - This output carries the modulating signal to modulate the device number 1. This output can be configured for 4-20mA, or 1-10v.

MOD 2 - This output carries the modulating signal to modulate the device number 2. This output can be configured for 4-20mA, or 1-10v.

**\* Outputs are selectable on the back of the Expansion Module. Each output can be set to either of the selectable outputs 4-20mA, or 1-10v.**

## MAIN PARTS AND LABELS

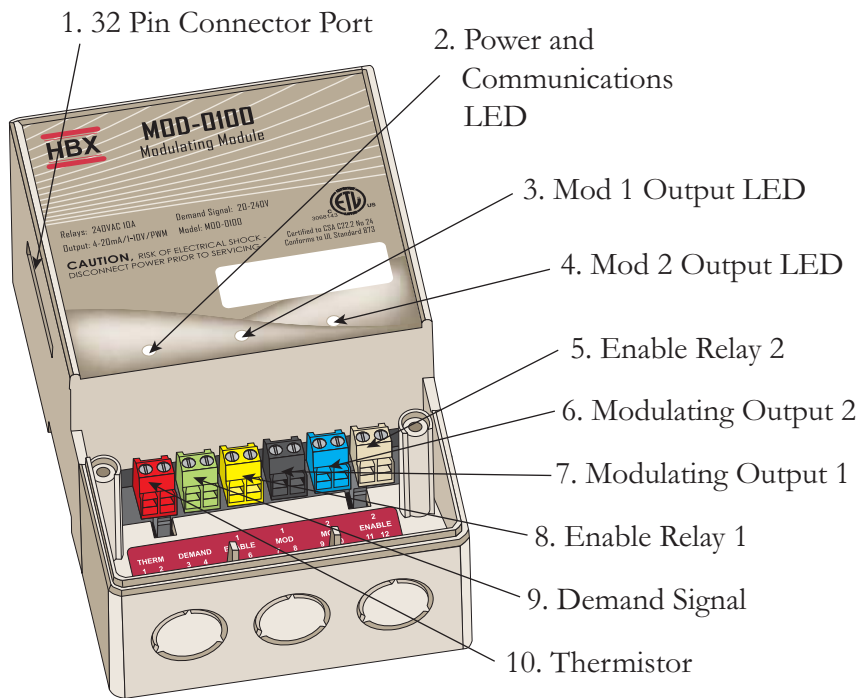

### Specifications:

1 x Thermistor Input (10K Ohm)

1 x Misc. Input Signal (20-240VAC)

2 x Enable. Output Relays (240VAC 10Amps)

2 x Mod Outputs (4-20mA, or 1-10v)

### Weight:

0.408Kg

### Dimensions:

100mm W x 170mm H x 70mm D

### ETL Listings:

Meets CSA C22.2 No. 24

Meets UL Standard 873

ETL Control No. 3068143

### Storage:

10°C to 40°C

## PHYSICAL DIMENSIONS

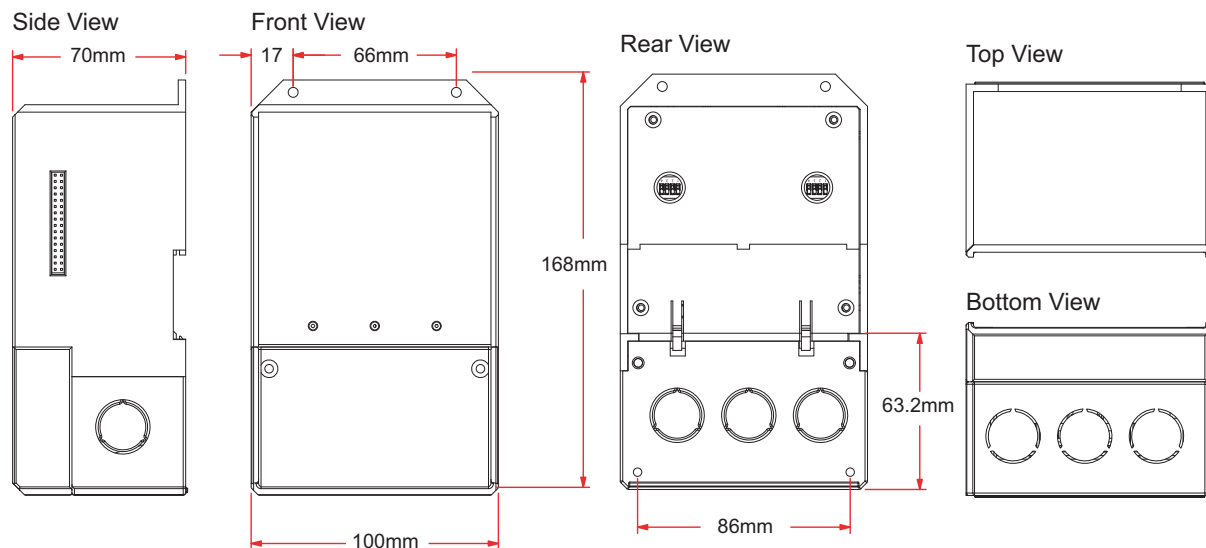

## DIP SWITCH SETTINGS

The MOD-0100 Module allows for two modulating boilers to be hooked up to the device. By changing the position on the dip switches an individual has the option to change the output signal. Dipswitches can be set to handle 1-10v, 4-20mA, or a combination of both.

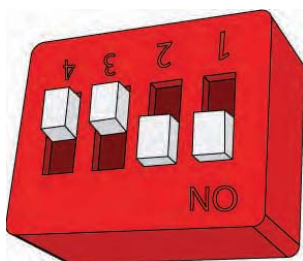
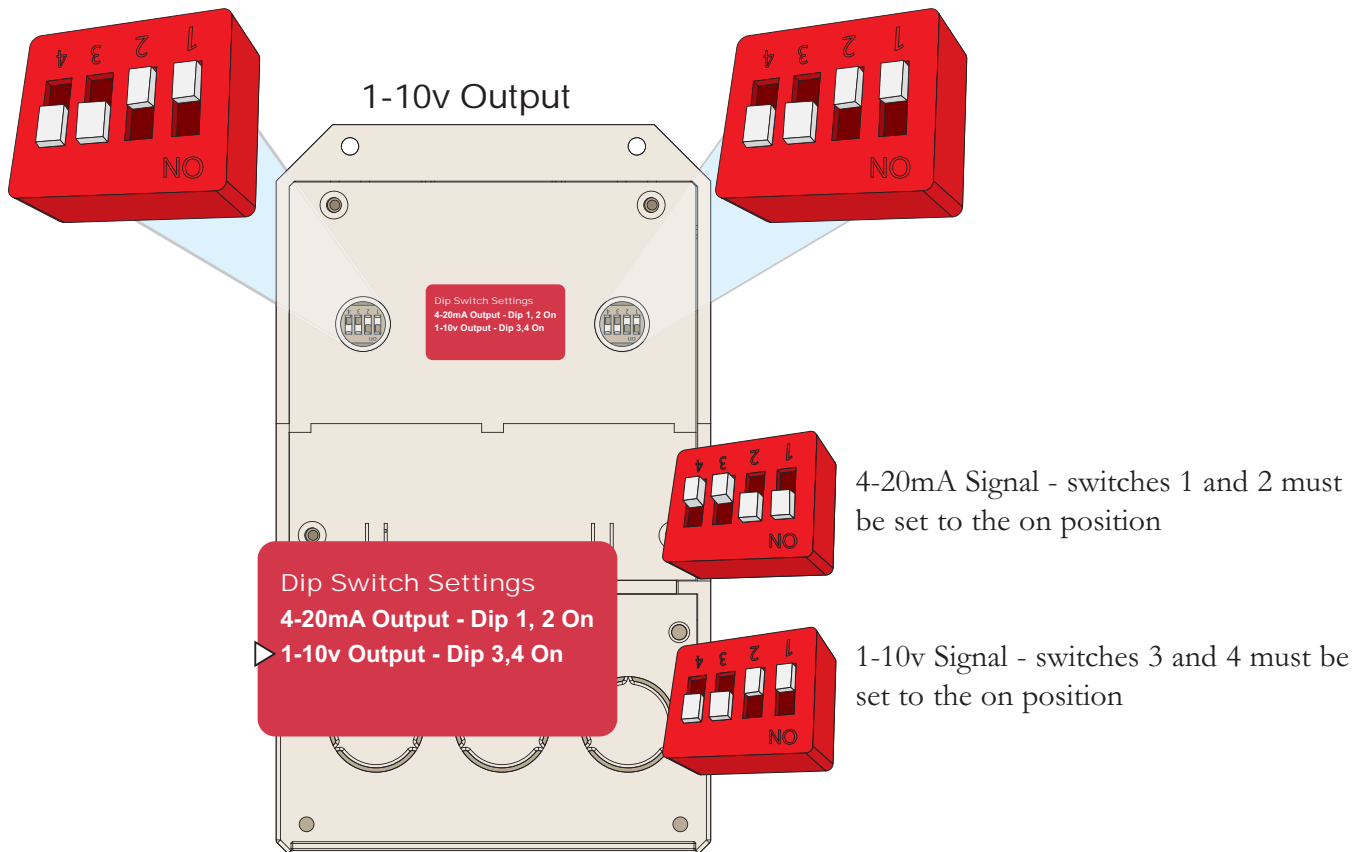

Switches sitting in the top position (closest to the numbers) are considered to be off. Switches sitting in the bottom position are considered to be on.

## MODULATION TYPE: SERIES

The Series method of modulating boilers is based on a simple but effective algorithm. Underlying theory causes boiler 1 to fire when there is a load; modulating from the start percent (designated by the installer within the modulating options of the Control) to 100%. If the heat demand has not been satisfied at this point boiler 2 will then begin to modulate from the start percent to 100% (if required). This process will continue for each installed modulating boiler in the system to a maximum of five.

The process of modulating the boilers off works the same. When the last boiler in the system drops to the start percent it will then shut off that

boiler. If the load continues to decrease then the Control will modulate down the second last boiler set up in the system. This will continue on until the lead boiler has dropped to the start percent. At this point the Control will allow the PID calculation to increase helping with boiler cycling. This will hold the lead boiler in the minimum fire (or start percent) position for longer, allowing the boiler to cycle less. As a result; system maintenance and system wear due to boiler cycling is decreased.

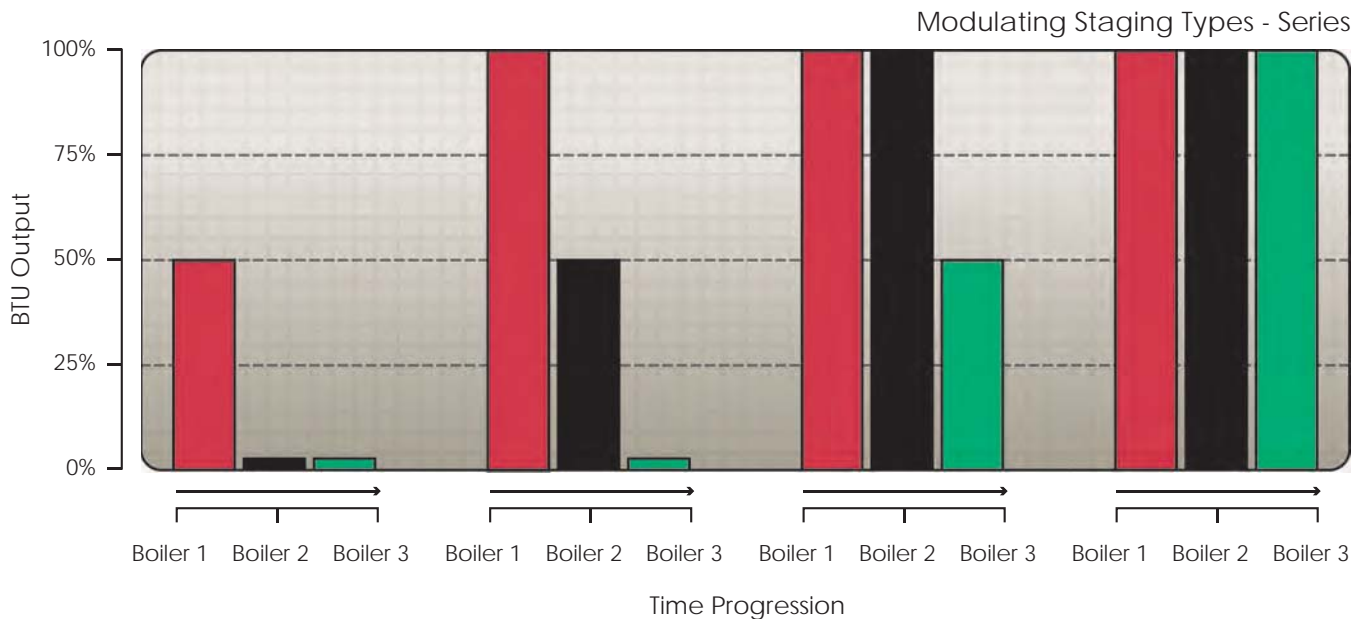

**MODULATION TYPE: PARALLEL**

The Parallel method of modulating boilers is the simplest of modulating algorithms. Underlying theory causes all of the installed boilers to simultaneously modulate from the start percent (designated by the installer within the modulating options of the Control) to 100% depending on the system load requirements. The maximum number of modulating boilers that the Control can handle is five.

The process of modulating the boilers off works in the same manner. When the load decreases, all of the boilers will modulate down until they are at the start percent. At this point, to help with boiler cycling, the Control will allow the PID calculation to increase. This will hold the lead boiler in the minimum fire position (or start percent) for longer allowing the modulating boiler to cycle less. As a result; system maintenance and system wear due to boiler cycling is decreased.

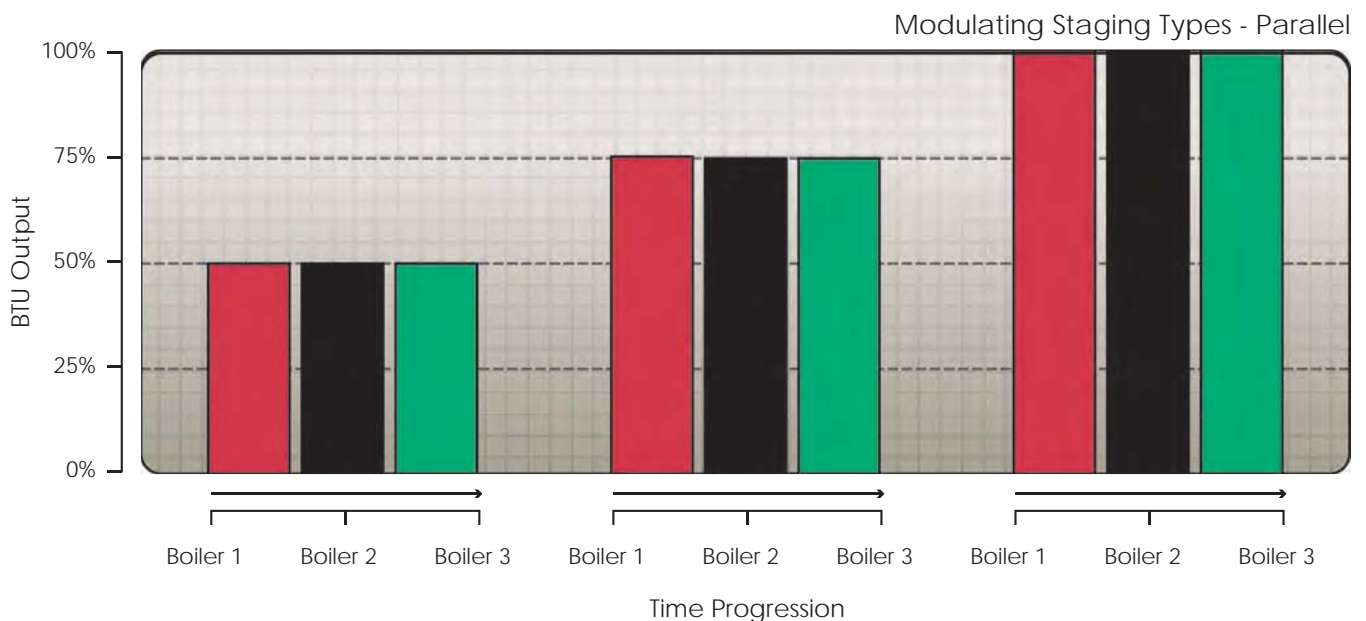



## MODULATION TYPE: PROGRESSIVE

Progressive modulation is a complex algorithm for very precise control over modulating devices. HBX Controls has optimized the process to work effectively for multiple modulating boilers. This modulation algorithm is a combination of series and parallel modulation with additional benefits.

Underlying theory causes the first boiler to modulate from the start percent (designated by the installer within the modulating options in of the Control) to 80% modulation. If the load still requires more heat then boiler 1 decreases to 40%, and boiler 2 increases from 0% to 40% (maintaining 80% output with 2 modulating boilers now on). As the load increases both modulating boiler 1 and modulating boiler 2 will increase to 80%. If there is still a higher load requirement, both boiler 1 and boiler 2 will decrease to 55% and modulating boiler 3 will

increase from 0% to 55%. All 3 modulating boilers now take on approximately the same load as the 2 modulating boilers at 80%. This process will continue on until all boilers set up in the system are firing. When all the modulating boilers are firing and a load is still required, all 3 boilers will modulate to 100% simultaneously.

As load decreases the modulating boilers will simultaneously modulate down to the start percent. The lag boiler will shut down and remaining modulating boilers will increase their modulating to split the remaining load in percent. At this point to help with boiler cycling the Control will allow the PID calculation to increase. This will hold the lead boiler in the minimum fire position for longer allowing the modulating boiler to cycle less. As a result; system maintenance and system wear due to boiler cycling is decreased.

Modulating Staging Types - Progressive

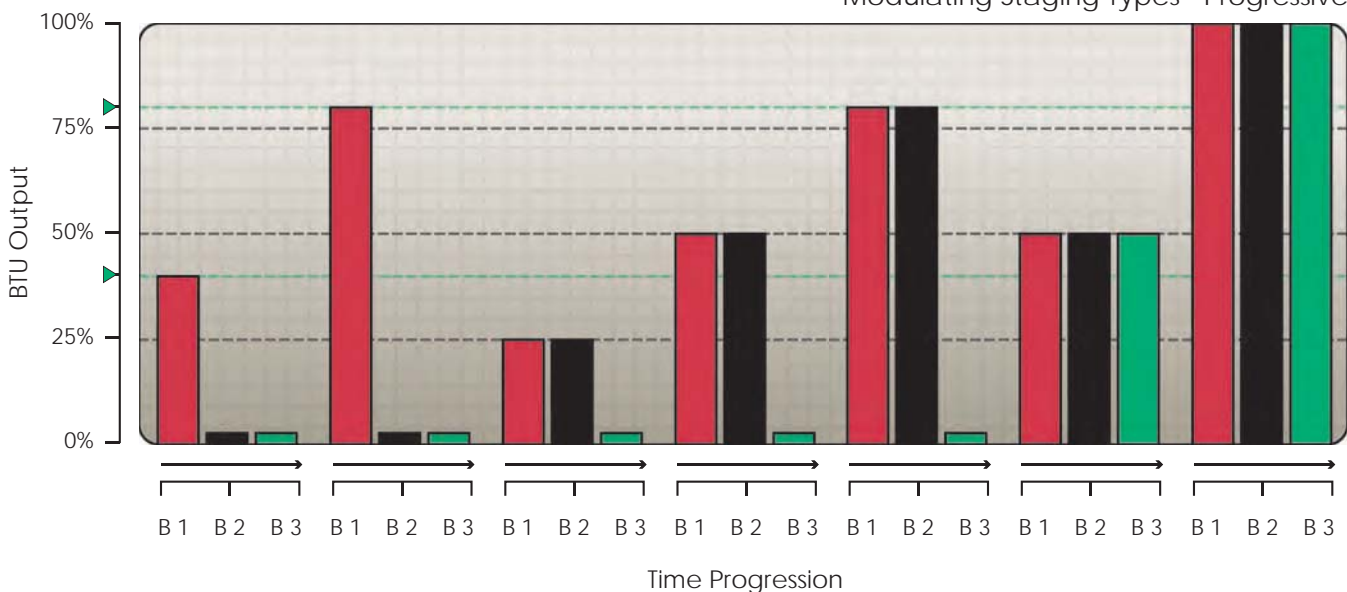

## MODULATING CONTROL MOD 1000-05

- The HBX MOD-0100 can be used to modulate a device that will control injection mixing. This option is available within the mixing options, only when the CPU-1000 is configured as a mixing or dual mixing control.

Note: Modulating is only available on the first mixing device in a dual mixing control.

### ELECTRICAL

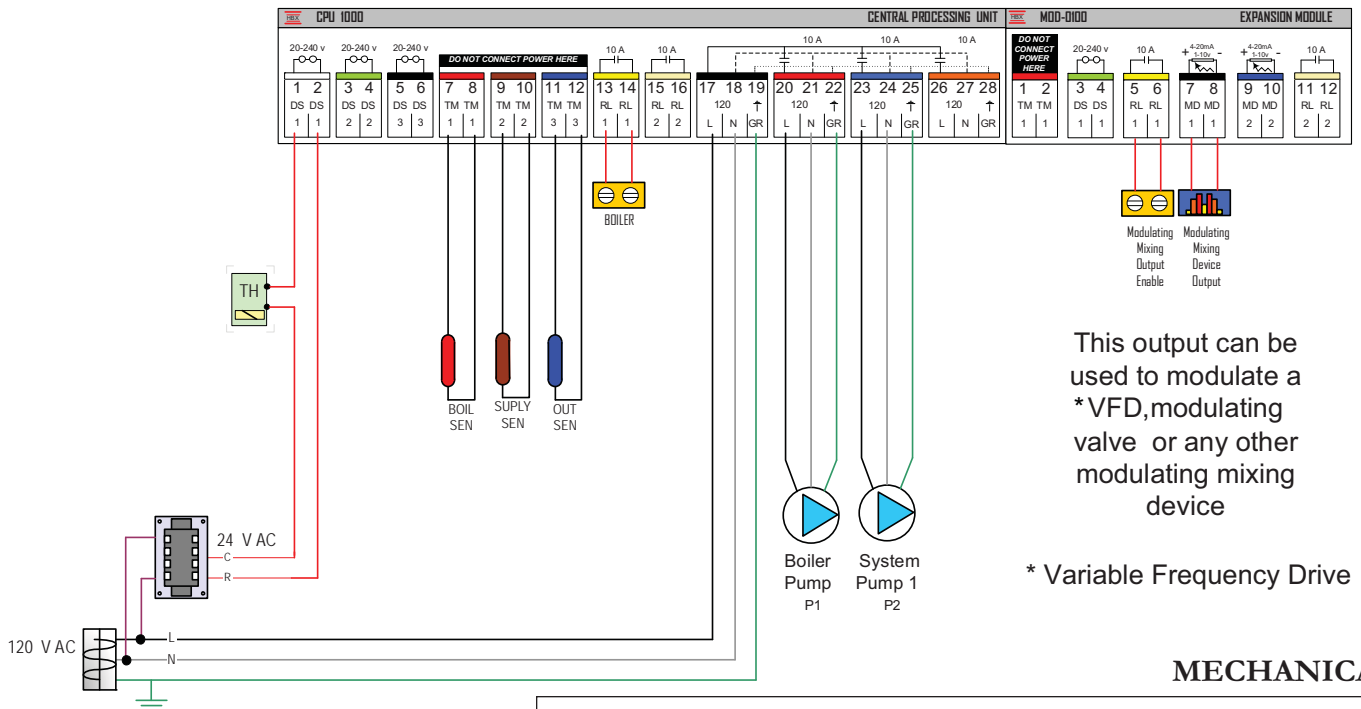

### MECHANICAL

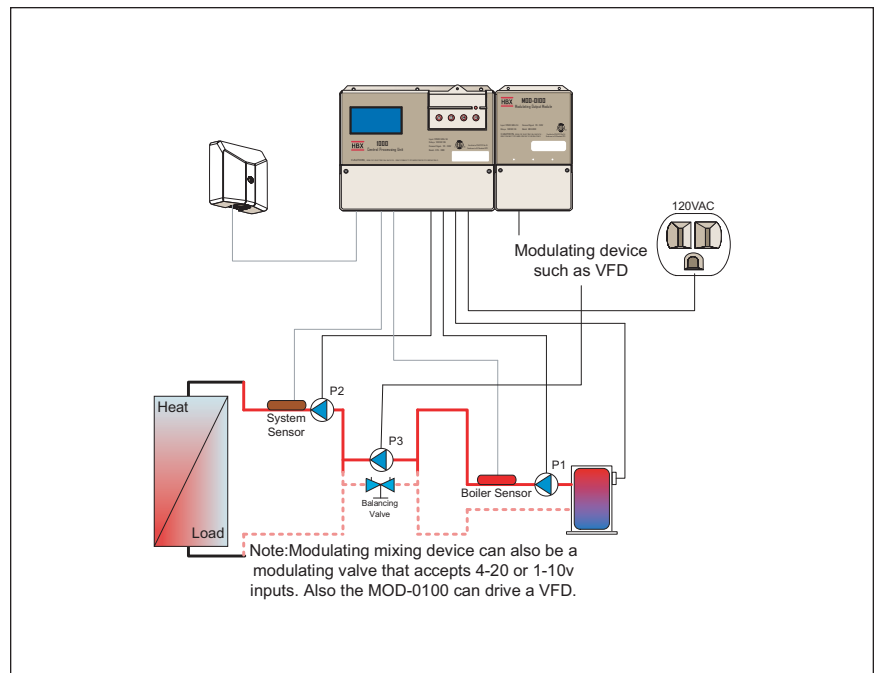

#### Pump Legend:

- P1 - Boiler Pump
- P2 - System Pump
- P3 - Injection Pump

## MODULATING CONTROL MOD 1000-01

- Single modulating boiler with one system pump.

### ELECTRICAL

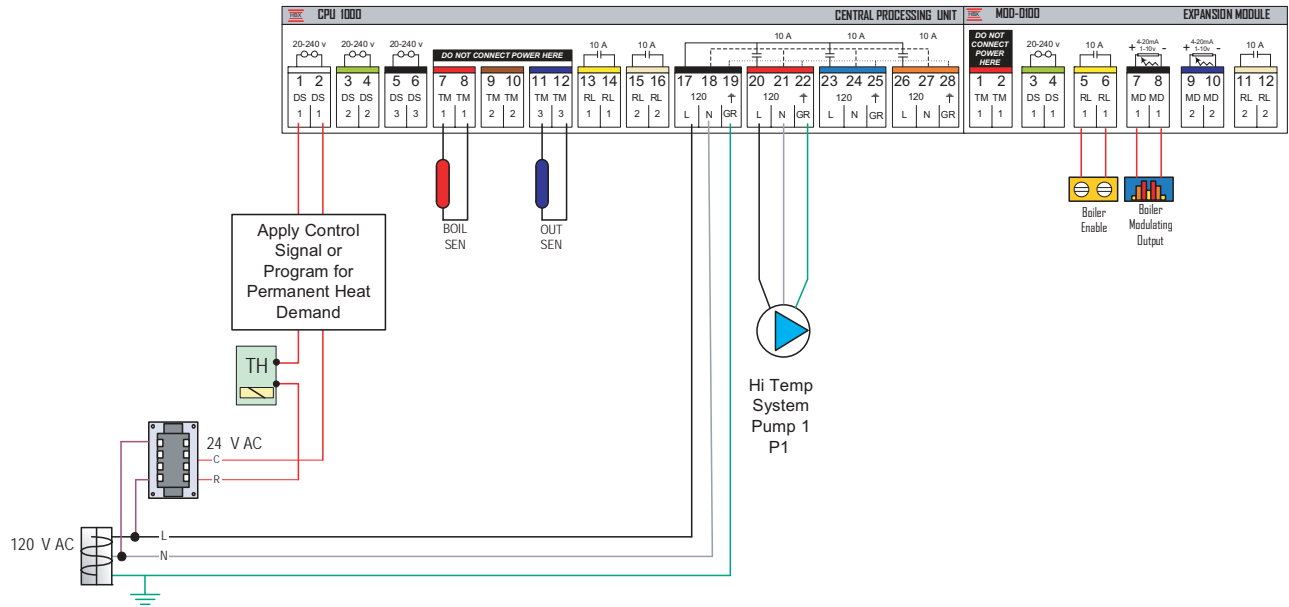

### MECHANICAL

#### Pump Legend:

- P1 - Hi Temp System Pump

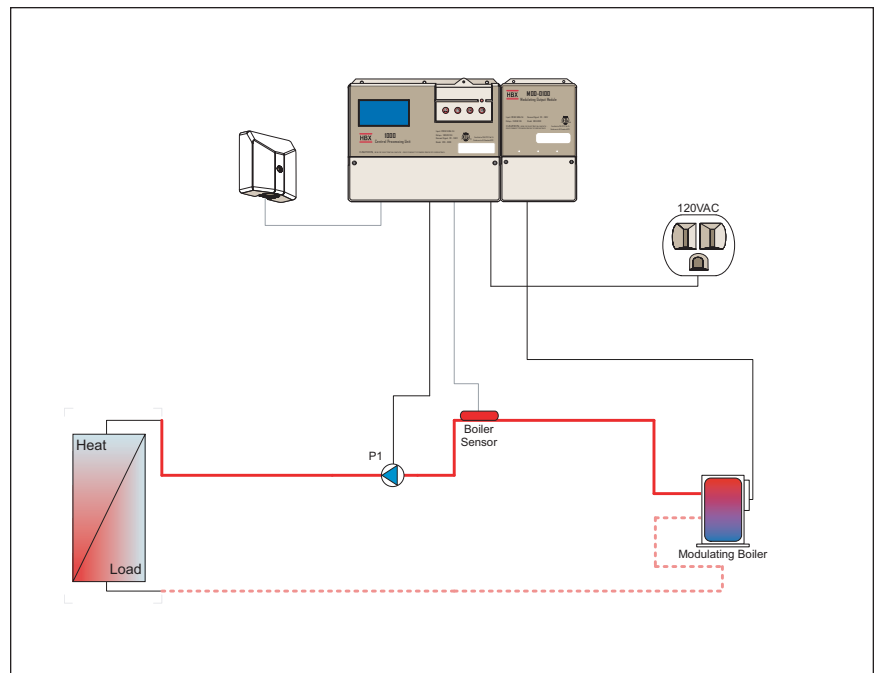

## MODULATING CONTROL MOD 1000-02

- Triple modulating boiler control with pump sequencer.
- Boiler pumps run from control.

### ELECTRICAL

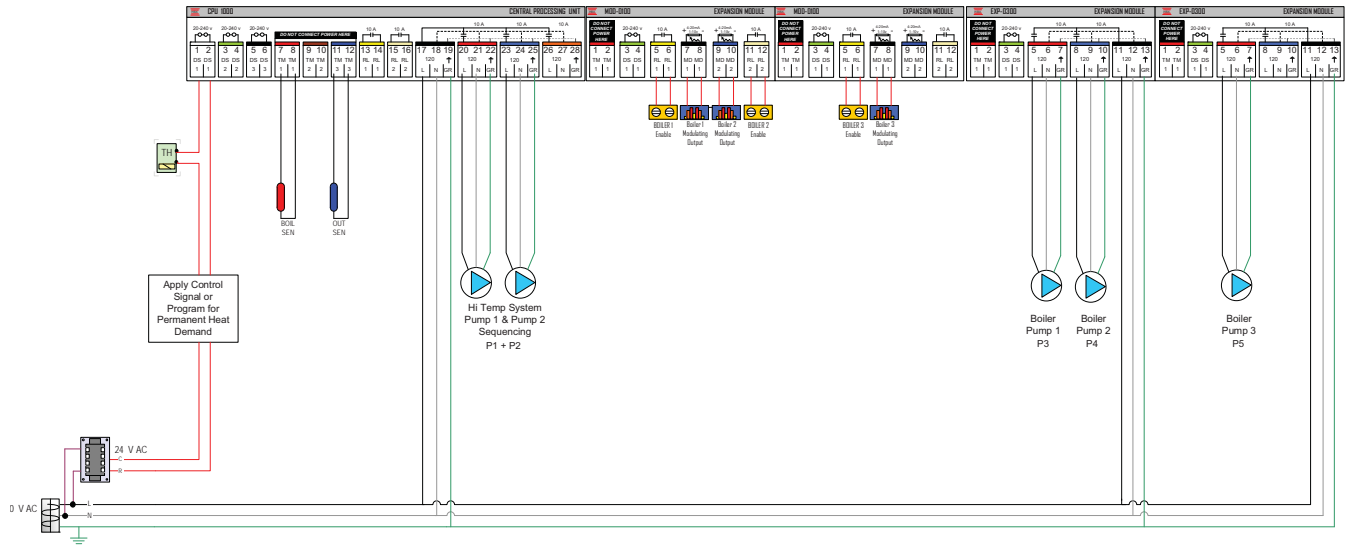

### MECHANICAL

#### Pump Legend:

- P1-P2 - Hi Temp System Pumps
- P3-P5 - Boiler Pumps

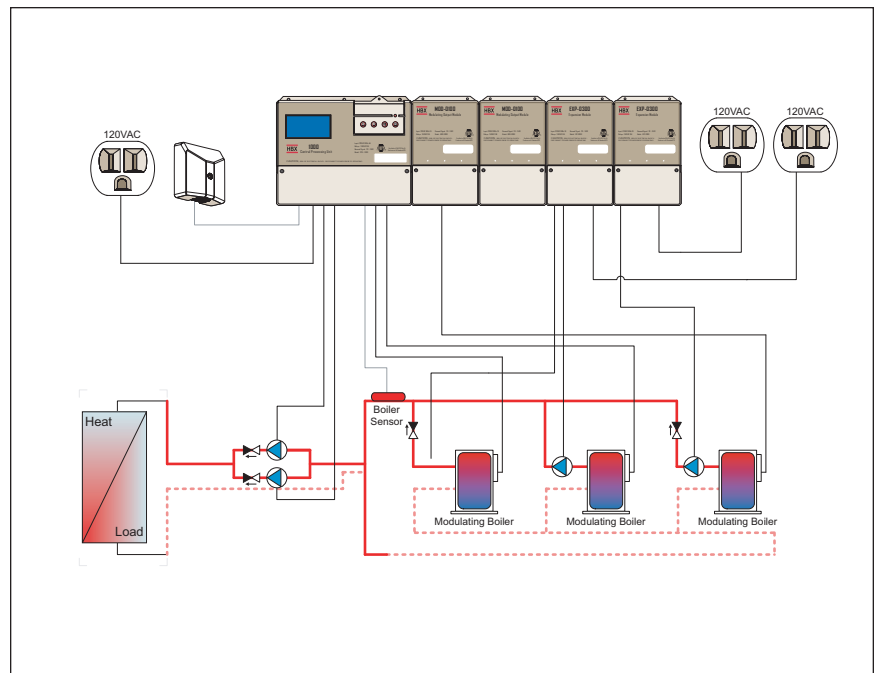

## MODULATING CONTROL MOD 1000-03

- Four modulating boiler control with pump sequencer.
- Running an indirect fire hot water tank.

## ELECTRICAL

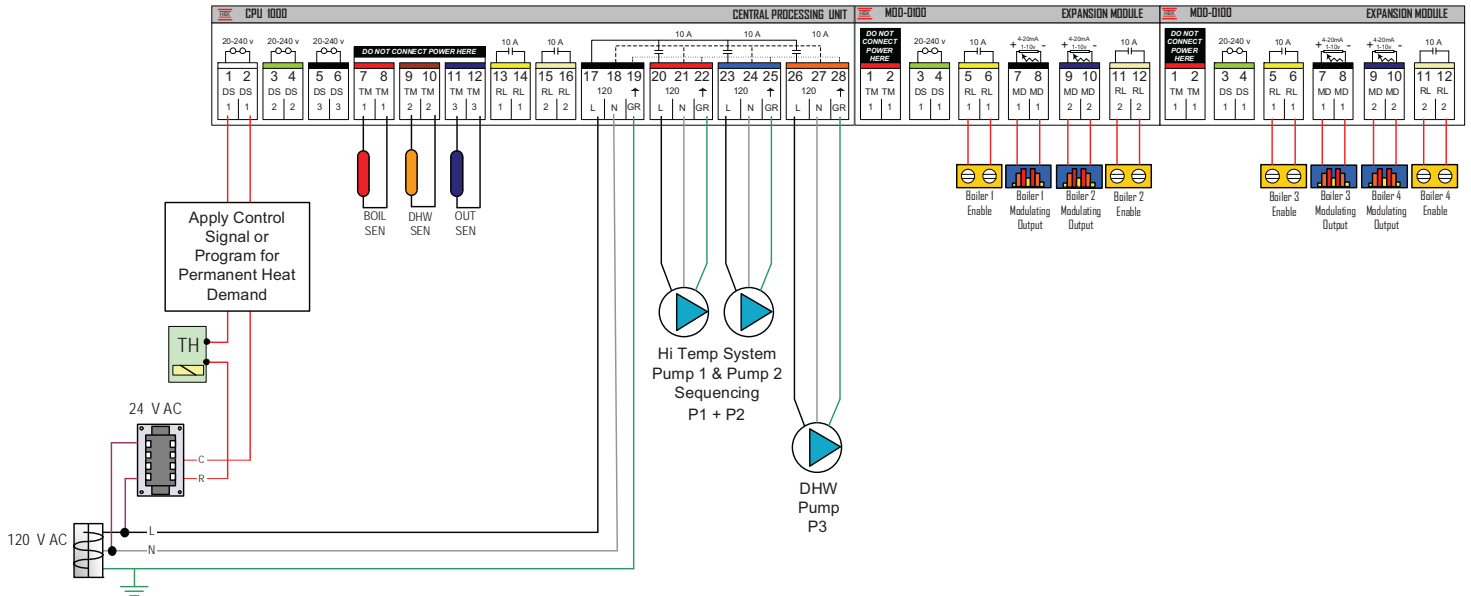

## MECHANICAL

### Pump Legend:

- P1-P2 - Hi Temp System Pumps
- P3 - DHW Pump

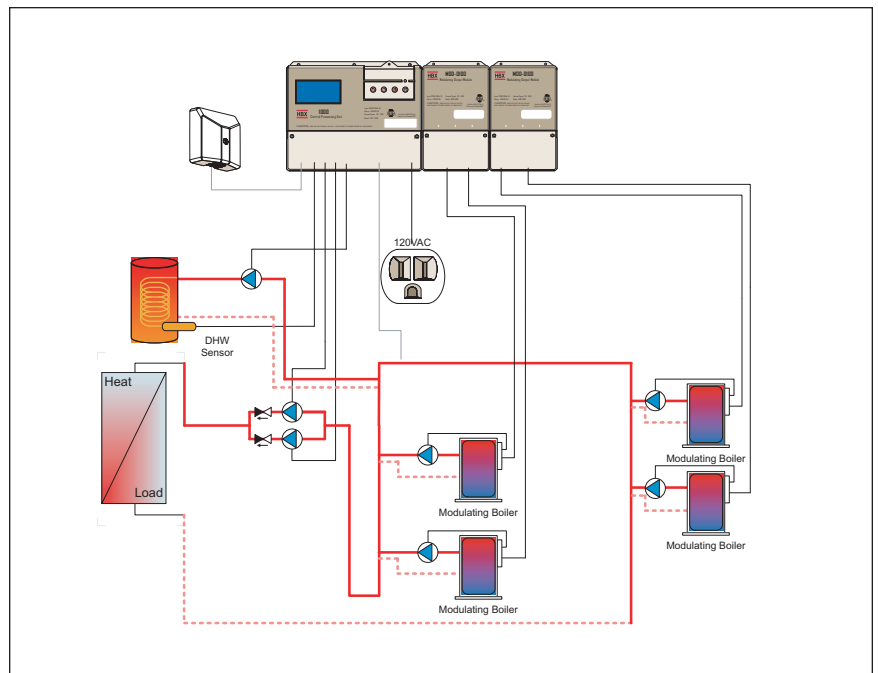

## MODULATING CONTROL MOD 1000-04

- Two modulating boiler control with two additional on/off boilers.
- Running pump sequencer and an indirect hot water tank.

### ELECTRICAL

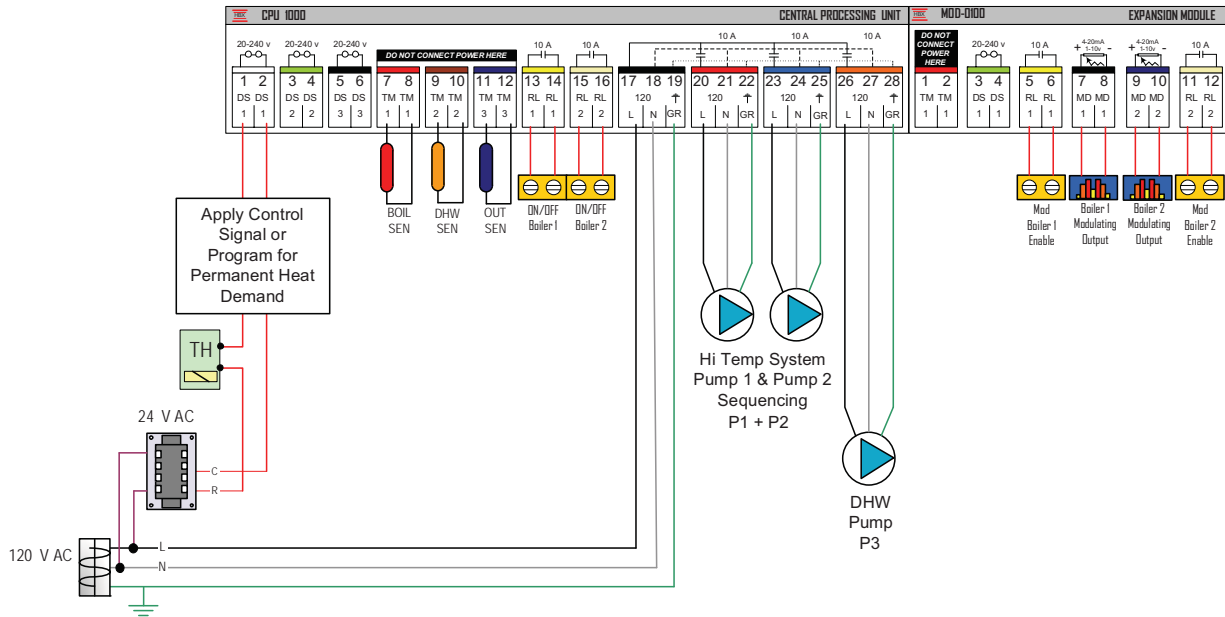

### MECHANICAL

#### Pump Legend:

- P1-P2 - Hi Temp System Pumps
- P3 - DHW Pump

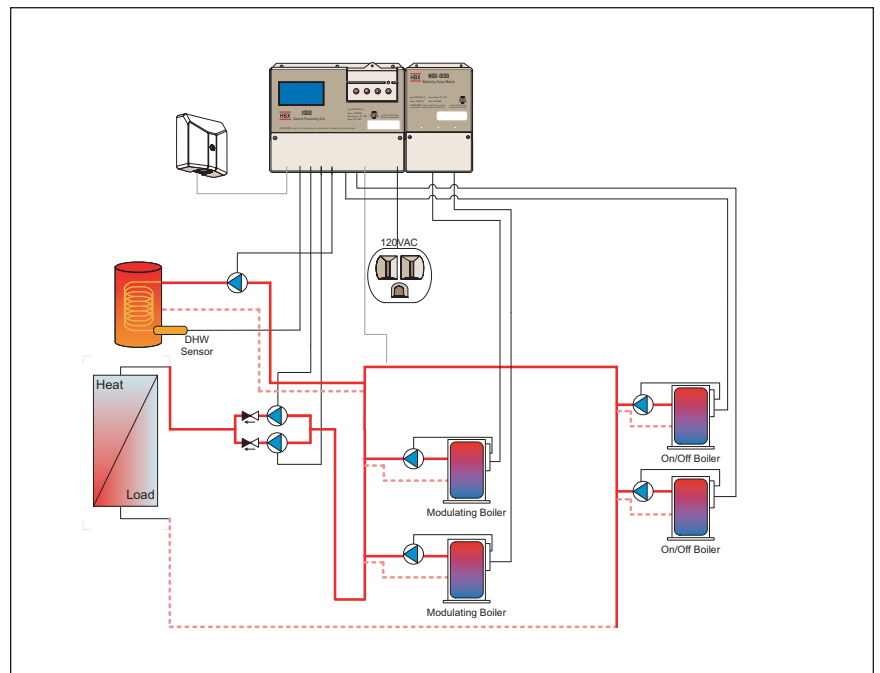

**Limited Warranty**

HBX Controls warrants each of its products to be free from defects in workmanship and materials under normal use and service for a period of 24 months from date of manufacture or 12 months from date of purchase from an HBX Authorized Dealer, if within the above documented period after date of manufacture.

If the product proves to be defective within the applicable warranty period, HBX on its sole discretion will repair or replace said product. Replacement product may be new or refurbished of equivalent or better specifications, relative to the defective product. Replacement product need not be of identical design or model. Any repair or replacement product pursuant to this warranty shall be warranted for not less than 90 days from date of such repair, irrespective of any earlier expiration of original warranty period. When HBX provides replacement, the defective product becomes the property of HBX Controls.

Warranty Service, within the applicable warranty period, may be obtained by contacting your nearest HBX Controls office via the original Authorized Agent and requesting a Return Material Authorization Number (RMA #). Proof of purchase in the form a dated invoice/receipt must be provided to expedite the issuance of a Factory RMA.

After an RMA number has been issued, the defective product must be packaged securely in the original or other suitable shipping package to ensure that it will not be damaged in transit. The RMA number must be visible on the outside of the package and a copy included inside the package. The package must be mailed or otherwise shipped back to HBX with all costs of mailing/shipping/insurance prepaid by the warranty claimant.

Any package/s returned to HBX without an approved and visible RMA number will be rejected and shipped back to purchaser at purchaser's expense. HBX reserves the right, if deemed necessary, to charge a reasonable levy for costs incurred, additional to mailing or shipping costs.

**Limitation of Warranties.**

If the HBX product does not operate as warranted above the purchaser's sole remedy shall be, at HBX's option, repair or replacement. The foregoing warranties and remedies are exclusive and in lieu of all other warranties, expressed or implied, either in fact or by operation of law, statutory or otherwise, including warranties of merchantability and fitness for a particular purpose/application. HBX neither assumes nor authorizes any other person to assume for it any other liability in connection with the sale, installation maintenance or use of HBX Controls products.

HBX shall not be liable under this warranty; if its testing and examination discloses that the alleged defect in the product does not exist or was caused by the purchaser or third persons misuse, neglect, improper installation or testing, unauthorized attempts to repair or any other cause beyond the range of intended use, or by accident, fire, lightning or other hazard.

**Limitation of Liability.**

In no event will HBX be liable for any damages, including loss of data, loss of profits, costs of cover or other incidental, consequential or indirect damages arising out of the installation, maintenance, commissioning, performance, failure or interruption of an HBX product, however caused and on any theory of liability. This limitation will apply even if HBX has been advised of the possibility of such damage.

**Local Law.**

This limited warranty statement gives the purchaser specific legal rights. The purchaser may also have other rights, which vary from state to state in the United States, from Province to Province in Canada and from Country to Country elsewhere in the world.

To the extent this Limited Warranty Statement is inconsistent with local law, this statement shall be deemed modified to be consistent with such local law. Under such local law, certain disclaimers and limitations of this statement may not apply to the purchaser. For example, some states in the United States, as well as some governments outside the United States (including Canadian Provinces), may:

Preclude the disclaimers and limitations in this statement from limiting the statutory rights of a consumer (e.g. United Kingdom);

Otherwise restrict the ability of a manufacturer to enforce such disclaimers or limitations; or

Grant the purchaser additional warranty rights which the manufacturer cannot disclaim, or not allow limitations on the duration of implied warranties.

Phone: +1 (403) 720-0029 Fax: +1 (403) 720-0054  
Email: [info@hbxcontrols.com](mailto:info@hbxcontrols.com) Web: [www.hbxcontrols.com](http://www.hbxcontrols.com)

v3.1

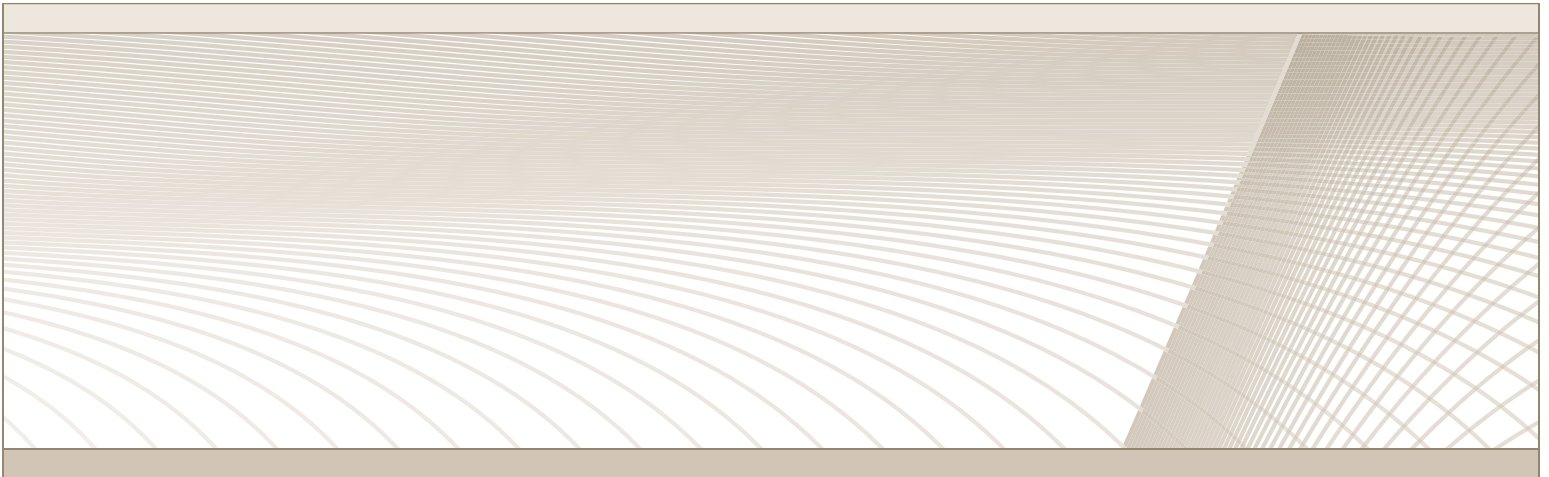

HBX Control Systems Inc.  
4516 - 112<sup>th</sup> Avenue SE  
Calgary, AB Canada T2C 2K2

© HBX Control Systems Inc. 2011