

Installation Manual
ORC-0100
Version 1.0



HBX

ORC-0100

HBX Control Systems Inc.

TABLE OF CONTENTS

Introduction	Index
Safety Symbols and Warnings	Index
Receipt and Inspection	1
Description	1
Technical Data and Dimensions	1
Programming ORC-0100	2 - 3
- Navigating the ORC-0100	2
- Boiler Adjustments	2-3
Connection and Wiring	4-7
Connections	4
Wiring Diagrams	4-7
Limited Warranty	9

INTRODUCTION

This manual will help with the installation, parameter setting, troubleshooting and general maintenance requirements for the Controller. To guarantee the safe and reliable operation of this Control, you must first read this manual in detail and take particular note to any and all warnings or caution directives prior to connecting to AC power.

Only suitably qualified individuals with formal training in electrical and HVAC controls should attempt the installation of this equipment. Incorrect wiring and installation will affect the warranty provided with this unit. Wiring must be completed in accordance with the codes and practices applicable to the jurisdiction for the actual installation.



SAFETY SYMBOLS AND WARNINGS

DRAWING REFERENCE

Refer to the specified electrical drawing at the back of the manual.



PRECAUTION

A measure taken in advance to prevent dangerous or an unpleasant event

RECEIPT & INSPECTION

After receiving, inspect the unit for any possible physical damage that may have occurred during transportation. After unpacking the unit make sure the box contains:

- 1 x Universal sensor
- 1 x Outdoor reset control ORC-0100
- 1 x Outdoor Sensor
- 1 x Screwdriver
- Instruction Manual

DESCRIPTION

The HBX ORC-0100 is designed to be an energy-saving automatic control for hot water boilers. The ORC-0100 measures the outside air temperature and re-adjust the heating system water to a minimum water temperature to satisfy the heat loss of the home or building.

Some features of the ORC-0100 are:

- Backlit graphic display
- Push button keypad control
- User-friendly programming features
- Includes external sensor
- Integrated 2 Amp dry contacts

TECHNICAL DATA AND DIMENSIONS

Technical Data

3 x Contact Output
(120VAC 2 Amp Max)
2 x External Thermistor Input
1 x Power Contact: 24VAC

Dimensions: 115 x 80 x 27.5mm

ETL Listings:

Meets CSA C22.2 No. 24
Meets UL Standard 873
ETL Control No. 3068143

Storage: +10C to +40C

Languages: English

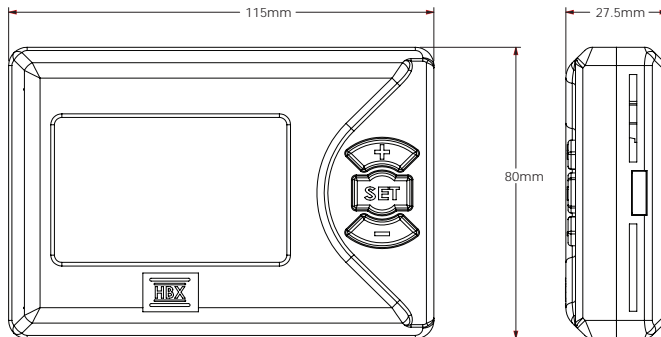

PROGRAMMING ORC-0100

NAVIGATING THE OUTDOOR RESET CONTROL

All programming steps within the outdoor reset control are achieved by using the three buttons (and combinations thereof) located on the right-hand side of the thermostat.

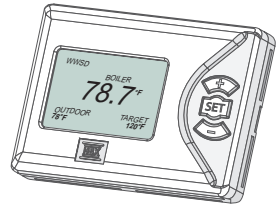

The + button is used to scroll up in menu screens and increase a value within specific options.



The - button is used to scroll down in menu screens and decrease a value within specific options.

BOILER ADJUSTMENT SCREEN

Holding down the **set** button for 2 seconds while viewing the “Status Screen” will take you into the “Adjustment Screen”.



Once you are in the desired options screen, use the + and - button to scroll up and down. Press down the **set** button to choose the option (the arrow to the left of your chosen option will turn black when you have selected a specific step), then the + and - buttons to adjust the value.

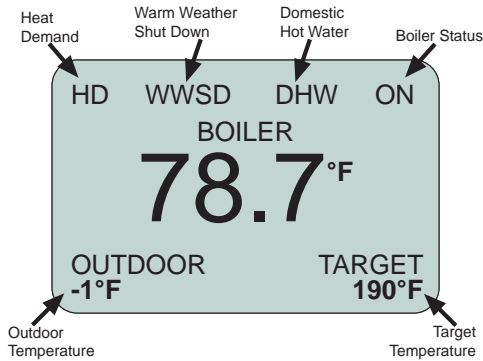

SPECIAL FEATURES

1) System pump pre-purge (30 seconds)

This will allow any residual heat to be taken out of the boiler before firing the boiler. This feature is designed to reduce short cycling.

2) System Pump Post Purge (60 seconds)

After the heat demand has gone away the system pump will stay on for 60 seconds. This will reduce a spike in temperature in the boiler when the demand goes away.

3) DHW Priority (60 minutes)

This allows the user to select whether they would like the main system pump to go off if there is a DHW demand. If priority is yes when there is a DHW call and WWSD is on, the system pump will not come on.

BOILER ADJUSTMENTS

- ▷ 1) MAX BOILER 190°F
- 2) MIN BOILER 120°F
- 3) OUT DESIGN -10°F
- 4) DIFF 10°F
- 5) WWSD 72°F
- 6) DHW PRTY OFF

Maximum Boiler Temperature

"Maximum Boiler Temperature" is used in the outdoor reset design calculation, and also serves as the maximum setting for the boiler.

BOILER ADJUSTMENTS

- 1) MAX BOILER 190°F
- ▷ 2) MIN BOILER 120°F
- 3) OUT DESIGN -10°F
- 4) DIFF 10°F
- 5) WWSD 72°F
- 6) DHW PRTY OFF

Minimum Boiler Temperature

Reduces the risk of condensing flue gases. It can run with both condensing, and non-condensing boilers. Setup as per boiler manufacturers recommendation.



Refer to diagram #4 Outdoor Reset Curve

BOILER ADJUSTMENTS

- 1) MAX BOILER 190°F
- 2) MIN BOILER 120°F
- ▷ 3) OUT DESIGN -10°F
- 4) DIFF 10°F
- 5) WWSD 72°F
- 6) DHW PRTY OFF

Outdoor Design Temperature

The "Outdoor Design Temperature" option should be set to reflect your specific city or region. It factors into the outdoor reset curve calculation.



Refer to diagram #4 Outdoor Reset Curve

BOILER ADJUSTMENTS

- 1) MAX BOILER 190°F
- 2) MIN BOILER 120°F
- 3) OUT DESIGN -10°F
- ▷ 4) DIFF 10°F
- 5) WWSD 72°F
- 6) DHW PRTY OFF

Differential

A differential of 10° is 5° above setpoint and 5° below setpoint. *Range from 2°F to 60°F.*

BOILER ADJUSTMENTS

- 1) MAX BOILER 190°F
- 2) MIN BOILER 120°F
- 3) OUT DESIGN -10°F
- 4) DIFF 10°F
- ▷ 5) WWSD 72°F
- 6) DHW PRTY OFF

Warm Weather Shutdown

"Warm Weather Shutdown" is the outdoor temperature that must be reached for the control to enter an energy-saving hibernation mode.

BOILER ADJUSTMENTS

- 1) MAX BOILER 190°F
- 2) MIN BOILER 120°F
- 3) OUT DESIGN -10°F
- 4) DIFF 10°F
- 5) WWSD 72°F
- ▷ 6) DHW PRTY OFF

Domestic Hot Water Priority

This option will allow the DHW demand to override the heating system for a max of 60mins in order to satisfy the DHW demand. Once the control switches to DHW priority, the DHW target will be the Maximum Boiler Temperature. If after the 60mins there is still an unsatisfied heat demand, the ORC-0100 will automatically switch the system pump back on to accommodate the call for heat. Once the control switches to heat mode, the heat target will be calculated based on the actual outside temperature.

CONNECTIONS AND WIRING DIAGRAMS

CONNECTIONS

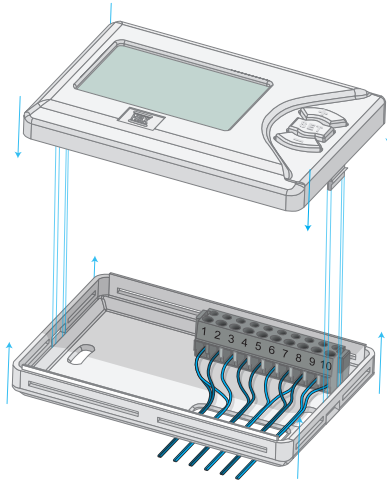

WIRING DIAGRAMS

#1. PERMANENT HEAT DEMAND

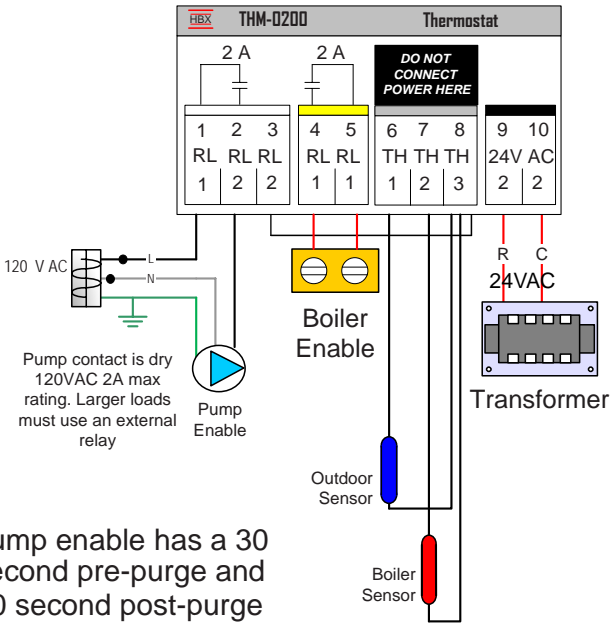

Pump enable has a 30 second pre-purge and 60 second post-purge

#2. DOMESTIC HOT WATER

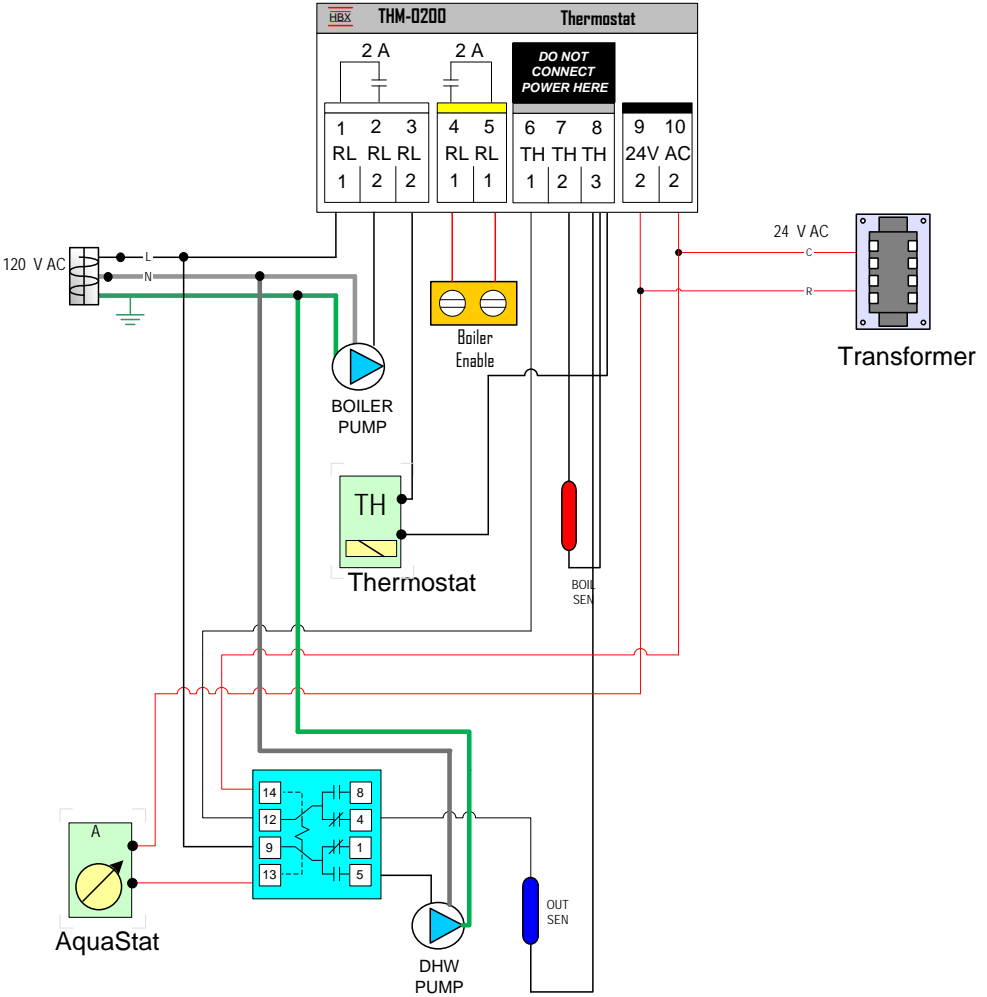

#3. EXTERNAL THERMOSTAT

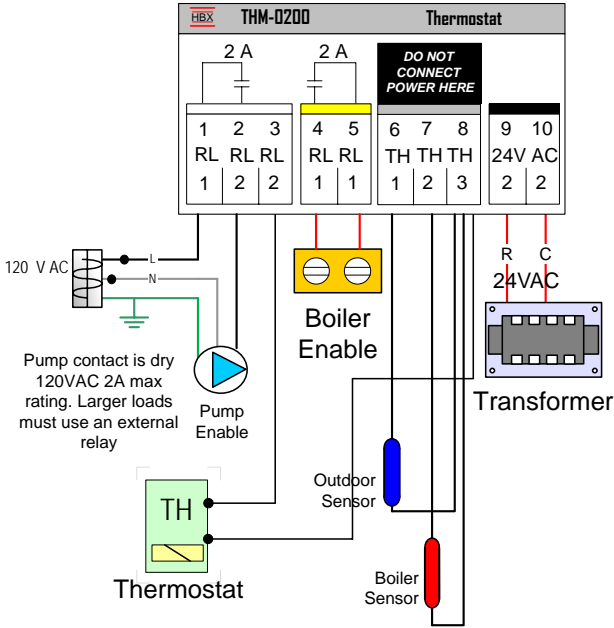

Pump enable has a 30 second pre-purge and 60 second post-purge

#4. OUTDOOR RESET CURVE

The boiler temperature will reach this temperature when the outdoor temperature is equal to or lower than the design outdoor temperature

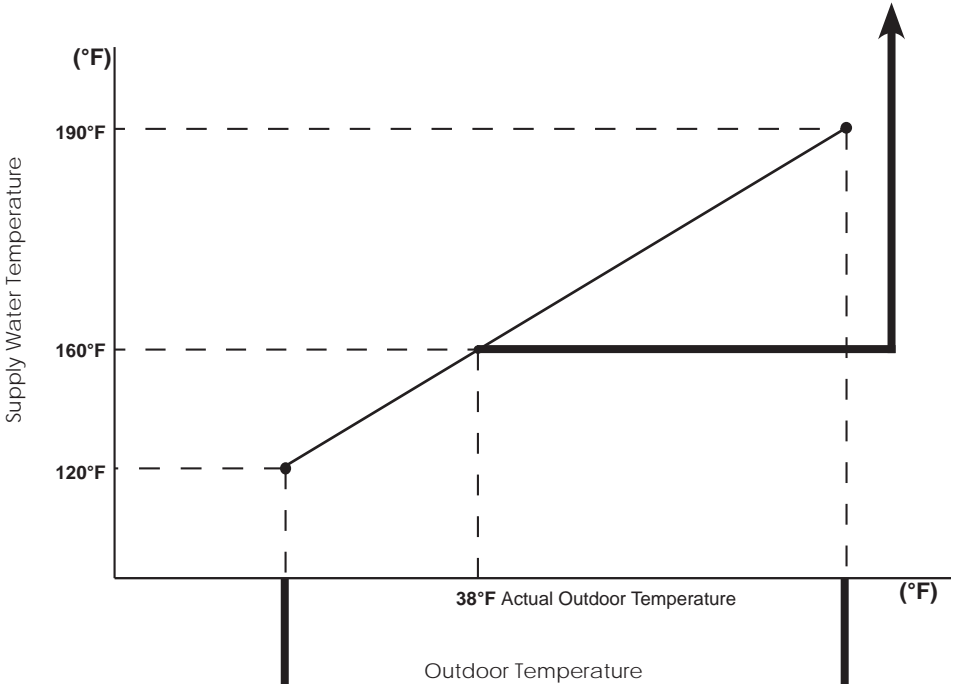
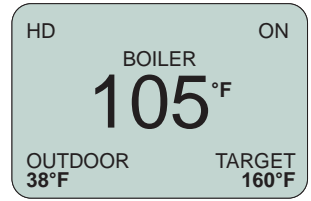

BOILER ADJUSTMENTS	
1) MAX BOILER	190°F
D 2) MIN BOILER	120°F
3) OUT DESIGN	-10°F
4) DIFF	10°F
5) WWSD	72°F
6) DHW PRTY	OFF

BOILER ADJUSTMENTS	
D 1) MAX BOILER	190°F
2) MIN BOILER	120°F
3) OUT DESIGN	-10°F
4) DIFF	10°F
5) WWSD	72°F
6) DHW PRTY	OFF

NOTES

LIMITED WARRANTY

HBX Controls warrants each of its products to be free from defects in workmanship and materials under normal use and service for a period of 24 months from date of manufacture or 12 months from date of purchase from an HBX Authorized Dealer, if within the above documented period after date of manufacture.

If the product proves to be defective within the applicable warranty period, HBX on its sole discretion will repair or replace said product. Replacement product may be new or refurbished of equivalent or better specifications, relative to the defective product. Replacement product need not be of identical design or model. Any repair or replacement product pursuant to this warranty shall be warranted for not less than 90 days from date of such repair, irrespective of any earlier expiration of original warranty period. When HBX provides replacement, the defective product becomes the property of HBX Controls.

Warranty Service, within the applicable warranty period, may be obtained by contacting your nearest HBX Controls office via the original Authorized Agent and requesting a Return Material Authorization Number (RMA #). Proof of purchase in the form of a dated invoice/receipt must be provided to expedite the issuance of a Factory RMA.

After an RMA number has been issued, the defective product must be packaged securely in the original or other suitable shipping package to ensure that it will not be damaged in transit. The RMA number must be visible on the outside of the package and a copy included inside the package. The package must be mailed or otherwise shipped back to HBX with all costs of mailing/shipping/insurance prepaid by the warranty claimant.

Any package/s returned to HBX without an approved and visible RMA number will be rejected and shipped back to purchaser at purchaser's expense. HBX reserves the right, if deemed necessary, to charge a reasonable levy for costs incurred, additional to mailing or shipping costs.

LIMITATION OF WARRANTIES

If the HBX product does not operate as warranted above the purchasers sole remedy shall be, at HBX's option, repair or replacement. The foregoing warranties and remedies are exclusive and in lieu of all other warranties, expressed or implied, either in fact or by operation of law, statutory or otherwise, including warranties of merchantability and fitness for a particular purpose/application. HBX neither assumes nor authorizes any other person to assume for it any other liability in connection with the sale, installation maintenance or use of HBX Controls products.

HBX shall not be liable under this warranty; if its testing and examination discloses that the alleged defect in the product does not exist or was caused by the purchasers or third persons misuse, neglect, improper installation or testing, unauthorized attempts to repair or any other cause beyond the range of intended use, or by accident, fire, lightning or other hazard.

LIMITATION OF LIABILITY

In no event will HBX be liable for any damages, including loss of data, loss of profits, costs of cover or other incidental, consequential or indirect damages arising out of the installation, maintenance, commissioning, performance, failure or interruption of an HBX product, however caused and on any theory of liability. This limitation will apply even if HBX has been advised of the possibility of such damage.

LOCAL LAW

This limited warranty statement gives the purchaser specific legal rights. The purchaser may also have other rights which vary from state to state in the United States, from Province to Province in Canada and from Country to Country elsewhere in the world.

To the extent this Limited Warranty Statement is inconsistent with local law, this statement shall be deemed modified to be consistent with such local law. Under such local law, certain disclaimers and limitations of this statement may not apply to the purchaser. For example, some states in the United States, as well as some governments outside the United States (including Canadian Provinces), may: Preclude the disclaimers and limitations in this statement from limiting the statutory rights of a consumer (e.g. United Kingdom);

Otherwise restrict the ability of a manufacturer to enforce such disclaimers or limitations; or grant the purchaser additional warranty rights which the manufacturer cannot disclaim, or not allow limitations on the duration of implied warranties.

Phone: +1 (403) 720-0029 Fax: +1 (403) 720-0054
Email: info@hbxcontrols.com Web: www.hbxcontrols.com

V1.0

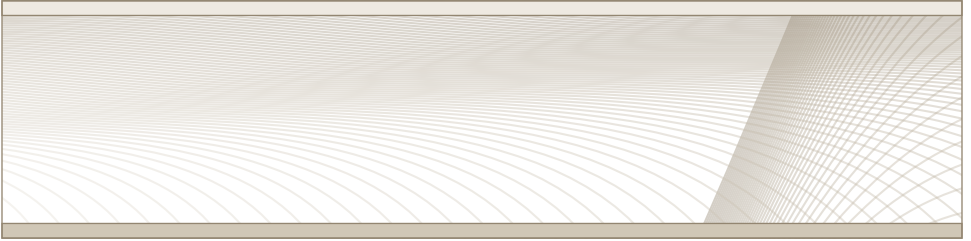

HBX Control Systems Inc.
4516 - 112th Avenue SE
Calgary, AB Canada T2C 2K2

© HBX Control Systems Inc. 2012