

Submittal: HBX SNO-0550

Project:[]

HBX Controls Inc Specification

Part 1: SNO-0550 Product

1. The Control must be capable of utilizing a multi-color backlight display.
2. The Hydronic Control must be a full microprocessor control with at least an 8-bit, 8MHz integrated microprocessor chip.
3. The Control must be capable of the following Input/Output Functions
 - a. 1 x Demand Input/Dry contacts
 - b. 1 x Boiler/BMS Output Relay
 - c. 4 x Temperature Sensor Inputs:
 - i. System
 - ii. Return
 - iii. Slab Sensor
 - iv. Outdoor Air Temperature
 - d. 3 x Output Relay (Pumps or Valve)
 - e. 1 x Optical (digital) Snow sensor input
4. The Control must be capable of automatically calculating and resetting the system fluid target temperature based on the user defined system delta T for slab protection.
5. The Control must have the ability to program and control for Warm Weather Shut Down, and Cold Weather Shut Down.
6. The Control must be capable of operating a PMIP injection pump or a floating action valve for mixing purposes.
7. The Control/unit must operate using a three button user interface
8. The Control must also be capable of utilizing feedback from optical snow sensing technology with integrated slab temperature sensing.

9. The Control must have adjustable preset snow conditions to allow for snow and ice detector tuning.
10. The Control must have onboard testing capabilities to individually test each relay and to test control operations functionality.
11. The Control unit must be ETL approved.

Part 2: Acceptable Products

1. HBX SNO-0550 Control

Part 3: Physical Dimensions

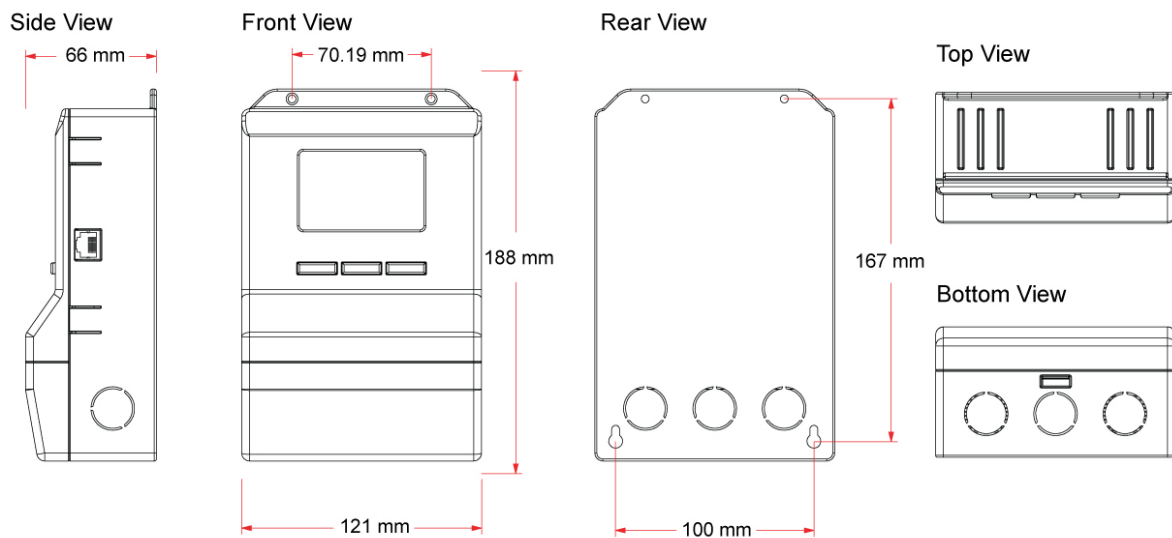

Part 4: Technical Data, Main Parts & Labels

Inputs/Outputs:

3 x Thermistor Input (10K Ohm)
1 x Boiler/BMS Dry Contact (120 VAC, 2A) Output
3 x Relay Dry Contact (240VAC, 5A) Outputs
1 x Dry Contact Demand Input

Sensor Input:

1 x Optical Snow & Ice Detector / Slab Sensor Input
1 x Modulating Heater Output

Power supply:

120 VAC, 15A (protected by resettable fuse)

Supplied Parts:

1 x HBX 029-0022 – 10K Ohm Thermistor, 12” lead wire
1 x HBX OUT-0100 – 10K Ohm Outdoor Sensor

Dimensions:

4.76” x 7.40” x 2.60” (121mm x 188mm x 66mm)

ETL Listings:

Meets CSA C22.2 No. 24
Meets UL Standard 873
ETL Control No. 3068143

Storage:

50°F to 104°F (10°C to 40°C)

Terminal Block Labels:

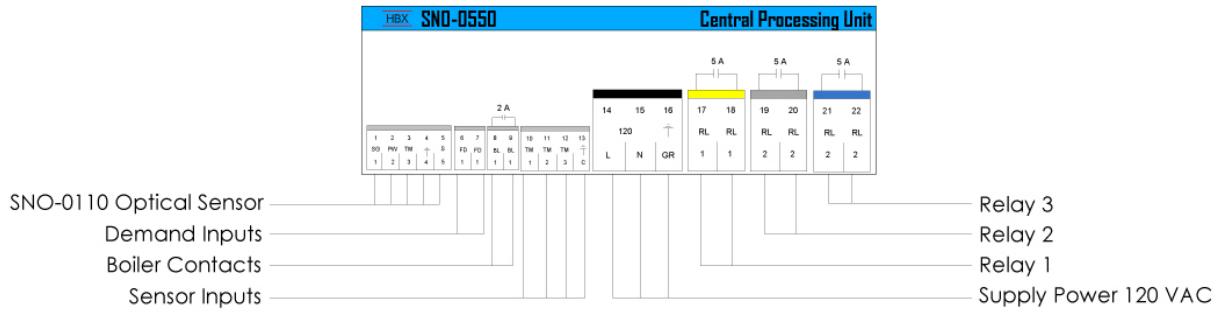

Part 5: HBX Sensor Temperature Conversion / Resistance Table

Celsius	Fahrenheit	Ohms	Celsius	Fahrenheit	Ohms	Celsius	Fahrenheit	Ohms
-30	-22	177,000	15	59	15,714	60	140	2,488
-29	-20.2	166,342	16	60.8	15,000	61	141.8	2,400
-28	-18.4	156,404	17	62.6	14,323	62	143.6	2,315
-27	-16.6	147,134	18	64.4	13,681	63	145.4	2,235
-26	-14.8	138,482	19	66.2	13,071	64	147.2	2,157
-25	-13	130,402	20	68	12,493	65	149	2,083
-24	-11.2	122,807	21	69.8	11,942	66	150.8	2,011
-23	-9.4	115,710	22	71.6	11,418	67	152.6	1,943
-22	-7.6	109,075	23	73.4	10,921	68	154.4	1,876
-21	-5.8	102,868	24	75.2	10,449	69	156.2	1,813
-20	-4	97,060	25	77	10,000	70	158	1,752
-19	-2.2	91,588	26	78.8	9,571	71	159.8	1,693
-18	-0.4	86,463	27	80.6	9,164	72	161.6	1,637
-17	1.4	81,662	28	82.4	8,776	73	163.4	1,582
-16	3.2	77,162	29	84.2	8,407	74	165.2	1,530
-15	5	72,940	30	86	8,056	75	167	1,480
-14	6.8	68,957	31	87.8	7,720	76	168.8	1,431
-13	8.6	65,219	32	89.6	7,401	77	170.6	1,385
-12	10.4	61,711	33	91.4	7,096	78	172.4	1,340
-11	12.2	58,415	34	93.2	6,806	79	174.2	1,297
-10	14	55,319	35	95	6,530	80	176	1,255
-9	15.8	52,392	36	96.8	6,266	81	177.8	1,215
-8	17.6	49,640	37	98.6	6,014	82	179.6	1,177
-7	19.4	47,052	38	100.4	5,774	83	181.4	1,140
-6	21.2	44,617	39	102.2	5,546	84	183.2	1,104
-5	23	42,324	40	104	5,327	85	185	1,070
-4	24.8	40,153	41	105.8	5,117	86	186.8	1,037
-3	26.6	38,109	42	107.6	4,918	87	188.6	1,005
-2	28.4	36,182	43	109.4	4,727	88	190.4	974
-1	30.2	34,367	44	111.2	4,544	89	192.2	944
0	32	32,654	45	113	4,370	90	194	915
1	33.8	31,030	46	114.8	4,203	91	195.8	889
2	35.6	29,498	47	116.6	4,042	92	197.6	861
3	37.4	28,052	48	118.4	3,889	93	199.4	836
4	39.2	26,686	49	120.2	3,743	94	201.2	811
5	41	25,396	50	122	3,603	95	203	787
6	42.8	24,171	51	123.8	3,469	96	204.8	764
7	44.6	23,013	52	125.6	3,340	97	206.6	742
8	46.4	21,913	53	127.4	3,217	98	208.4	721
9	48.2	20,883	54	129.2	3,099	99	210.2	700
10	50	19,903	55	131	2,986	100	212	680
11	51.8	18,972	56	132.8	2,787	101	213.8	661
12	53.6	18,090	57	134.6	2,774	102	215.6	643
13	55.4	17,255	58	136.4	2,675	103	217.4	626
14	57.2	16,464	59	138.2	2,579	104	219.2	609