

To the Installer:

Please attach these instructions next to the water heater.

To the Consumer:

Please read these and all component instructions and keep for future reference.

BOCK[®]
WATER HEATERS

EZFIT

Atmospheric Gas Instruction Manual
EZ 75-76, EZ 100-76



Warranty, Registration Card and Parts List are included.
Homeowner: Please remember to return the Registration Card!

▲ WARNING

Improper installation, adjustment, alteration, service or maintenance can cause serious injury or property damage. Refer to this manual. For assistance or additional information, consult a qualified installer or service agency.

▲ WARNING

If the information in these instructions is not followed exactly, a fire or explosion may result causing property damage, personal injury or death.

▲ WARNING

Do not install on combustible flooring. Install in accordance with all local codes. In the absence of local codes, refer to ANSI 223.1/NFPA 54 and/or CSA B149.1.

▲ CAUTION

The recommended temperature for normal residential use is 120°F. The dial on the aquastat does not always reflect the out-coming water temperature and it could occasionally exceed 120°F. Variation in out-coming temperature could be based on factors including but not limited to usage patterns and type of installation. Test water at the tap nearest to the water heater. See page 9 for measuring the out-coming water temperature.

▲ WARNING

Hotter water increases the risk of scald injury. Before adjusting the water temperature setting, read this instruction manual. Temperatures at which injury occurs vary with the person's age and the length of exposure. The slower reaction time of children, elderly or physically or mentally challenged persons increases the scalding hazard to them. It is recommended that lower water temperatures be used where these exposure hazards exist. Households with small children or invalids may require a temperature setting less than 120°F to prevent accidental contact with hot water. **To produce less than 120°F, use point-of-use temperature limiting devices.**

If higher water temperature is needed in part of the water system, automatic temperature limiting devices must be used on all lines to water taps.

▲ WARNING

Flammable vapors may be drawn to this water heater from other areas of the structure by air currents. Do not store or use any flammable liquids in the vicinity of this heater.

▲ WARNING

Water heater blankets may restrict air flow to the water heater and cause fire, asphyxiation, personal injury or death.

THIS MANUAL HAS BEEN PREPARED TO ACQUAINT YOU WITH THE INSTALLATION, OPERATION, AND MAINTENANCE OF YOUR WATER HEATER AND TO PROVIDE IMPORTANT SAFETY INFORMATION.

Read all instructions thoroughly before attempting installation or operation of your water heater. Keep these instructions for future reference.

Local plumbing and electrical codes must be followed in the installation of this water heater. In the absence of a local code use the UNIFORM PLUMBING CODE and the NFPA Code. Local codes may supersede instructions in this installation manual.

These instructions are a guide for the correct installation of the water heater. The manufacturer will not be liable for damages caused by failure to comply with the installation and operating instructions outlined on the following pages.

Installation, testing, and replacement of gas piping, appliances, or accessories, and repair and servicing of equipment, shall be performed only by a qualified agency.

FAILURE TO FOLLOW THESE INSTRUCTIONS OR ALL APPLICABLE BUILDING CODES AND REGULATIONS VOIDS THE WARRANTY ON THIS WATER HEATER.

IMPORTANT SAFETY INSTRUCTIONS

⚠ WARNING

If the information in these instructions is not followed exactly, a fire or explosion may result causing property damage, personal injury or death.

FOR YOUR SAFETY!

- Do not store or use gasoline or other flammable vapors and liquids in the vicinity of this or any other appliance.
- WHAT TO DO IF YOU SMELL GAS
 - Do not try to light any appliance.
 - Do not touch any electrical switch; do not use any phone in your building.
 - Immediately call your gas supplier from a neighbor's phone. Follow the gas supplier's instructions.
 - If you cannot reach your gas supplier, call the fire department.
- Installation and service must be performed by a qualified installer, service agency or the gas supplier.

⚠ DANGER

Water heaters utilizing Liquefied Petroleum gas (LP) are different from natural gas models. A natural gas heater will not function safely on LP gas and vice versa. To avoid possible equipment damage, personal injury or fire: **DO NOT** connect this water heater to a fuel type not in accordance with the rating label. These units are only certified for a single fuel type.

⚠ DANGER

Failure to install the draft hood and properly vent the water heater to the outdoors as outlined in this manual can result in unsafe operation of the water heater. To avoid the risk of fire, explosion, or asphyxiation from carbon monoxide, never operate this water heater unless it is properly vented and has adequate air supply for combustion. Be sure to inspect the vent system for proper installation at initial start-up; and at least annually thereafter. See the Maintenance section for more information.

SAVE THESE INSTRUCTIONS

TABLE OF CONTENTS

Section I: Specifications 4

Section II: General Information. 5

Section III: Pre-Installation 7

Section IV: Installation 10

Section V: Operation 13

Section VI: Maintenance 15

Section VII: Troubleshooting 16

Section VIII: Parts List. 17

Section IX: Warranty 19

SECTION I: SPECIFICATIONS

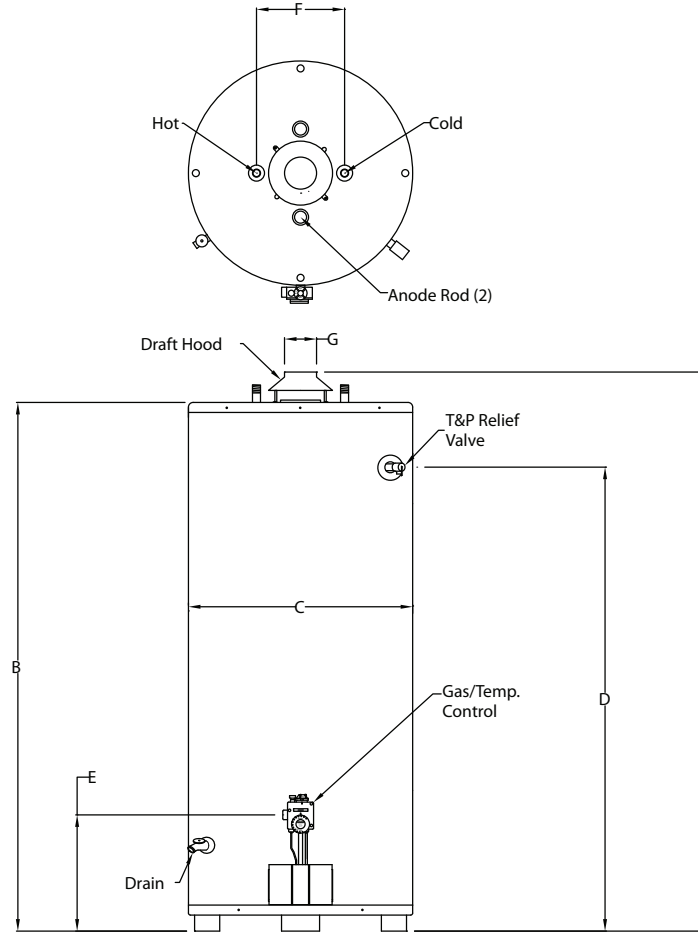

Figure 1: All Models

Table 1: Dimensions

Model	Storage (GAL)	Rated Input (BTU/HR)	Recovery @ 100°F Rise (GPH)	1st Hr. Delivery @ 100°F Rise (GAL)	DIMENSIONS (inches)							Inlet Conn. Dia.	Outlet Conn. Dia.	Gas Conn. Dia.	Shipping Weight (LBS)
					A	B	C	D	E	F	G				
EZ 75-76N	75	76,000	73	133	69.19	65.38	26.00	58.25	14.50	11.00	4.00	1.00	1.00	0.50	391
EZ 100-76N	100	76,000	73	153	69.81	66.00	28.00	57.94	14.50	11.00	4.00	1.00	1.00	0.50	485

For LP models change suffix "N" to "LP"

Working Pressure: 150 PSI (1034 kPa)
Test Pressure: 300 PSI (2068kPa)

For natural gas: Manifold pressure = 4" W.C. (1.00 kPa); Inlet pressure range 5-14" W.C. (1.25 - 3.49 kPa)
For propane gas: Manifold pressure = 10" W.C. (2.49 kPa); Inlet pressure range 11-14" W.C. (2.74 - 3.49 kPa)
T&P valve installed

All Bock products meet or exceed current ASHRAE standards.
These products are design certified by UL (Underwriters Laboratories) and meet ANSI Z21.10.3 requirements for operation up to 180°F (82°C).
Approved for use as an automatic circulating tank water heater or automatic storage water heater.

WARNING: Do not install on combustible flooring. Installation shall be in accordance with all national and/or local codes.
In the absence of local codes, refer to NFPA 54 and/or CSA B149.1.

CAUTION: The recommended maximum hot water temperature setting for normal residential use is 120°F (49°C). Bock recommends a tempering valve or anti-scald valve be installed and used according to the manufacturer's directions to prevent scalding.

SECTION II: GENERAL INFORMATION

WHEN YOU RECEIVE YOUR NEW WATER HEATER

Check the new equipment to see if all components are in good condition. If damage is observed or parts appear to be missing, contact your wholesaler.

WATER TREATMENT/FILTRATION

In areas where poor water conditions are suspected (i.e. lime, iron, and other minerals), it is essential that the water be tested and appropriate action taken to prevent damage to the water heater and ensure the quality of the water.

TEMPERATURE CONTROL

The water heater is equipped with a gas thermostat to monitor tank temperature and control operation of the main burner. For domestic hot water, the proper temperature setting is 120°F. For commercial applications, the maximum approved temperature setting is 180°F.

A built in, non-cycling Energy Cut-Off (ECO) is standard on all gas thermostats. In the event that the water temperature becomes excessive (200°F), the ECO will shut off all gas to the water heater. If an ECO has detected an over-temperature condition and has opened, the control will not function and a replacement will be required.

The thermostat is factory set at 120°F. See Figure 6 for thermostat letter and temperature relationships. If hotter water is required a tempering device or anti-scald device must be installed at the domestic hot water outlet of the heater or at the point of use. Table 3 details the approximate relationship of water temperature and time with regard to scald injury. It is important for the user to understand the necessity of tempering or anti-scald devices when using hotter water in domestic water heating systems.

⚠ CAUTION: Hot water in excess of 120°F can cause scalding!

Bock recommends a tempering valve or anti-scald valve be installed and used according to the manufacturer's directions to prevent scalding. Many state and local codes now require installation of these devices. The tempering valve or anti-scald valve will ensure potable water temperatures at the desired set point with a higher degree of accuracy.

Table 2: Scald Temperature/Time Relationships

APPROXIMATE TEMPERATURE/TIME RELATIONSHIPS TO SCALDING	
120°F	More than 5 minutes
125°F	1 ½ to 2 minutes
130°F	About 30 seconds
135°F	About 10 seconds
140°F	Less than 5 seconds
145°F	Less than 3 seconds
150°F	About 1 ½ seconds
155°F	About 1 second



SECTION II: GENERAL INFORMATION (cont.)

ANODE RODS

The anode rod is used as a sacrificial element within the volume of the storage tank. The purpose of the magnesium anode rod is to protect the inside of the tank against corrosion. Anode rods should be inspected twice in the first year and at least yearly once a time interval for inspection has been developed. Water conditions can influence the consumption rate of the anode rods. Please see the Maintenance section of this manual for instructions on how to change the anode rods.

⚠ CAUTION

Hydrogen gas is produced in a hot water system served by the heater that has not been used for a long period of time (2 weeks or more). Hydrogen gas is extremely flammable. To reduce the risk of injury under these conditions, it is recommended that the hot water faucet be opened for several minutes at the kitchen sink before using any electrical appliance connected to the hot water system. When hydrogen is present, there will probably be an unusual sound such as air escaping through the pipe as the water begins to flow. There should be no smoking or open flame near the faucet at the time it is open.

TEMPERATURE AND PRESSURE RELIEF VALVE (T&P)

⚠ CAUTION

To reduce the risk of excessive pressures and temperatures in this water heater, install temperature and pressure protective equipment required by local codes and no less than a combination temperature and pressure relief valve certified by a nationally recognized testing laboratory that maintains periodic inspection of production of listed equipment or materials, as meeting the requirements for Relief Valves and Automatic Gas Shutoff Devices for Hot Water Supply Systems, ANSI Z21.22. This valve must be marked with a maximum set pressure not to exceed the marked maximum working pressure of the water heater. Install the valve in an opening provided and marked for this purpose in the water heater, and orient it or provide tubing so that any discharge from the valve exits only within 6 inches above, or at any distance below, the structural floor, and does not contact any live electrical part. The discharge opening must not be blocked or reduced in size under any circumstances.

⚠ CAUTION

Scalding injury and/or water damage can occur from either the manual lifting of the lever or the normal operation of the T&P valve. If it is not piped to a proper drain. If the valve fails to flow water or reseal, call your plumber.

The T&P valve is factory installed. A discharge drain tube must be installed (responsibility of the installer) and shall terminate plain, not threaded, 6 inches above the floor drain. The drain tube material must be approved for temperatures of 120°F or greater and a pressure of 150 PSI or greater.

SECTION II: GENERAL INFORMATION (cont.)

BACKFLOW PREVENTER (CLOSED SYSTEM)

Some local municipal codes and ordinances require the use of these devices on potable (domestic) water lines. Where backflow preventers are required, it will be necessary to install a **thermal expansion tank** (designed for use with potable water) in order to prevent pressure build up in the water heater and associated piping, which could cause the T&P valve to discharge. Follow the expansion tank manufacturer's recommendations when selecting a tank for your hot water system.

Note: Working pressure of the water heater is 150 PSI. Do not exceed 150 PSI.

SECTION III: PRE-INSTALLATION

LOCATION

▲ CAUTION

This water heater must be located in an area where leakage of the tank, water line connections, or the temperature and pressure relief valve will not result in damage to the area adjacent to the water heater or to lower floors of the structure. When such location cannot be avoided, a suitable drain pan must be installed under the water heater. The drain pan depth must be suitable for draining and collecting water. The drain pan can be purchased from your plumbing professional. The drain pan must be piped to an adequate drain and all drain piping must be at least 0.75" in diameter and pitched for proper drainage.

▲ CAUTION

DO NOT store or use gasoline or other flammable, combustible, or corrosive vapors and/or liquids in the vicinity of the water heater or any other appliance.

IF YOU SMELL GAS:

- **DO NOT** try to light any appliance.
- **DO NOT** touch any electric switch; do not use any telephone in your building.
- Immediately call your gas supplier from a telephone in another building. Follow your gas supplier's instructions.
- If you cannot reach your gas supplier, call the fire department.

DO NOT OPERATE THE APPLIANCE UNTIL THE LEAKAGE IS CORRECTED!

▲ CAUTION

Do not drop water heater or lay heater down on its side. Move the water heater into position by sliding or using an appropriately sized hand truck.

SECTION III: PRE-INSTALLATION (cont.)

NOTE: Locate the heater so it is not subject to physical damage from moving vehicles or flooding. Do not locate the water heater in a room where swimming pool chemicals or large quantities of water softener salt are kept. Installing a water heater in this environment will result in premature failure of tank and burner components due to corrosion caused by these elements diffusing into the air.

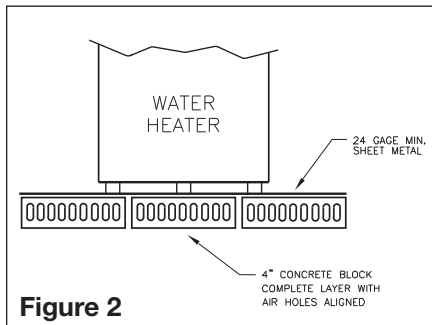

Figure 2

DO NOT INSTALL THE WATER HEATER ON COMBUSTIBLE FLOORING. Place on noncombustible flooring and maintain clearances prescribed by this manufacturer and per code NFPA 54. If the water heater must be located on combustible flooring it must be raised off the floor with a layer of 4" concrete block laid so the air holes are aligned as shown in Figure 2. Consult with local code officials before using this method. Please consult local codes, NFPA 54 and/or contact Bock Water Heaters with questions concerning

proper flooring materials. Leave adequate room for periodic maintenance of heater and burner. The water heater should be placed as near to the chimney as practical in order to keep vent connector length to a minimum. Consult National Fuel Gas Code for proper vent configuration.

Minimum clearance to combustible construction is: SIDES 6"; BACK 6"; FRONT 24"; DRAFT HOOD; 18". The installation of this water heater must conform with local codes and ordinances. In the absence of local codes, the installation must comply with the National Fire Protection Association (NFPA 54) Code.

COMBUSTION AND VENTILATION AIR

The water heater must be installed in a location with an adequate air supply for combustion, ventilation and draft control. Unsafe levels of carbon monoxide (CO), condensation and sooting may result if the room does not have an adequate air supply. See "National Fuel Gas Code (NFPA 54)" or the discussions of "Unconfined Space" and "Confined Space" below. Poor ventilation will also result in hot spots around the heater. Temperatures over 90°F near the water heater generally indicate a lack of ventilation.

UNCONFINED SPACE

Unconfined space is defined by NFPA 54 as a space with a volume greater than 50 cubic feet (during typical use) per 1000 BTUH of the total combined input of all fuel burning appliances in the space. Rooms leading directly to the installation space through doors that cannot be closed can be considered part of the space. **Exception: Buildings with full vapor barriers, tight doors and windows or air infiltration rates of less than 0.35 air changes per hour will be considered a confined space and require additional air supplies.**

CONFINED SPACE

Confined space is defined by NFPA 54 as a space with a volume less than 50 cubic feet (during typical use) per 1000 BTUH of the total combined input of all fuel burning appliances in the space. Buildings or rooms of unusually tight construction are also considered a confined space. See "**Unconfined Space: Exception**".

When installing fuel burning appliances in a confined space, air must be supplied to that space from either inside or outside of the building as conditions allow.

A. Inside Air Supply: A confined space shall be provided with two permanent openings; one within 12 inches of the top and one within 12 inches of the bottom of the enclosure. These openings shall lead directly to room(s) of sufficient volume so that the combined volume of all the space meets the criteria for unconfined space. Each opening shall have a minimum free area of 1 square inch per 1000 Btu/hr of the combined total input of all fuel burning appliances in the space. Each opening shall have an area of not less than 100 square inches or a minimum dimension of not less than 3 inches.

SECTION III: PRE-INSTALLATION (cont.)

CONFINED SPACE (CONT.)

B. Outside Air Supply: Confined spaces shall be provided with two permanent openings; one within 12 inches of the top and one within 12 inches of the bottom of the enclosure. These openings shall communicate directly, or by ducts, with the outdoors or spaces that communicate with the outdoors.

1.) Leading directly to the outside or through vertical ducts: Each opening shall have a minimum free area of one square inch per 4000 Btu/hr of total input rating of all equipment in the enclosure.

2.) Leading to outside through horizontal ducts: Each opening shall have a minimum free area of one square inch per 2000 Btu/hr of total input rating of all equipment in the enclosure.

Note: All ducts shall have the same cross sectional area as the free area of each opening to which they connect. The minimum dimensions of all ducts shall not be less than three inches. Powered combustion air supplies are also commercially available and may be used.

LOUVERS & GRILLES

In calculating the free area of an opening, consideration must be given to the blocking effects of louvers or grilles protecting the opening. Any screens used must be no finer than $\frac{1}{4}$ inch mesh. If the free area of a louver or grille is known, this should be used in calculating the size of opening required. If free area is unknown, it may be assumed that wood louvers will have 20 to 25% free area and metal louvers and grilles will have 60 to 75% free area. Louvers and grilles should be fixed in the open position or interlocked with the equipment so that they open automatically during equipment operation.

VENTING

The water heater shall be located as close to the chimney as practical. Long lateral runs will result in intermittent combustion problems and unsafe operating conditions. Total vent height should be a minimum of 6 feet. Shorter vent heights could result in unstable draft and nuisance lock outs.

The venting system should be sized according to National Fuel Gas Code: NFPA 54/ANSI Z223.1 (most recent edition) using the "Natural" column. If you do not have a copy of this code one can be obtained at www.NFPA.org for a nominal fee. Copies of the NFPA venting tables are also reprinted in the Bock Engineering Manual available from your Bock Representative or by download from www.bockwaterheaters.com. **Note:** Do not reduce vent size more than one size smaller than the vent connector supplied with the heater. If vent size must be reduced one size, use full size vent connectors on the vent hood and reduce vent size as far from the water heater as practical. B vent, L vent or multi-fuel venting may be used. Vent tables supplied by the vent manufacturer may also be used in sizing the vent system.

Venting system must be capable of producing -0.02 " WC (inches of water column) draft minimum. If draft of -0.02 " WC cannot be produced with an existing vent system, a draft inducer may be required. Installations common vented with large vent hood equipped appliances such as heating boilers may require vent dampers on the heating boiler connectors for proper vent operation during no-heating season.

Check the building for items that can cause severe negative pressure problems such as large exhaust fans. If these devices are installed in the same building check for their effect on draft and combustion. All fuel burning appliances must be isolated from the effects of these devices to operate properly. Failure to address this issue will result in unsafe operation and shorten appliance life spans.

Your Bock water heater may also be operated with a power venter. The power venter must be properly sized and adjusted to provide proper draft. Power venter wiring must turn on the power venter on a call for heat and must prove venter operation before allowing the burner to start. Refer to the power venter instructions for proper wiring and adjustment procedures.

SECTION IV: INSTALLATION

WATER CONNECTIONS

CAUTION

This water heater incorporates fittings that contain a nonmetallic lining. DO NOT apply heat to these fittings when making sweat connections to the heater. Sweat tubing to an adapter before securing adapter to any fittings on water heaters.

ALL PIPING SHOULD CONFORM TO LOCAL CODES AND ORDINANCES. It is highly recommended that unions and shut-off valves are installed at the potable water connections to allow for isolation and/or movement during service. All piping should be adequately insulated with an approved material to minimize heat loss.

POTABLE WATER CONNECTIONS

THE WATER HEATER MUST BE FILLED WITH WATER BEFORE LIGHTING THE BURNER.

1) Close the main water supply valve before continuing with the installation. After the main water supply is shut-off, relieve the water line pressure by opening a faucet. Once the pressure has been relieved, close the faucet. The “Cold” and “Hot” potable water connections are labeled on the water heater. Install a union and shut-off valve at both potable water connections. All piping should be 3/4” diameter new copper or larger. A tempering valve or anti-scald valve should be installed at the potable water outlet and used according to the manufacturer’s specifications to prevent scalding.

2) If a backflow preventer is required in the cold water supply, a properly sized expansion tank must be installed to control thermal expansion. Do not operate the water heater in a closed system without installing a thermal expansion tank. Follow the expansion tank manufacturer’s recommendations when selecting a tank for your system.

3) Following installation of the water lines, open the main water supply valve and fill the water heater. Open several hot water faucets to relieve air from the system. After water is flowing through the faucets and the system is void of air, close the faucets and check for water leaks in the system.

Note: Do not try to heat hard water as this will drastically reduce heater life. Install a water softener or other scale reducing water treatment system if the water heater is being installed in a hard water area (water hardness higher than seven grains).

SECTION IV: INSTALLATION (cont.)

GAS CONNECTIONS

CAUTION

Do not use this water heater with any gas other than the type listed on the rating label. Check the rating label on the front of the water heater and make sure the gas to be used matches the gas stated on the rating label. Consult your local gas company or Bock Water Heaters with any questions.

A manual valve, union, and a sediment trap should all be provided in front of the gas thermostat. All gas piping must conform to local codes and/or the National Fuel Gas Code, ANSI 223.1/NFPA 54 (latest edition).

Supply piping should be sized according to the charts found in the National Fuel Gas Code for natural gas applications.

Note: When sizing the gas piping to the heater, make sure that the pressure at the valve is sufficient when all other appliances are operating. Undersized gas piping will reduce water heater performance and life as well as result in nuisance lockouts. Also verify that the gas service and meter are sized properly for the load.

Gas piping should be carried oversize, i.e.: $\frac{3}{4}$ inch or 1 inch or larger for $\frac{1}{2}$ inch valve to within 2 feet of the valve itself. This sustains pressure at the valve during start-up to prevent flashbacks caused by momentary pressure loss. For natural gas, 5" W.C. pressure must be maintained upstream of the gas valve during operation. For LP gas, a minimum of 11" W.C. must be maintained upstream of the gas valve. A $\frac{1}{8}$ inch NPT pipe connection should be installed upstream of the manual shut-off valve to check incoming gas pressure.

During pressure testing of the gas supply piping, close the manual gas shut-off valve to the water heater. Test pressure shall not exceed $\frac{1}{2}$ PSIG (14" W.C.). The gas valve is only rated for $\frac{1}{2}$ PSIG. To test at pressure greater than $\frac{1}{2}$ PSIG, close the manual shut-off valve and disconnect the gas operating valve.

Turn on gas and inspect piping for leaks by "painting" each joint with soap and checking for bubbles. Do not use open flame. The pipe thread compound that is used on gas piping must be of the type resistant to propane gas. Do not use teflon tape on gas piping. **Note:** For high altitude applications (above 2000 feet) contact Bock Water Heaters.

DRAFT HOOD AND VENTING

This water heater must be installed with the factory supplied draft hood. See Figure 3 for placement. Vent connectors must be attached to the draft hood to connect the water heater to the gas vent or chimney. The vent connector must be the same diameter as the outlet of the draft hood. Never use a smaller diameter vent connector. Horizontal vent connectors must be pitched upward to the chimney at least $\frac{1}{4}$ " per foot of length. Vent connector joints should be securely fastened with sheet metal screws. For further specifications, see the National Fuel Gas Code (NFPA 54).

DANGER

Substitution, elimination or relocation of the draft hood will result in unsafe operation and void the warranty of your water heater. Improper venting or misuse of the draft hood can result in unsafe operation causing bodily injury, explosion, fire or death. To avoid the risk of fire, explosion, or asphyxiation from carbon monoxide, NEVER operate this water heater unless it is properly vented and has an adequate air supply.

SECTION IV: INSTALLATION (cont.)

DRAFT HOOD INSTALLATION

1. Locate the two predrilled holes in the top pan.
2. Align and insert the draft hood legs (without screw holes) into the holes in the top pan.
3. Using a drill and the two sheet metal screws (supplied), fasten the other two legs (with screw holes) to the top pan. The draft hood should now be securely joined to the water heater.

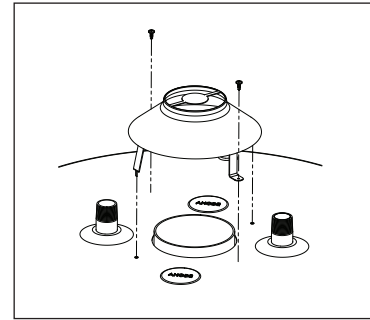

Figure 3: Install Draft Hood

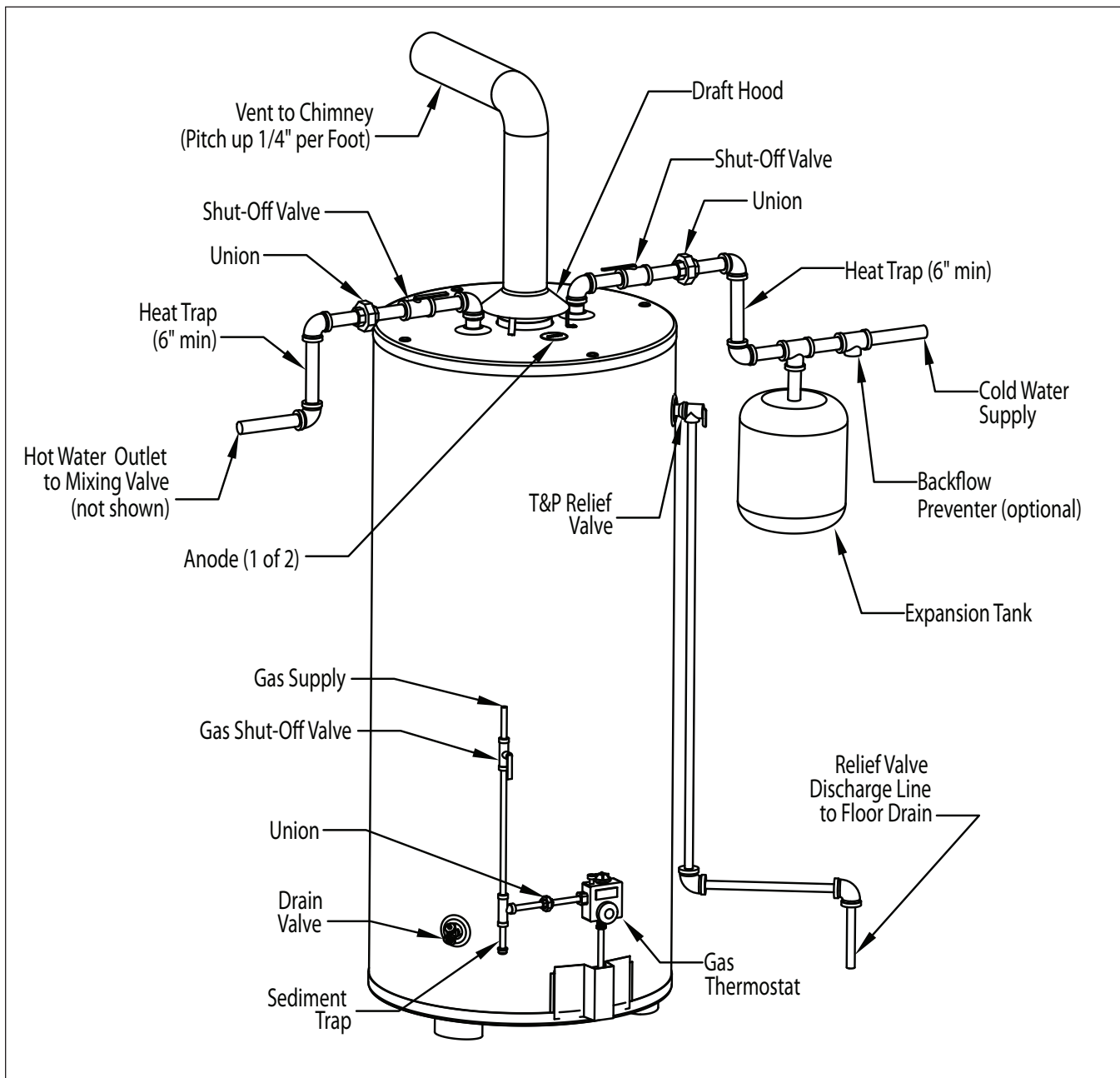

Figure 4: Recommended Water, Gas, Vent Connections

SECTION V: OPERATION

FOR YOUR SAFETY READ BEFORE LIGHTING

WARNING: If you do not follow these instructions exactly, a fire or explosion may result causing property damage, personal injury or loss of life.

- A. This appliance has a pilot which must be lighted by hand. When lighting the pilot, follow these instructions exactly.
 - B. **BEFORE LIGHTING** smell all around the appliance area for gas. Be sure to smell next to the floor because some gas is heavier than air and will settle on the floor.
 - C. Use only your hand to push in or turn the gas control knob. Never use tools. If the knob will not push in or turn by hand, don't try to repair it, call a qualified service technician. Force or attempted repair may result in a fire or explosion.
 - D. Do not use this appliance if any part has been under water. Immediately call a qualified service technician to inspect the appliance and to replace any part of the control system and any gas control which has been under water.
- WHAT TO DO IF YOU SMELL GAS**
- Do not try to light any appliance.
 - Do not touch any electric switch; do not use any phone in your building.
 - Immediately call your gas supplier from a neighbor's phone. Follow the gas supplier's instructions.
 - If you cannot reach your gas supplier, call the fire department.

LIGHTING INSTRUCTIONS

1. **STOP!** Read the safety information above on this label.
2. Set the thermostat to lowest setting.
3. Turn gas control knob clockwise to "OFF."
4. Wait five (5) minutes to clear out any gas. If you then smell gas, **STOP!** Follow "B" in the safety information above on this label. If you don't smell gas, go to the next step.
5. Remove both access panels and insulation located below the gas control.
6. Find pilot - follow metal tube from gas control. The pilot is mounted on a bracket at an upward angle.
7. Turn gas control knob counterclockwise to "PILOT."
8. Push in gas control knob or pilot gas button all the way and hold in. Immediately light the pilot with a match or multi-purpose lighter. Continue to hold the control knob in for about one (1) minute after the pilot is lit. Release knob or button and it will pop back up. Pilot should remain lit. If it goes out, repeat steps 3 through 8.
 - If the knob does not pop up when released, stop and immediately call your service technician or gas supplier.
 - If the pilot will not stay lit after several tries, turn the gas control knob to "OFF" and call your service technician or gas supplier.
9. Return both access panels and the insulation to their respective locations.
10. Turn gas control knob counterclockwise to "ON."
11. Set thermostat to desired setting.

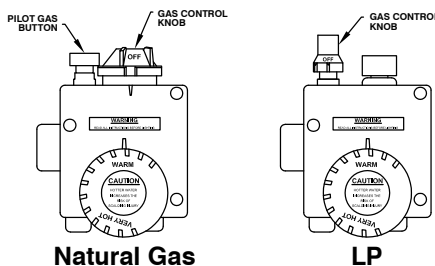

TO TURN OFF GAS TO APPLIANCE

1. Set the thermostat to lowest setting.
2. Turn gas control knob clockwise to "OFF."

REPLACING THE GAS CONTROL

1. The thermostat is designed with a single-use gas shutoff device. In the event that the gas shutoff circuit is open, the control must be replaced. **STOP! DO NOT ATTEMPT TO OPERATE THE APPLIANCE. CALL A QUALIFIED SERVICE TECHNICIAN TO REPLACE THE GAS CONTROL.**
2. Turn the gas control knob clockwise to "OFF."
3. Turn off all gas to the appliance and remove the gas line from the gas control.
4. Drain all water from the tank of the appliance. See instruction manual for further information.
5. Loosen and remove the thermocouple, main burner tube, and pilot burner tube connection from the bottom of the gas control.
6. Remove the gas control from the tank (turn counterclockwise to loosen).
7. Install the new gas control into the tank (turn clockwise to tighten) and reconnect the thermocouple, main burner tube, pilot burner tube and gas line to the gas control.
8. Refill the appliance with water. See instruction manual for further information.
9. With the gas control set to "OFF" turn on gas to the appliance. Check for leaks in the gas line and at the main burner tube and pilot burner tube connection to the gas control. If a leak is detected, **STOP!** Follow the safety instructions above on this label.
10. To put the appliance back into operation, follow the safety information and lighting instructions above on this label.

23079

Figure 5: Instructions To Put The Water Heater In Operation

SECTION V: OPERATION (cont.)

INSPECT THE INSTALLATION AND ADJUST THE CONTROLS

During the initial warm-up of the stored water, check for proper combustion by sampling combustion gas at a point just below the exit of the flue. O₂ readings should be in the range of 4.5-5.0% with CO levels at 0 ppm. Both combustion chamber access panels and insulation (placed between panels) shall be installed when performing the combustion test. O₂ readings that greatly deviate from the specified range may lead to unsafe operating conditions. Factors that can lead to O₂ levels outside of the specified range include inadequate or excess draft caused by ambient conditions or venting, obstructions underneath the water heater preventing sufficient flow of air to burner, and improper inlet or manifold gas pressures. For natural gas, the manifold pressure is preset at 4.0" w.c. and the acceptable inlet pressure is in the range of 5-14" w.c. For propane gas, the manifold pressure is preset at 10.0" w.c. and the acceptable inlet pressure is in the range of 11-14" w.c. See the "Pre-Installation" section of this manual for information on clearances, air supply, and venting.

The thermostat has been adjusted to 120°F at the factory. Wait until thermostat has shut off gas to the main burner. Wait 30 seconds following shut-off of gas, then set thermostat to the highest temperature. The main burner should relight. Set thermostat to the lowest temperature; the main burner should go out. The thermostat should be adjusted to the minimum setting that will meet the hot water needs of the homeowner or commercial application.

⚠ CAUTION

There is a scald potential if the thermostat is set too high. The recommended temperature setting for normal residential use is 120°F. If higher temperature settings are needed for combined appliance applications or commercial use, an automatic tempering valve must be installed on all domestic hot water lines.

MEASURING THE OUTCOMING WATER TEMPERATURE

The thermostat is factory set at 120°F for domestic use. It is the responsibility of the building owner to verify that the installer follows the recommended quantitative testing for measuring the outlet water temperature. To make sure that the system works properly after installation and in the future, it is recommended that the heater's performance be measured and monitored. Run water out of the tap nearest the heater until it comes out warm. Using a calibrated thermometer, take a measurement. If the water is not at a suitable temperature for the installation, have a qualified service person adjust the temperature control. Contact Bock for further information if needed.

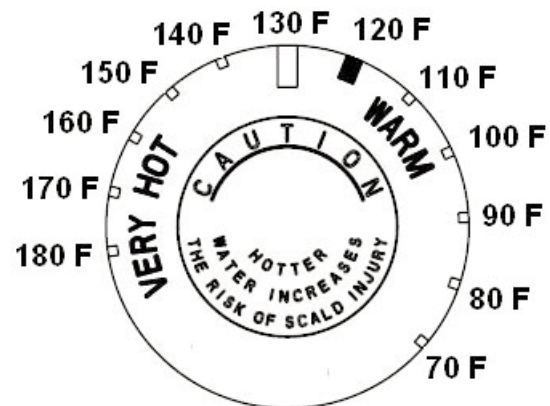

Figure 6: Approximate Temperature and Dial Setting Relationship

This log (or a similar one) should be filled out as follows:

Date	Time	Person running test	Set temp °F	Outlet temp °F

SECTION VI: MAINTENANCE

NOTICE TO THE OWNER: If you are having a mechanical problem with your water heater, contact your service company or installer.

WATER PIPING

On an annual basis, all piping should be checked for leakage at joints, shut-off valves, and unions.

T&P RELIEF VALVE

On an annual basis, the temperature and pressure relief valve should be checked for proper operation. First, attach a drain line to the valve to direct the water discharge to an open drain. This is very important because the temperature of the discharge could be very hot. Second, lift the lever at the end of the valve several times. The valve should operate freely and return to its original position properly. If water does not flow out of the valve, remove and inspect for corrosion or obstructions. Replace with a new valve if necessary. Do not repair the faulty valve as this may cause improper operation.

ANODE RODS

Anode rods should be inspected twice in the first year and at least yearly once a time interval for inspection has been developed. It is recommended to check the rod(s) six months after the heater is installed. If the anode rod had reduced in size by two-thirds of its original diameter of 3/4" or shows signs of pitting, it is time for replacement. Take the following steps when changing the anode rod(s):

1. Shut off water supply.
2. Open any faucet to relieve tank pressure.
3. Remove caps on water heater top; push insulation aside.
4. Use a 1 1/16" six-sided socket wrench and a breaker bar. Snap hard to break the anode rod seal.
5. Remove rod(s) and replace with new rod(s).
6. Turn water supply back on and leave faucet open until air is out of line.
7. Turn faucet off and check that new rod(s) doesn't leak.
8. Snap caps back into place.

FLUSH THE TANK

Elements in the water such as lime and iron may accumulate in the heater. Accumulation of these elements can keep your water heater from operating at peak efficiency and may lead to premature tank failure. It is recommended that the tank is drained and flushed thoroughly once a year to prevent buildup.

SECTION VI: MAINTENANCE (cont.)

INSPECT THE VENTING SYSTEM

The vent system should be checked at least once a year for damage and blockage. A draft and combustion test is also recommended.

If necessary, the water heater flue may be cleaned with a brush or flexible wire. Before proceeding:

- 1) Turn the gas valve OFF.
- 2) Wait at least 5 minutes for the combustion chamber and flue to cool.
- 3) Use a brush or flexible wire to clean the flue. This can be done through the top of the flue. It is not necessary to remove the burner.
- 4) Slide the brush down the flue at the base of each row of fins. This should knock any rust flakes into the combustion chamber for removal.

⚠ WARNING

If the flue is blocked with soot this indicates serious combustion problems related to the building and/or installation. These must be addressed before placing the water heater back in operation.

- 5) Vacuum any sediment collected in the combustion chamber before restarting the heater. Access to the combustion area can be obtained through the removal of the two access panels and insulation. Be sure to replace all parts to their original positions prior to operating the water heater.

SECTION VII: TROUBLESHOOTING

⚠ CAUTION

For your safety, the repair and servicing of this equipment shall only be performed by a qualified agency.

Table 3: Troubleshooting

Problem	Possible causes	Recommended Action
Cannot light pilot	<ol style="list-style-type: none"> 1) Gas control knob not positioned correctly 2) Air in gas line 3) Clogged pilot orifice 4) Pinched pilot tube 5) Pilot tube leaking 	<ol style="list-style-type: none"> 1) Refer to lighting instructions 2) Purge gas line 3) Clean or replace 4) Repair or replace 5) Tighten connection at thermostat
Pilot will not stay lit when gas control knob or pilot gas button is released.	<ol style="list-style-type: none"> 1) Thermocouple connection is loose 2) Bad thermocouple 3) Safety magnet breakdown 4) Single use gas shut-off device opened in thermostat 	<ol style="list-style-type: none"> 1) Tighten connection at thermostat 2) Replace thermocouple 3) Replace thermostat * 4) Replace thermostat *
Poor combustion (sooting, CO)	<ol style="list-style-type: none"> 1) Accumulation of scale on burner 2) Combustion air openings or flue/venting restricted 3) Inadequate combustion/ventilation air to room 	<ol style="list-style-type: none"> 1) Turn OFF burner and clean 2) Inspect and clean. 3) See "Pre-Installation" section
Rumbling noise during burner operation	<ol style="list-style-type: none"> 1) Scale or sediment build-up in tank 	<ol style="list-style-type: none"> 1) Clean/flush tank
Insufficient hot water	<ol style="list-style-type: none"> 1) Heater undersized for load 2) Low gas pressure 	<ol style="list-style-type: none"> 1) Reduce hot water usage rate 2) Check gas supply and manifold pressure
Water too hot or not hot enough	<ol style="list-style-type: none"> 1) Thermostat set too high or low 2) Thermostat out of calibration 3) Excessive water temperature and pilot failure. 	<ol style="list-style-type: none"> 1) Adjust setting as required 2) Replace thermostat * 3) Replace thermostat *

* In the event that the gas thermostat needs to be replaced, contact a qualified agency to perform the replacement.

SECTION VIII: PARTS LIST

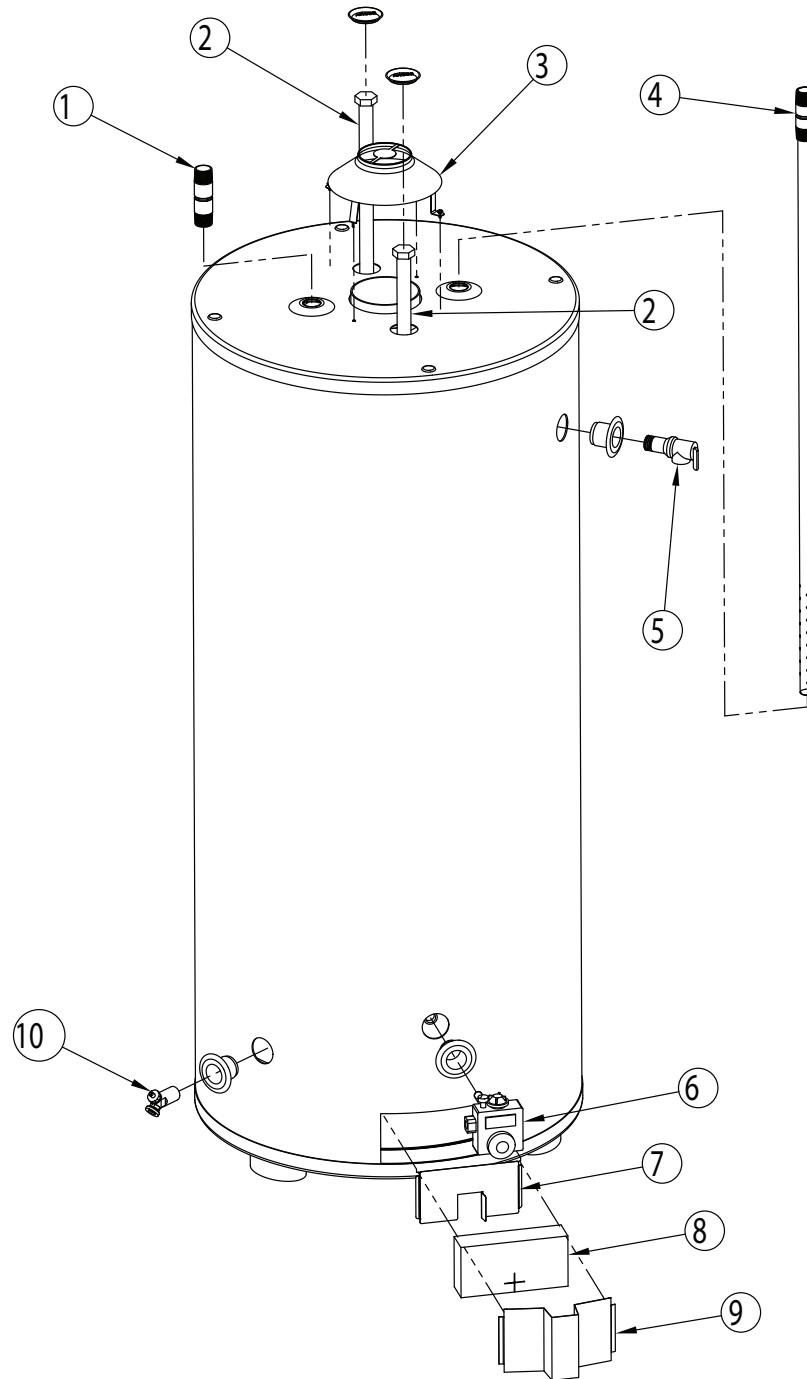

Figure 7: ezFIT Parts

Table 4: ezFIT Parts

Part Description	
1	Hot Outlet Nipple
2	Anode Rods
3	Draft Hood
4	Dip Tube
5	T&P Relief Valve
6	Gas Thermostat
7	Inner Access Door
8	Insulation
9	Outer Access Door
10	Drain Valve

SECTION VIII: PARTS LIST (cont.)

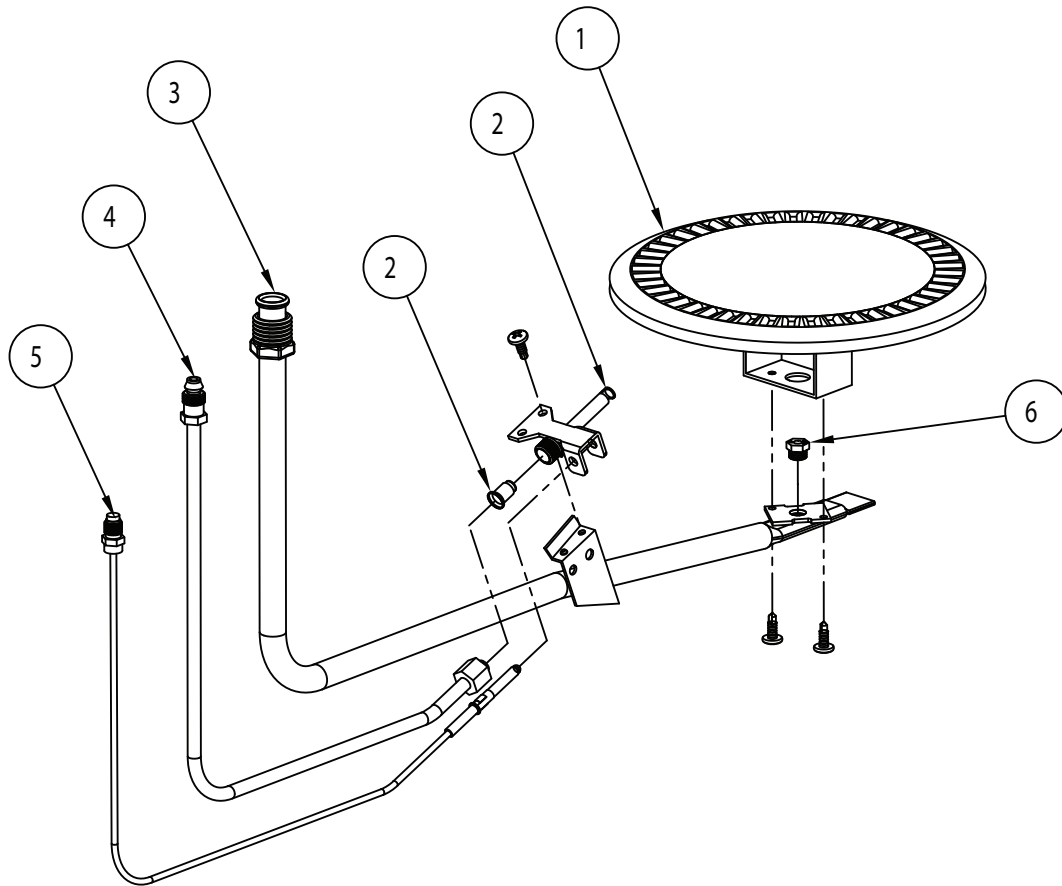

Figure 8: ezFIT Burner Parts

Table 5: ezFIT Burner Parts

Part Description	
1	Burner
2	Pilot Kit
3	Main Burner Tube
4	Pilot Tube
5	Thermocouple
6	Orifice (Natural or LP)

SECTION IX: WARRANTY

LIMITED WARRANTY FOR GAS-FIRED WATER HEATER

Bock Water Heaters, Inc.
110 S. Dickinson Street
Madison, WI 53703
Phone: 608-257-2225

WHAT DOES THIS LIMITED WARRANTY COVER?

This limited warranty applies only to the original consumer purchaser.

General Defects and Malfunctions: This warranty covers defections and malfunctions in your new water heater for a period of one year from the original installation date. We will repair or replace, at our option, any defective or malfunctioning component of the water heater. This limited warranty will terminate if you sell or otherwise transfer the water heater, or the water heater is installed at a location different from its original installation location.

Tank and Heat Exchanger: We also warrant that the tank and heat exchanger will not leak due to defective materials or workmanship for five years from the date of original installation or from date of manufacture in the event the Limited Warranty Registration Card was not completed and returned to manufacturer. If the tank and heat exchanger is leaking and we have verified that the leak is due to a defect in materials and workmanship, we will replace the tank with a tank that is the nearest Bock model available at the time of replacement. If a replacement tank is provided, it will remain warranted under this section as if it were the original tank. For example, if we send you a replacement tank under this limited warranty two years after the original installation date, then the replacement tank will remain warranted for the remaining three years after the original installation date.

HOW DO YOU GET SERVICE UNDER THE LIMITED WARRANTY?

In order for the warranty period to begin on the date of installation, you must return the warranty registration card attached below within 30 days of purchasing the water heater. You may also register your water heater online at www.bockwaterheaters.com. You must have a copy of the original sales receipt at the time you request service. Failure to return the warranty registration card and provide a copy of the sales receipt will result in the warranty period beginning from the date of manufacture.

To get service under this limited warranty you should contact either the dealer or installer. If dealer or installer is unknown you can contact us via e-mail at warranty@bockwaterheaters.com or call us Monday through Friday between the hours of 8 o'clock a.m. to 5 o'clock p.m. Central Time at the following number: 1-608-257-2225.

You can also write us at the following address:

Bock Water Heaters, Inc.
Warranty Support Group
110 S. Dickinson Street
Madison, WI 53703

We will respond not later than ten days after we have received your request for service.

SECTION IX: WARRANTY (cont.)

WHAT DOES THIS LIMITED WARRANTY NOT COVER?

This limited warranty does not cover water heaters that are or were:

- Incorrectly installed, especially where the installation violates state or local plumbing, housing or building codes.
- Operated at inappropriate settings, excessive pressures or temperatures.
- Exposed to adverse local conditions and specifically sediment or lime precipitation in the tank or corrosive elements in the atmosphere or unacceptable water quality.
- Installed outside the United States or Canada.
- Accidentally damaged.

Also, we will not cover the following charges, costs and losses:

- Any freight or delivery charges.
- Any removal or installation charges.
- Charges to return the water heater or part to the manufacturer.
- Water damage, loss or damage to property, inconvenience or loss of use.

WHAT WILL VOID THE LIMITED WARRANTY?

If you do any of the following, you will void this limited warranty:

- Fail to retain an original copy of your sales receipt.
- Fail to retain the actual rating plate from the water heater.
- Alter or remove the serial number.
- Transfer or sell the water heater.
- Remove the water heater from its original location and install it somewhere else.
- Fail to follow the care and maintenance instructions provided with the water heater.
- Remove the anode rods.
- Fail to inspect and replace the anode rods (you must retain and present your paid receipts as proof of anode rod replacement).

HOW DOES STATE LAW RELATE TO THIS LIMITED WARRANTY?

This is a limited warranty. WE MAKE NO OTHER EXPRESS WARRANTIES WITH RESPECT TO THIS WATER HEATER. We will not assume, nor authorize any person to assume for us any other liability in connection with the sale or operation of this water heater. ANY IMPLIED WARRANTIES, INCLUDING MERCHANTABILITY OR FITNESS FOR A PARTICULAR APPLICATION, IMPOSED ON THIS SALE UNDER THE LAWS OF THE STATE OF SALE ARE LIMITED TO ONE YEAR. This warranty gives you specific legal rights, and you may also have other rights which vary from state to state. Some states do not allow limitations on how long an implied warranty lasts, so the above limitation may not apply to you.

WE WILL NOT BE RESPONSIBLE FOR WATER DAMAGE, LOSS OF USE OF THE UNIT, INCONVENIENCE, LOSS OR DAMAGE TO PERSONAL PROPERTY, WHETHER DIRECT OR INDIRECT, AND WHETHER ARISING IN CONTACT OR TORT. Some states do not allow the exclusion of incidental or consequential damages, so the above exclusion may not apply to you.

Bock Water Heaters, Inc. • 110 South Dickinson Street • Madison, WI 53703
Telephone 608 -257-2225 • Fax 608 -257- 5304
www.bockwaterheaters.com