

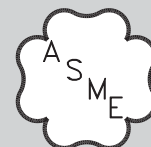


***Finned Copper Tube  
Gas Boilers (CB) &  
Water Heaters (CW)  
& Pool Heaters (CP)***

## **Boiler Manual**

***Installation and Operation  
Instructions***

Also read and follow:  
**HeatNet Control Manual**



**WARNING** This manual is intended only for use by a qualified heating installer/technician. Read and follow this manual, all supplements and related instructional information provided with the boiler. Install, start and service the boiler only in the sequence and methods given in these instructions. Failure to do so can result in severe personal injury, death or substantial property damage.

**WARNING** **Do not use the boiler during construction.** Construction dust and particulate, particularly drywall dust, will cause contamination of the burner, resulting in possible severe personal injury, death or substantial property damage. The boiler can only be operated with a dust-free air supply. Follow the instruction manual procedures to duct air to the boiler air intake. If the boiler has been contaminated by operation with contaminated air, follow the instruction manual guidelines to clean, repair or replace the boiler if necessary.

**CAUTION** Affix these instructions near to the boiler. Instruct the building owner to retain the instructions for future use by a qualified service technician, and to follow all guidelines in the User's Information Manual.

**WARNING** If the information in this manual is not followed exactly, a fire or explosion may result causing property, personal injury or loss of life.

**Do not store or use gasoline or other flammable vapors and liquids in the vicinity of this or any other appliance.**

**WHAT TO DO IF YOU SMELL GAS:**

- Do not try to light any appliance.
- Do not touch any electrical switch. Do not use any phone in your building.
- Immediately call your gas supplier from a neighbor’s phone. Follow the gas supplier’s instructions.
- If you cannot reach your gas supplier, call the fire department.

**Installation and service must be performed by a qualified installer, service agency or the gas supplier.**

**WARNING** Assurez-vous de bien suivre les instructions données dans cette notice pour réduire au minimum le risque d’incendie ou d’explosion ou pour éviter tout dommage matériel, toute blessure ou la mort

**Ne pas entreposer ni utiliser d’essence ou ni d’autres vapeurs ou liquides inflammables à proximité de cet appareil ou de tout autre appareil.**

**QUE FAIRE SI VOUS SENTEZ UNE ODEUR DE GAZ:**

- Ne pas tenter d’allumer d’appareil.
- Ne touchez à aucun interrupteur; ne pas vous servir des téléphones se trouvant dans le bâtiment.
- Appelez immédiatement votre fournisseur de gaz depuis un voisin. Suivez les intructions du fournisseur.
- Si vous ne pouvez rejoindre le fournisseur, appelez le service des incendies.

**L’installation et l’entretien doivent être assurés par un installateur ou un service d’entretien qualifié ou par le fournisseur de gaz.**

**WARNING** Failure to properly vent this unit can cause excessive amounts of carbon monoxide resulting in severe personal injury or death!

**DESIGNED AND TESTED ACCORDING TO A.S.M.E. BOILER AND PRESSURE VESSEL CODE, SECTION IV FOR A MAXIMUM ALLOWABLE WORKING PRESSURE OF 125 PSI, 862 kPa WATER.**

BEFORE YOU START . . . . . 2

RATINGS & CAPACITIES . . . . . 3

BOILER/WATER HEATER LOCATION . . . . . 3

COMBUSTION AIR & VENTILATION . . . . . 3

GENERAL VENTING GUIDELINES. . . . . 5

OUTDOOR VENTING. . . . . 10

GENERAL PIPING REQUIREMENTS . . . . . 11

HEATING SYSTEM PIPING . . . . . 12

DOMESTIC WATER SUPPLY PIPING . . . . . 16

GAS SUPPLY PIPING . . . . . 20

ELECTRICAL WIRING . . . . . 21

GENERAL OPERATION . . . . . 22

OPERATING INSTRUCTIONS . . . . . 22

SEQUENCE OF OPERATION . . . . . 25

CHECKING & ADJUSTMENTS. . . . . 26

HEATNET FIELD WIRING . . . . . 27

CONTROL DESCRIPTION . . . . . 28

DIAGNOSTIC . . . . . 28

MAINTENANCE . . . . . 31

TROUBLE-SHOOTING . . . . . 34

REPAIR PARTS. . . . . 35

START-UP SHEET . . . . . 41

MASS CODE . . . . . 43

WARRANTY . . . . . 44

**BEFORE YOU START**

This manual covers the application, installation, operation and maintenance of a Futera Series finned copper heating boiler/water heater/pool heater.

To obtain the safe, dependable, efficient operation and long life for which this heating boiler was designed, these instructions must be read, understood and followed.

The Futera Fusion Series finned copper heating boiler/water heaters have been design certified by CSA for use with natural and propane gas under the latest revision of ANSI-Z21.10.3/CSA 4.3/Gas Water Heaters, ANSI-Z21.3/CSA 4.9, Gas-fired Low Pressure Steam and Hot Water Boilers ANSI-Z21.56/CSA 4.7 Gas Fired Pool Heaters and Can 1-3.1, Industrial and Commercial Gas Fired Packaged Boilers. Each unit has been constructed and hydrostatically tested for a maximum working pressure of **125 psi, 862 kPa** in accordance with Section IV of the A.S.M.E. Boiler and Pressure Vessel Code.

All aspects of the boiler installation must conform to the requirements of the authority having jurisdiction, or, in the absence of such requirements, to the National Fuel Gas Code, ANSI Z223.1/NFPA 54-latest revision. Where required by the authority having jurisdiction, the installation must conform to the Standard for Controls and Safety Devices for Automatically Fired Boilers, ANSI/ASME CSD-1.

In Canada, the installation must be in accordance with the requirements of CSA B149.1 or .2, Installation Code for Gas Burning Appliances and Equipment.

If installed in the Commonwealth of Massachusetts, you **MUST FOLLOW** the additional instructions contained in RBI's instruction sheet MACODE-3. Which is located in the back of this manual.

The owner should maintain a record of all service work performed with the date and a description of the work done. Include the name of the service organization for future reference.

Direct all questions to your RBI distributor or contact the RBI Customer Service Department at: 260 North Elm Street, Westfield, MA 01085 for US or 7555 Tranmere Drive, Mississauga ONT L5S 1L4 for Canada. Always include the model and serial numbers from the rating plate of the boiler in question. For information utilizing the Fusion as a pool heater, see Addendum (UMPH) - Fusion Series Gas Pool Heater.

## RATINGS & CAPACITIES

Before undertaking the installation of the Futera Series boiler check the rating plate to ensure that the unit has been sized properly for the job. The "Net AHRI Ratings" specify the equivalent amount of direct copper radiation that the unit can supply under normal conditions. Also ensure that the unit has been set up for the type of gas available at the installation site. Other important considerations are the availability of an adequate electrical supply, fresh air for combustion and a suitable chimney or vent system.

## BOILER/WATER HEATER LOCATION

1. This boiler/water heater is suitable for indoor and outdoor installations. Locate the boiler/water heater in an area that provides good access to the unit. Servicing may require the removal of jacket panels. Allow the minimum clearances between adjacent construction and the boiler/water heater as listed in Table 1.

**NOTICE** Service clearances are not mandatory, but are recommended to ensure ease of service should it be required.

**Table 1**

	Clearance to Combustibles		Service Clearance	
	in	mm	in	mm
Top	6	153	30	762
Back	6	153	24	610
Left Side	6	153	24	306
Right Side	6	153	24	306
Front	6	153	30	762

2. An optimum site will be level, central to the piping system, close to a chimney or outside wall and have adequate fresh air for combustion. Ensure that the boiler is level from front to back and from side to side. Use metal shims to level the boiler. Electrical and electronic components must also be protected from exposure to water during operation and maintenance. **DO NOT** install this boiler in a location that would subject any of the gas ignition components to direct contact with water or excessive moisture during operation or servicing.
3. Ensure that the floor is structurally sound and will support the weight of the boiler.

**NOTICE** The Futera may be installed directly on combustible flooring, but never on carpeting.

4. Locate the boiler/water heater in an area that will prevent water damage to adjacent construction should a leak occur or during routine maintenance. If such a location doesn't exist, a suitable drain pan that's adequately drained must be installed under the unit.
5. **DO NOT** place this boiler/water heater in a location that would restrict the introduction of combustion air into the unit or subject it to a negative pressure, see "GENERAL VENTING GUIDELINES".
6. **NEVER** place this boiler/water heater in a location that would subject it to temperatures at or near freezing, see the "FREEZE PROTECTION" section on page 11.

**WARNING** Never store combustible materials, gasoline or any product containing flammable vapors or liquids in the vicinity of the boiler/water heater. Failure to comply with this warning can result in an explosion or fire causing extensive property damage, severe personal injury or death!

## COMBUSTION AIR & VENTILATION

**WARNING** This boiler/water heater must be supplied with combustion air in accordance with Section 5.3, Air for Combustion & Ventilation, of the latest revision of the National Fuel Gas Code, ANSI Z223.1/NFPA 54 and all applicable local building codes. Canadian installations must comply with CAN/CGA B149.1 or .2 Installation Code for Gas Burning Appliances and Equipment, or applicable provisions of the local building codes. Failure to provide adequate combustion air for this boiler/water heater can result in excessive levels of carbon monoxide which can result in severe personal injury or death!

To operate properly and safely this boiler/water heater requires a continuous supply of air for combustion. **NEVER** store objects on or around the boiler/water heater!

**CAUTION** Combustion air contaminated with fluorocarbons or other halogenated compounds such as cleaning solvents and refrigerants will result in the formation of acids in the combustion chamber. These acids will cause premature failure of the boiler voiding the warranty!

**CAUTION** If the boiler is operated while the building is under construction it **MUST** be protected from wood, concrete, sheet rock and other types of dust. Failure to properly protect the unit from construction dust will damage the unit voiding the warranty!

Buildings will require the installation of a fresh air duct or other means of providing make-up air if the intake air option isn't used. Any building utilizing other gas burning appliances, a fireplace, wood stove or any type of exhaust fan must be checked for adequate combustion air when all of these devices are in operation at one time. Sizing of an outside air duct must be done to meet the requirements of all such devices.

**WARNING** Never operate the Futera in an environment subjected to a negative pressure unless it is Direct Vented. Failure to comply with this warning can result in excessive levels of carbon monoxide causing severe personal injury or death!

### All Air From Inside The Building

If the Futera is to be located in a confined space, the minimum clearances listed in Table 1 must be maintained between it and any combustible construction. When installed in a confined space **without the intake air option**, Figures 5 and 6, two permanent openings communicating with an additional room(s) are required. The combined volume of these spaces must have sufficient volume to meet the criteria for an unconfined space. The total air requirements of all gas utilization equipment, fireplaces, wood stoves or any type of exhaust fan must be considered when making this determination. Each opening must have a minimum free area of **1 in<sup>2</sup>/1000 Btu/hr, 2200 mm<sup>2</sup>/kW** based on the total input rating of ALL gas utilization equipment in the confined area. Each opening must be no less than **100 in<sup>2</sup>, 64,516 mm<sup>2</sup>** in size. The upper opening must be within **12 in, 305 mm** of, but not less than **3 in, 76 mm** from, the top of the enclosure. The bottom opening must be within **12 in, 305 mm** of, but not less than **3 in, 76 mm** from, the bottom of the enclosure.

### All Air From Outside The Building

When installed in a confined space **without utilizing the intake air option** two permanent openings communicating directly with, or by ducts to, the outdoors or spaces that freely communicate with the outdoors must be present. The upper opening must be within **12 in, 305 mm** of, but not less than **3 in, 76 mm** from, the top of the enclosure. The bottom opening must be within **12 in, 305 mm** of, but not less than **3 in, 76 mm** from, the bottom of the enclosure.

Where directly communicating with the outdoors or communicating with the outdoors through vertical ducts, each opening shall have a minimum free area of **1 in<sup>2</sup>/4000 Btu/hr, 550 mm<sup>2</sup>/kW** of the total input rating of all of the equipment in the enclosure.

Where communicating with the outdoors through horizontal ducts, each opening shall have a minimum free area of **1 in<sup>2</sup>/2000 Btu/hr, 1100 mm<sup>2</sup>/kW** of the total input rating of all of the equipment in the enclosure.

When ducts are used, they must have the same cross-sectional area as the free area of the opening to which they connect.

When calculating the free area necessary to meet the make-up air requirements of the enclosure, consideration must be given to the blockage effects of louvers, grills and screens. Screens must have a minimum mesh size of **1/4 in, 6.4 mm**. If the free area through a louver or grill is not known, ducts should be sized per Table 2.

Canadian installations must comply with CSA B149.1 when **air supply** is provided by natural air flow from the outdoors for **natural draft**, partial fan-assisted, fan-assisted, or power draft-assisted **burners**, there shall be a permanent **air supply** opening(s) having a cross-sectional area of not less than **1 in<sup>2</sup> per 7,000 Btuh (310 mm<sup>2</sup> per kW)** up to and including **1 million Btuh**, plus **1 in<sup>2</sup> per 14,000 Btuh (155 mm<sup>2</sup> per kW)** in excess of **1 million Btuh**.

**Table 2** Make-up Air Louver Sizing

Input (MBH)	Required Cross Sectional Area					
	1/4 in 6.4 mm		75% Free Area		25% Free Area	
	Wire Screen		Metal Louvers		Wooden Louvers	
	in <sup>2</sup>	cm <sup>2</sup>	in <sup>2</sup>	cm <sup>2</sup>	in <sup>2</sup>	cm <sup>2</sup>
2500	<b>625</b>	4031	<b>833</b>	5382	<b>2500</b>	16,127
3000	<b>750</b>	4838	<b>1000</b>	6452	<b>3000</b>	19,354
3500	<b>875</b>	5645	<b>1167</b>	7522	<b>3500</b>	22,581
4000	<b>1000</b>	6452	<b>1334</b>	8592	<b>4000</b>	25,808

### Intake Air Option – General Guidelines

This configuration provides combustion air directly to the boiler's air intake adapter using a dedicated pipe when using the direct vent option. Combustion air can be drawn in horizontally through the same outside wall which terminates the exhaust gases or vertically through the roof, see Figures 1, 2, 3 & 4.

**WARNING** Common intake air systems may be used provided the common duct is sized properly. An intake combustion air damper should be installed if the common vent option is used in the intake air pipe of each heater. Improper installation can result in excessive levels of carbon monoxide which can cause severe personal injury or death!

Single wall galvanized smoke pipe, single wall aluminum pipe, flexible aluminum pipe, PVC or CPVC pipe can be used for the intake air pipe. It must be sized per Table 3.

**Table 3** Intake Air Pipe Sizing (Up to 100')

Model MBH	Vertical		Horizontal	
	in	mm	in	mm
2500/3000	10	254	8	203
3500/4000	12	305	10	254

Note: Max horizontal/vertical intake pipe 100' equivalent.

All joints in metal intake air systems must be secured using corrosion resistant fasteners and sealed using a suitable Silicone caulk. If PVC or CPVC is used, the joints must be cleaned with a suitable solvent and connected using a solvent based PVC cement. **The combustion air system MUST be supported by the building structure not the boiler/water heater.**

**CAUTION** A combustion air damper interlocked with the unit should be installed in the intake air pipe when the infiltration of subfreezing air could occur, otherwise the unit could freeze up voiding the warranty!

### Intake Air Option – Vertical Guidelines

The maximum equivalent length for the vertical intake air pipe is **100 ft, 30.5 m**. Each 90° elbow and the intake air terminal are equal to **10 linear ft, 3.0 m** of pipe, see Table 3.

An approved, nonrestrictive intake air terminal must be used. The intake air terminal must terminate as shown in Figure 3. The penetration point in the roof must be properly flashed and sealed.

### Intake Air Option – Horizontal Guidelines

The maximum equivalent length for the horizontal intake air pipe is **100 ft, 30.5 m**. Each 90° elbow and the intake air terminal are equal to **10 linear ft, 3.0 m** of pipe. If horizontal runs exceed **5 ft, 1.5 m** they must be supported at **3 ft, 0.9 m** intervals with overhead hangers. The certified intake air terminal from RBI must be used, see Figures 1, 2 and 4.

## GENERAL VENTING GUIDELINES

**WARNING** The vent installation must be in accordance with Part 7, Venting of Equipment, of the National Fuel Gas Code, ANSI Z223.1/NFPA 54-latest revision or applicable provisions of the local building codes. Canadian installations must comply with CAN/CGA B149.1 or .2 Installation Code. Improper venting can result in excessive levels of carbon monoxide which can result in severe personal injury or death!

All vent systems must be fully supported by the building structure and not by the boiler/water heater. Appropriate thimbles and fire-stops must be used where required.

**WARNING** Common vent systems must be properly engineered and sized, please contact the factory. It is required that the boiler nearest the vertical chimney be fired first when the horizontal distance exceeds 50% of the vertical distance. Refer to HeatNet manual on how to select the lead boiler.

**WARNING** A UL listed stainless steel vent system must be used unless this unit is fitted with an RBI supplied non-metallic vent kit. Failure to comply with this warning can cause excessive levels of carbon monoxide resulting in severe illness and death!

**NOTICE** For instructions utilizing the non-metallic vent option, see Addendum (FTF-PVCVO) for PVC and (FTF-PPVO) for Polypropylene.

### Vent System Options

The flue products in the vent system may be cooled below their dew point and form condensate in the flue. The materials used for a **Category IV** vent must be resistant to any corrosive damage from flue gas condensate. The flue from a **Category IV** vent system must have a condensate drain with provisions to properly collect and dispose of any condensate that may occur in the venting system.

The Futera Fusion may be vented the following ways:

- 1) **Direct Vent, Positive Pressure, Category IV** uses a vent system certified to UL 1738 for installations in the United States, ULC S636 for installations in Canada. Combustion air is piped from the outdoors to the blower inlet.
  - 2) **Side Wall Vent, Positive Pressure, Category IV** uses a vent system certified to UL 1738 for installations in the United States, ULC S636 for installations in Canada. Combustion air is obtained from the space in which the unit is installed.
- WARNING** To ensure proper operation, boilers that are vented side wall and use room air must not be fired less than 33% input.
- 3) **Vertical Vent, Positive Pressure, Category IV** uses a vent system certified to UL 1738 for installations in the United States, ULC S636 for installations in Canada. Combustion air is obtained from the outdoors or the space in which the unit is installed.
  - 4) **Vertical Vent, Negative Pressure, Category II (common venting)** requires negative pressure in vent (natural draft). Requires a metal chimney system approved for Category II venting. This method is required if common venting multiple Fusion boilers.

**NOTICE** All venting and combustion air material supplied by installer. All venting materials must be approved for the application. Consult the vent manufacturer's product literature.

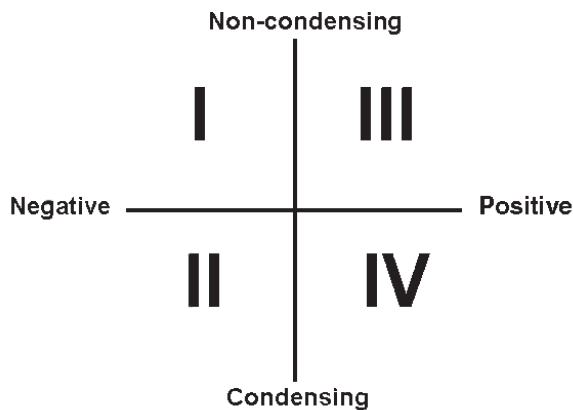
**WARNING** The maximum equivalent length for the flue outlet vent system for **Category IV** conditions is **100 ft, 30.5 m**. Use Table 4 for the equivalent lengths per fitting. Table 4 - "Category IV Equivalent Length per Fitting" chart is meant as a guideline for preliminary sizing. If vent length approaches 75% of maximum length listed, an engineered vent system calculation must be performed, consult factory.

**Table 4** Category IV Equivalent Length Per Fitting

Model/Outlet Diameter	*K	Equivalent Feet of Straight Pipe (ft)			
		CB/CW2500 8"	CB/CW3000 8"	CB/CW3500 10"	CB/CW4000 10"
Standard Tee	1.25	35 ft	35 ft	40 ft	40 ft
Boot Tee	0.65	15 ft	15 ft	20 ft	20 ft
Cap - Low Res (UL)	0.5	15 ft	15 ft	15 ft	15 ft
45° w/Bird Screen	0.4	10 ft	10 ft	15 ft	15 ft
Elbow - 90°	0.38	10 ft	10 ft	15 ft	15 ft
Elbow - 45°	0.15	5 ft	5 ft	7 ft	7 ft

\*Equivalent lengths based on listed K - factors and (5X) pipe diameters straight length between fittings.

### ANSI Categorization



**NOTICE** Must consult factory when venting single or multiple unit(s) over 100 equivalent feet. Mechanical system may be required.

### Direct Vent, Positive Pressure, Category IV

In this configuration the boiler blower is used to push the flue products to the outdoors while drawing combustion air from the outdoors. The Intake Air Option instructions under the “COMBUSTION AIR & VENTILATION” section must be followed! The vent system must be sized per Table 4.

### Horizontal Direct Vent Systems – Figures 1 & 2

The vent materials used in horizontal vent systems must be certified to UL 1738 for installations in the United States, ULC S636 for installations in Canada. The certified vent terminal from RBI must also be used.

If any part of a single wall metal vent system passes through an unheated space, it must be insulated with insulation rated for **400°F, 204°C**. Structural penetrations must be made using approved fire-stops. For best results, horizontal vent systems should be as short and straight as possible.

The vent system must be both gas tight and watertight. All seams and joints in metal pipes must be joined and sealed in accordance with the vent system manufacturer’s instructions.

When horizontal vent runs exceed **5 ft, 1.5 m** they must be supported at **3 ft, 0.9 m** intervals with overhead hangers. The vent system must be pitched down, toward the vent terminal, **1/4 in/ft, 20 mm/m**. If any part of a single wall metal vent system passes through an unheated space it must be insulated with insulation rated for **400°F, 204°C**.

Horizontal vent systems shall terminate at least **4 ft, 1.2 m** below, **4 ft, 1.2 m** horizontally from or **1 ft, 0.30 m** above any door, window or gravity air inlet into any building. It must not terminate less than **4 ft, 1.2 m** horizontally from, and in no case above or below, unless a **4 ft, 1.2 m** horizontal distance is maintained, from electric meters, gas meters, regulators and relief equipment and not less than **7 ft, 2.1 m** above adjacent public walkway. The bottom of the vent terminal(s) shall be located at least **5 ft, 1.5 m** above the air intake terminal(s) unless there is a minimum **5 ft, 1.5 m** horizontal separation between them. Avoid terminal locations likely to be affected by winds, snowdrifts, people and pets. Protect building materials and vegetation from degradation caused by the flue gases.

### Vertical Direct Vent Systems – Figure 3

If any part of a single wall metal vent system passes through an unheated space, it must be insulated with insulation rated for **400°F, 204°C**. Structural penetrations must be made using approved fire-stops.

An approved, nonrestrictive vent terminal must be used. The top of a vertical vent system must extend at least **5 1/2 ft, 1.7 m** above the roof surface and maximum snow line that it passes through, **4 ft, 1.2 m** above the intake air terminal, see Figure 3.

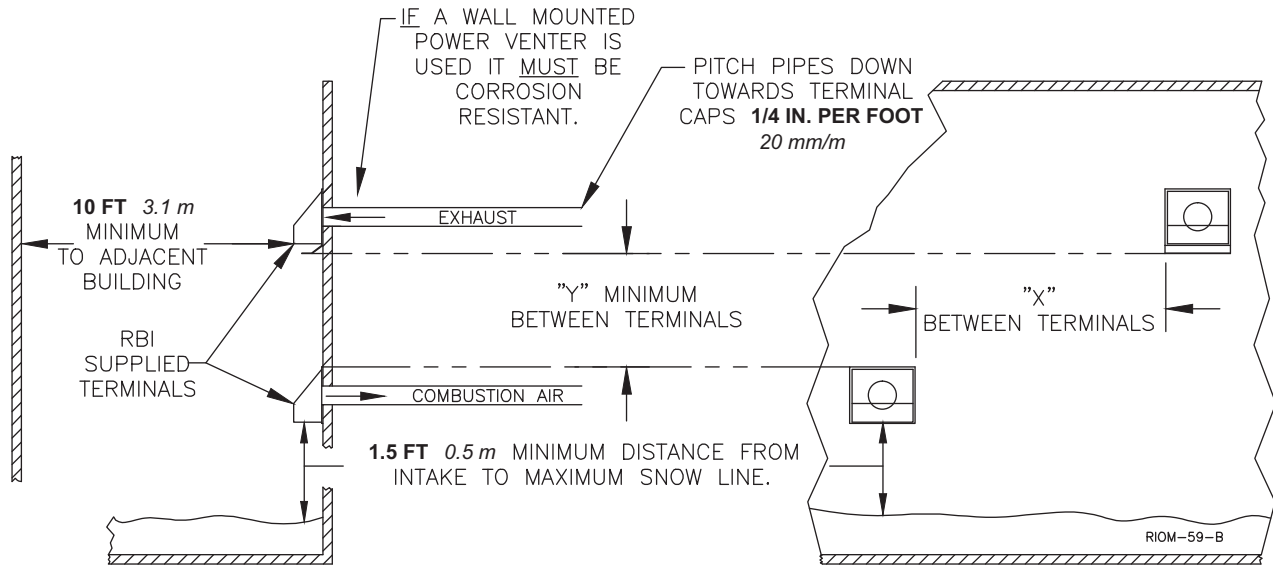
In addition the vent system must conform to the dimensions shown in Figure 3. The penetration point in the roof must be properly flashed and sealed.

The vent system must be gas tight. All seams and joints in metal pipes must be joined and sealed in accordance with the vent system manufacturer’s instructions.

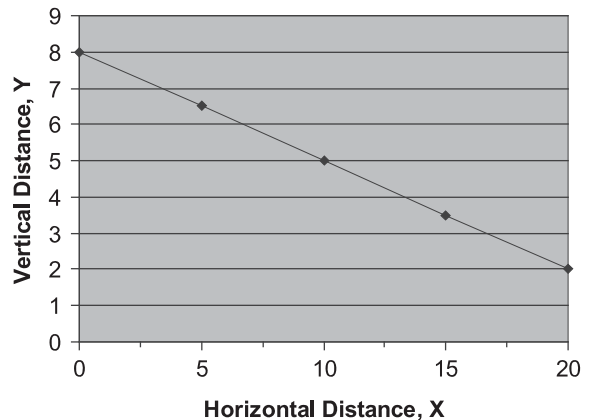
### Combination Direct Vent Systems – Figure 4

The boiler can be vented vertically with the intake air piped horizontally through an outside wall. Follow the instructions in the Intake Air Option – Horizontal Guidelines on page 5. Also follow the general instructions in the “COMBUSTION AIR & VENTILATION” and “GENERAL VENTING GUIDELINES” sections.

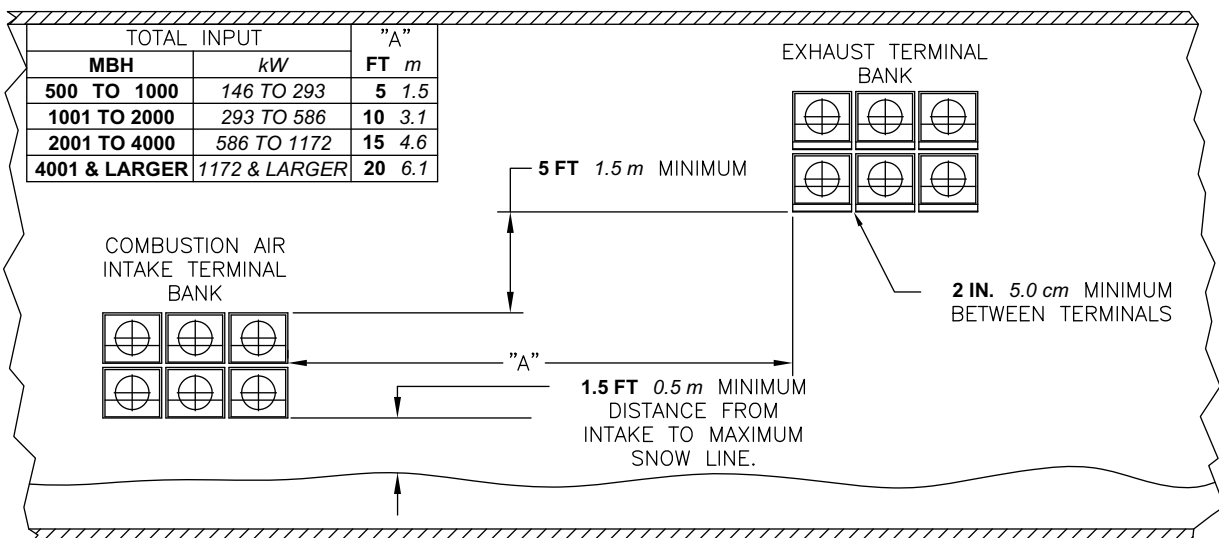
**Figure 1** Horizontal Air Intake and Venting for a Single Direct Vent System



When running horizontal combustion air and venting for single or multiple units, exhaust and combustion air terminals must be installed on the same plane (outside wall) in order to prevent pressure differences due to prevailing winds. In cold climates, double-wall or insulated inlet pipe recommended to prevent condensation.

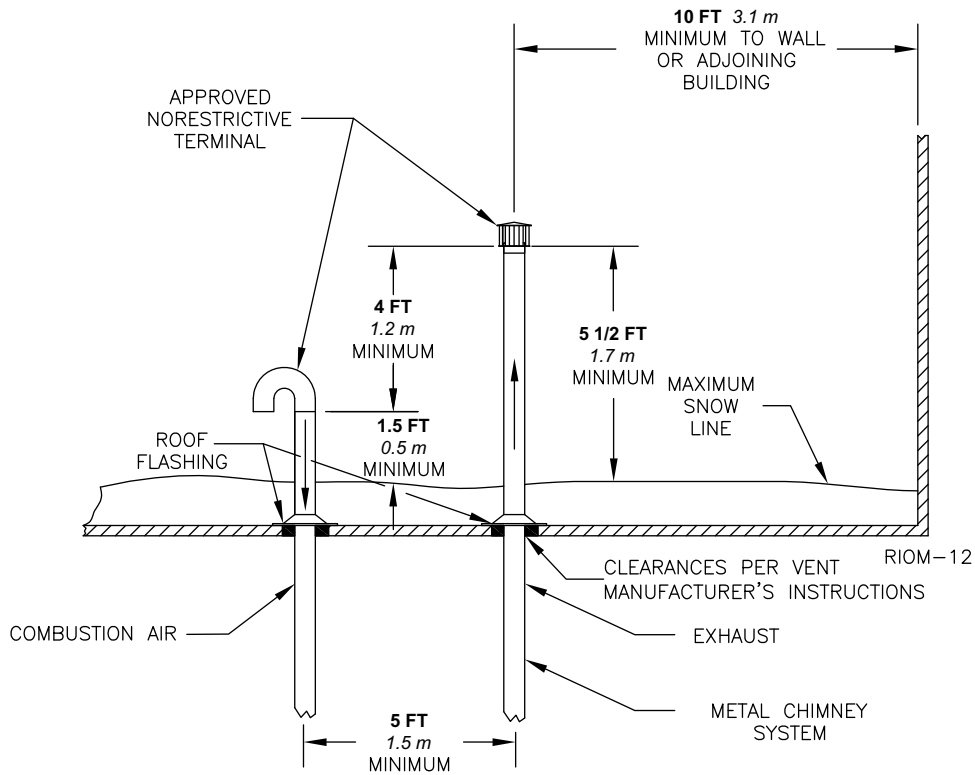


**Figure 2** Horizontal Air Intake and Venting for Multiple Direct Vent Systems

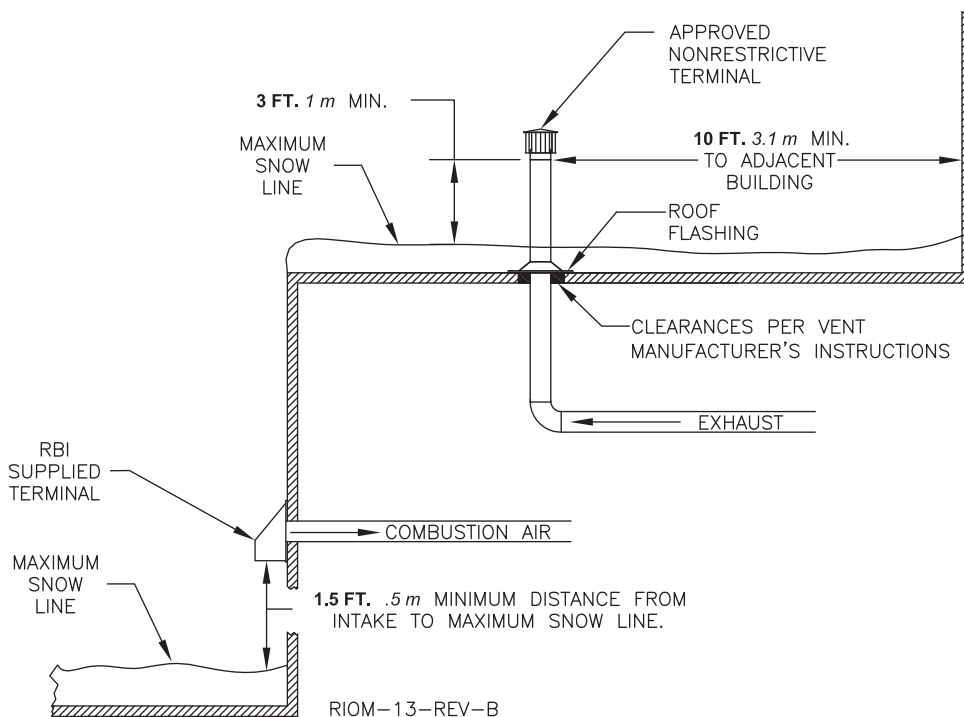


**Figure 3** Vertical Air Intake and Venting for a Direct Vent System

**NOTICE** Locate exhaust terminal downwind to reduce flue gas recirculation.



**Figure 4** Horizontal Air Intake and Venting for Multiple Direct Vent Systems

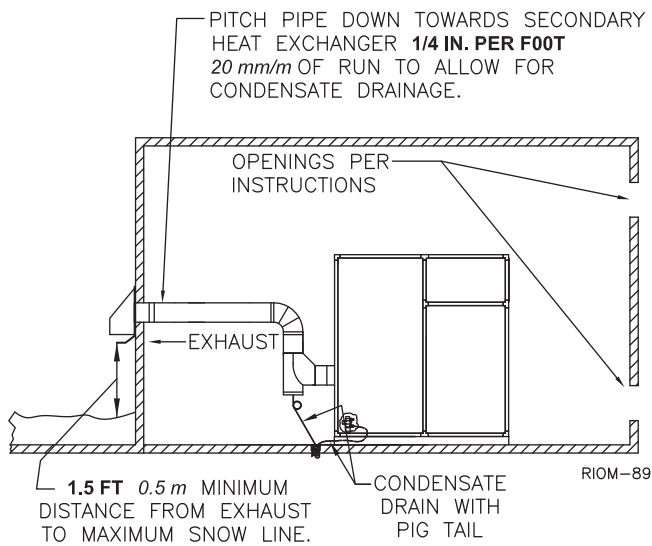




**Side Wall Vent, Positive Pressure,  
Category IV – Figure 5**

In this configuration the boiler blower is used to push the flue products horizontally to the outdoors, see Figure 5. The air for combustion is taken from the space in which the unit is installed. The applicable instructions under the “COMBUSTION AIR & VENTILATION” section must be followed! The vent guidelines under the Horizontal Direct Vent Systems section must also be followed.

**Figure 5** Side Wall Venting



**WARNING** To ensure proper operation, boilers that are vented side wall and use room air must not be fired less than 33% input.

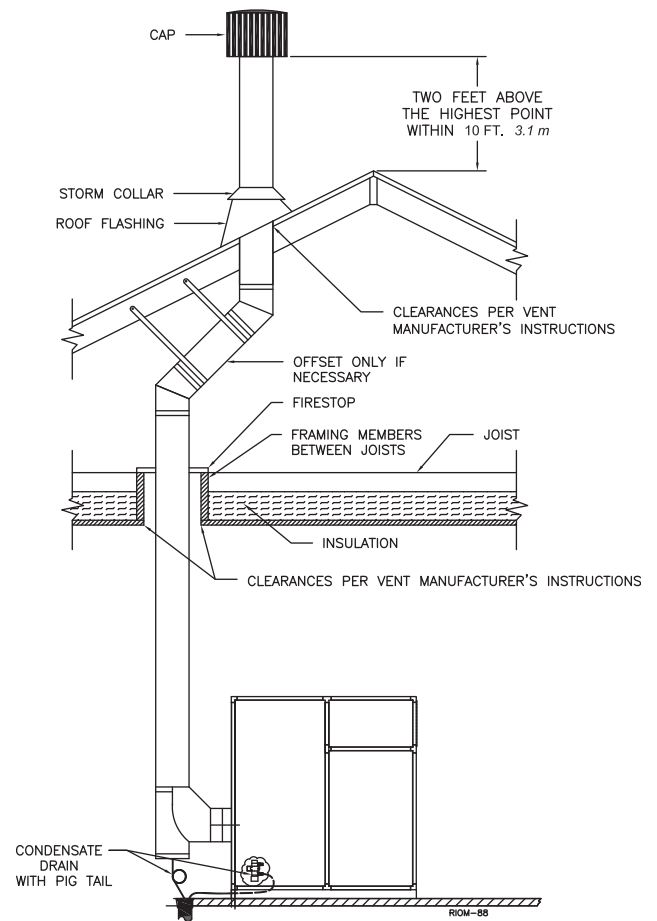
**Vertical Vent, Positive Pressure,  
Category IV – Figure 6**

(Vent pipe equivalent length up to **100 ft, 30.5 m** maximum)

**WARNING** Masonry chimneys, when used, must be lined with a metal liner certified for Category IV venting.

A through inspection of the masonry chimney must be performed to ensure that the chimney is clean, properly constructed lined, and sized. Exterior masonry chimneys should not be used unless properly lined to prevent condensation and draft problems.

**Figure 6** Vertical Venting with a Metal Chimney System  
See Table 4, page 6 for minimum pipe dimensions



VERTICAL VENTING WITH A METAL CHIMNEY SYSTEM

**Vertical Chimney Venting  
Negative pressure — Category II  
(Common Venting)**

**WARNING** Category II venting is required for multiple Fusion XLF boilers connected to a common vent. Common vent systems cannot be pressurized.

The Fusion XLF is listed as a Category II appliance when vented vertically into a listed metal chimney system. The chimney must provide a negative pressure not greater than **0.10 in, 2.5 mm WC** at the boiler flue collar with the unit running.

**NOTICE** When using a listed metal chimney system the chimney system manufacturer’s instructions must be followed.

**WARNING** The vent piping must be large enough to safely vent the combined output of all of the appliances connected to the system.

If an appliance using any type of a mechanical draft system operating under positive pressure is connected to a chimney flue, never connect any other appliances to this flue. Doing so can result in excessive levels of carbon monoxide which can cause severe personal injury or death!

### Category II Chimney Inspection & sizing

**WARNING** Masonry chimneys, when used, must be lined with a metal liner certified for Category IV venting.

A thorough inspection of the masonry chimney must be performed to ensure that the chimney is clean, properly constructed, lined and sized. Exterior masonry chimneys should not be used unless properly lined to prevent draft problems.

Table 5 lists the minimum riser sizes required for the Fusion boiler.

**Table 5** Riser Diameters To Common Vent For Category II Venting

Input MBH	in	mm
2500/3000	12	305
3500/4000	14	356

Note: These sizes are based on a **20 ft, 6.1 m** chimney height.

### Category II Vent Connections

Locate the boiler as close to the chimney as possible. Use the shortest, straightest vent connector possible for the installation. If horizontal runs exceed **5 ft, 1.5 m** they must be supported at **3 ft, 0.9 m** intervals with overhead hangers.

The boiler vent connectors should be sloped up toward the breeching at a minimum rate of **1/4 in per ft, 21 mm per m**.

Always provide a minimum clearance of **6 in, 152 mm** between single wall vent pipe and any combustible materials.

**WARNING** Failure to maintain minimum clearances between vent connectors and any combustible material can result in a fire causing extensive property damage, severe personal injury or death!

### Vent Connections

Locate the boiler as close to the chimney as possible. Use the shortest, straightest vent connector possible for the installation. If horizontal runs exceed **5 ft, 1.5 m** they must be supported at **3 ft, 0.9 m** intervals with overhead hangers.

The vent connector should be sloped up toward the chimney at a minimum rate of **1/4 in/ft, 21 mm/m**. On masonry chimneys the connector must terminate flush with the inside of the chimney flue.

Always provide a minimum clearance of **6 in, 152 mm** between single wall vent pipe and any combustible materials.

Exit cones are favorable when used to increase the velocity of the flue gas exiting the stack and, may also help, in cold climates, to reduce ice build-up. Exit cone terminations must be supplied by others, installed per manufacturer's instructions, and meet local and federal code.



generic exit cone

**NOTICE** When using a listed metal chimney system the chimney system manufacturer's instructions must be followed.

**WARNING** Failure to maintain minimum clearances between vent connectors and any combustible materials can result in a fire causing extensive property damage severe personal injury or death!

## OUTDOOR VENTING

When installed outdoors the Futera Fusion must be fitted with the factory supplied outdoor hood, air intake adapter with filter and exhaust terminal, see Figure 7. Multiple units must be spaced per Figure 8.

The boiler/heater must be at least **2 ft, .62 m** from any door, window or gravity air inlet into any building and at least **3 ft, 1 m** from any overhang unless local codes dictate differently.

Avoid locations where wind deflection off of adjacent walls, buildings or shrubbery might cause a downdraft. The unit(s) should be located at least **3 ft, 1 m** from structures. Outdoor installations are not recommended in areas where the danger of snow blockage exists.

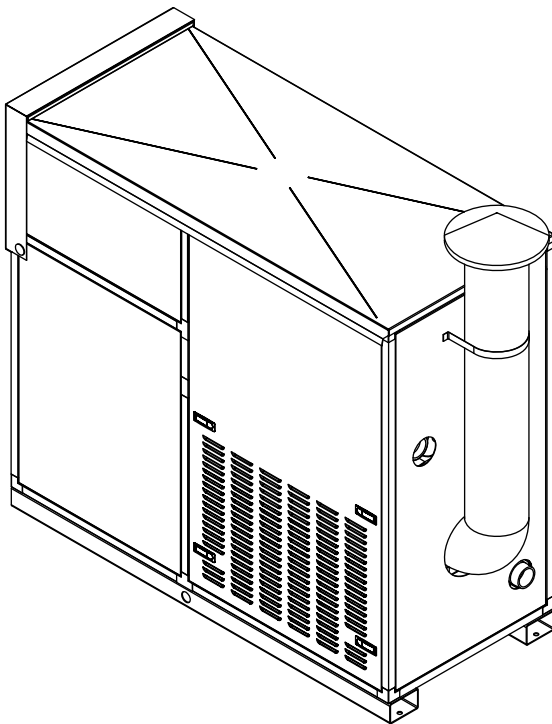
**CAUTION** Do not place the boiler/water heater in a location that would subject it to runoff from adjacent buildings or damage may occur voiding the warranty!

### Outdoor Installations

**WARNING** The Futera Boiler is certified for outside installations in temperate climates only.

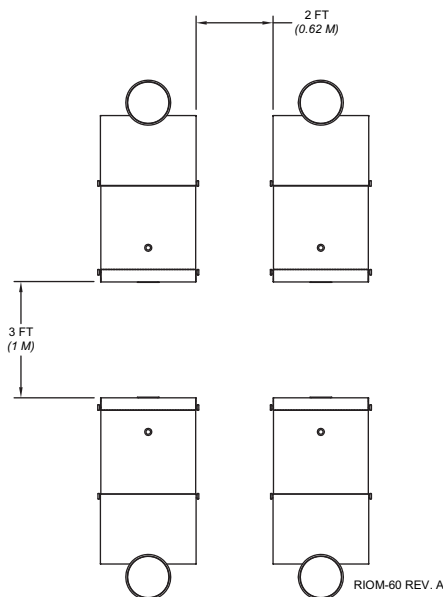
1. The condensate traps located under the secondary heat exchanger and the vent pipe must be wrapped with heat tape to ensure the traps never drop below 32°F.
2. The vent pipe must be insulated to prevent freezing of condensate in the pipe.
3. The boiler and system must be filled with an ethylene glycol/water antifreeze mixture not to exceed 50% glycol by volume.
4. All water piping exposed to low temperatures must be insulated.

**Figure 7** Outdoor Venting



RIOM-86

**Figure 8** Multiple Outdoor



## GENERAL PIPING REQUIREMENTS

**CAUTION** Improper piping of this boiler will void the manufacturer's warranty and can cause boiler failure resulting in flooding and extensive property damage! Excessive water hardness causing scaling in the copper heat exchanger tubes is NOT covered under the manufacturer's warranty, see Table 8. Excessive pitting and erosion of the internal surface of the copper heat exchanger tubes is NOT covered under the manufacturer's warranty if the result of high water flow rates.

**NOTICE** Shut off valves and unions should be installed at the inlet and outlet connections of the boiler to provide for isolation of the unit should servicing be necessary.

### Freeze Protection

Installations in areas where the danger of freezing exists are not recommended unless proper freeze protection is provided. The following precautions MUST be observed:

1. A continuous flow of water through the unit MUST be maintained! The pump responsible for flow through the boiler must run continuously!
2. An ethylene glycol/water mixture suitable for the minimum temperature that the unit will be exposed to must be used. The boiler on board pump is capable of producing the required flow for systems maintaining a maximum 30% glycol water mixture. For mixtures higher than 30% ethylene glycol please contact factory. Domestic water systems must be isolated from the water heater by the use of a heat exchanger or other approved method.
3. If the unit must be shut off for any reason the electric, gas and water supplies MUST be shut off and the unit and its pump completely drained.

**CAUTION** Improper outdoor installation of this unit can cause boiler failure voiding the manufacturer's warranty!

### Condensate Piping

The condensate trap provided with the boiler must be attached to the bottom pan and piped to a suitable floor drain or condensate pump. If a condensate neutralization device is installed, it must be positioned prior to boiler room drain. Condensate fill trap must be maintained with fluid.

### Relief Valve

Pipe the discharge of the pressure relief valve as shown in Figure 9.

**WARNING** Never install any type of valve between the boiler and the relief valve or an explosion causing extensive property damage, severe personal injury or death may occur!

## Flow Switch

The flow switch supplied with the boiler must be wired to the terminal strip in the control panel to prevent the boiler from firing unless there's adequate water flow through the unit. The flow switch must be installed in the supply piping adjacent to the boiler outlet connection.

**CAUTION** Failure to properly install the flow switch may result in damage to the boiler heat exchanger voiding the warranty!

## HEATING SYSTEM PIPING

### General Piping Requirements

All heating system piping must be installed by a qualified technician in accordance with the latest revision of the ANSI/ASME Boiler and Pressure Vessel Code, Section IV, and ANSI/ASME CSD-1, Standard for Controls and Safety Devices for Automatically Fired Boilers. All applicable local codes and ordinances must also be followed. A minimum clearance of **1 in, 25 mm** must be maintained between heating system pipes and all combustible construction. All heating system piping must be supported by suitable hangers not the boiler. The thermal expansion of the system must be considered when supporting the system. A minimum system pressure of **12 psig, 82.7 kPa** must be maintained.

### Bleed Air From Boiler

Open the boiler piping bleed valves one at a time, to purge the air trapped in the primary and secondary heat exchangers. Refer to piping drawings (Figures 7, 8 & 9) for bleed locations.

### Heating Boiler Piping Connections

The supply and return connections should be sized to suit the system, see Table 6.

**Table 6** Supply & Return Pipe Sizing

Input MBH	Supply Size	Return Size
2500 thru 4000	3 in FLANGE	3 in FLANGE

**NOTICE** Pump sizing based on the following: total boiler head loss plus 30 feet of piping and a maximum of six (6) 90° elbows and based on supply and return pipe diameter of 3" on 2500-3000 and 4" on 3500-4000.

## Pump Requirements

This low mass boiler requires a continuous minimum water flow across the primary heat exchanger for proper operation. The boiler pump is sized to overcome the head loss of the boiler primary and secondary heat exchanger and the near piping in order to achieve the required flow. The temperature rise across the primary heat exchanger must never exceed **35°F, 19.4°C**. See Tables 8 and 9 for the total boiler recovery rate (gph) and inlet/outlet delta t based on the desired boiler inlet temperature. The adjustable pump delay turns the pump on each time the burner fires and runs the pump for 20 to 600 seconds after the call for heat is satisfied.

**CAUTION** The maximum allowable primary heat exchanger temperature rise is **35°F, 19.4°C**.

### Factory Supplied - On Board - Circulating Pump

The factory installed - on board - pump is sized to work the total boiler head loss plus an additional (30 ft) of pipe and (6 elbows). Please consult factory for systems outside these parameters.

### Low Water Cutoff

If a boiler is installed above any radiation elements it must be fitted with a low water cutoff device.

Refer to the wiring diagram supplied with the boiler for proper wiring connections.

### Expansion Tank & Air Separator

An expansion tank or other means to control thermal expansion must be installed in the heating system. An expansion tank must be installed close to the boiler on the suction side of the pump. An air scoop and automatic air vent must also be installed to eliminate air trapped in the system.

### Primary/Secondary Piping

Figure 10 shows a typical primary/secondary piping system. Boilers connected to heating systems using zone valves, zone pumps, or systems that have excessive flow rates must be isolated from these systems to protect the boiler.

### Multiple Boiler Systems

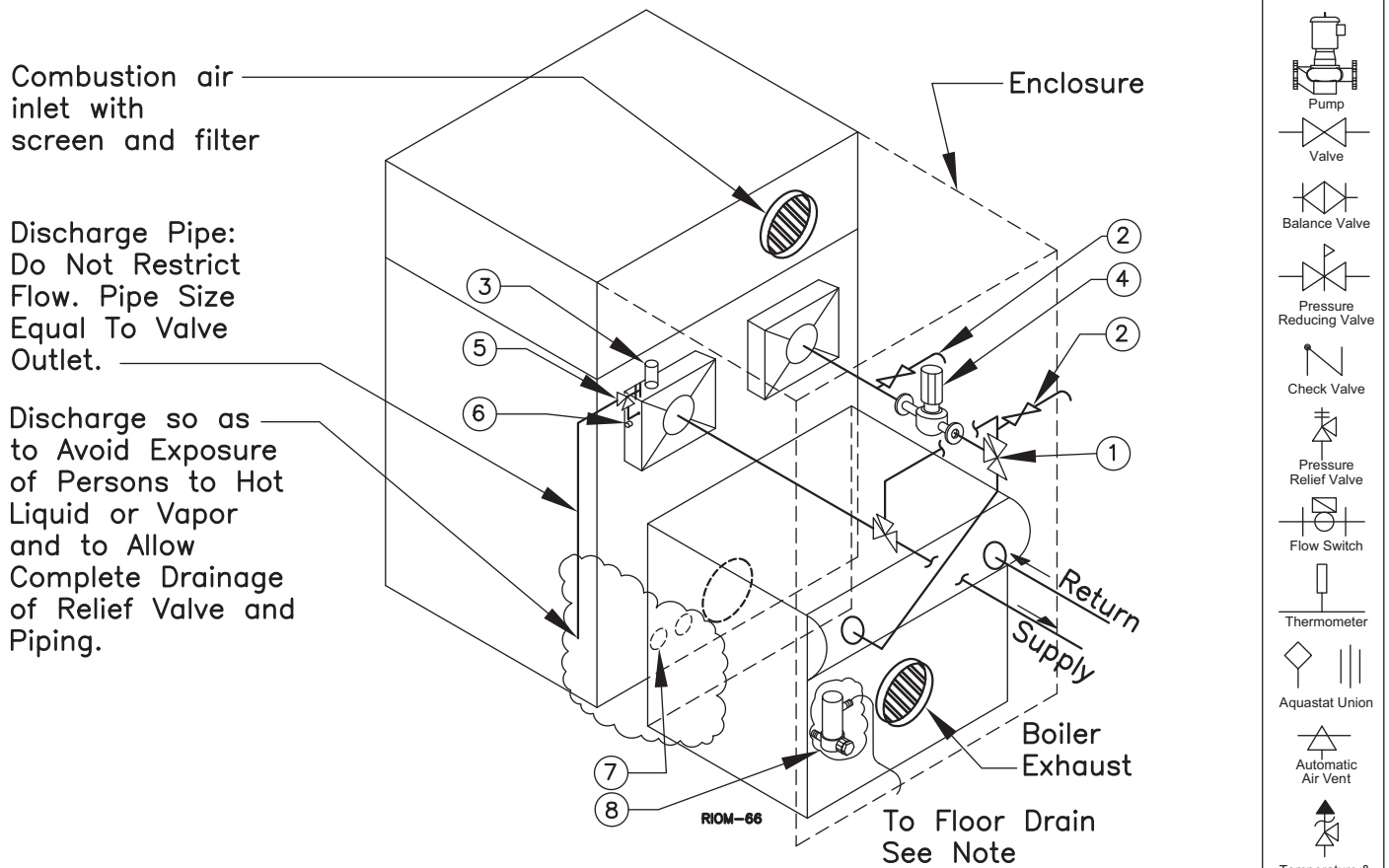
Systems using multiple boilers can also be installed using a primary/secondary manifold system, Figure 11.

### Piping For Use With Cooling Units

The boiler, when used in connection with a refrigeration system, must be installed so the chilled medium is piped in parallel with the boiler. Appropriate valves must be used to prevent the chilled water from entering the boiler.

When a boiler is connected to a heating coil that may be exposed to refrigerated air from an air handling device, the piping system must be equipped with flow-control valves or some other automatic means of preventing gravity circulation of the boiler water during the cooling cycle.

**Figure 9** Fusion XLF Secondary Bypass Piping

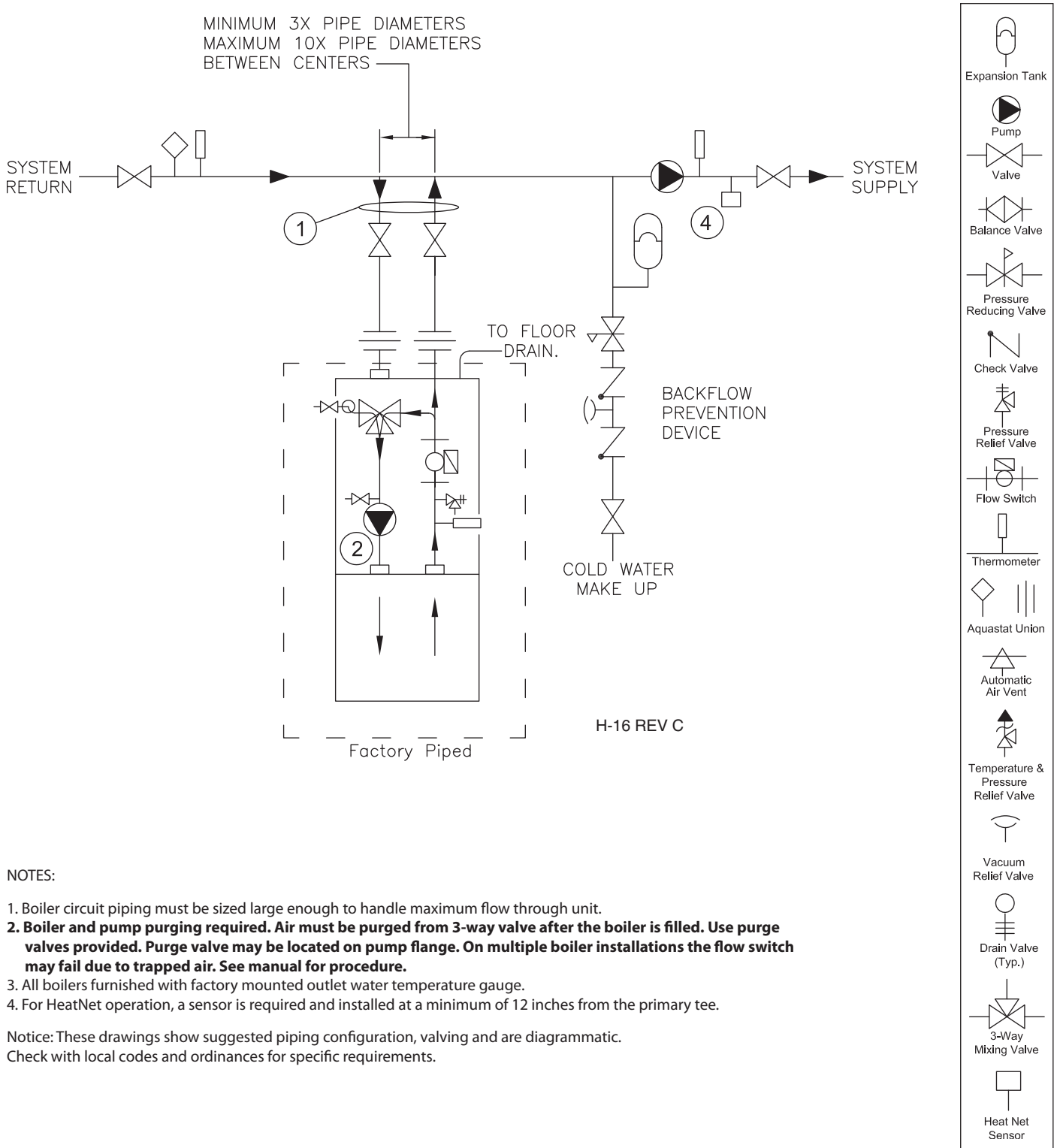


Item Number	Description
1	3-Way Valve
2	Air Purging Valves
3	Flow Switch
4	Circulator
5	Pressure Relief Valve
6	T & P Gauge
7	Primary Heat Exchanger Drain Valves
8	Condensate Drain Trap

**Notes:**

1. Fill condensate drain trap with water or approved anti-freeze solution prior to start up.
2. Air purging valve may be located on pump flange.

**Figure 10** Typical Primary/Secondary, Low Temperature Piping System (See Notes)

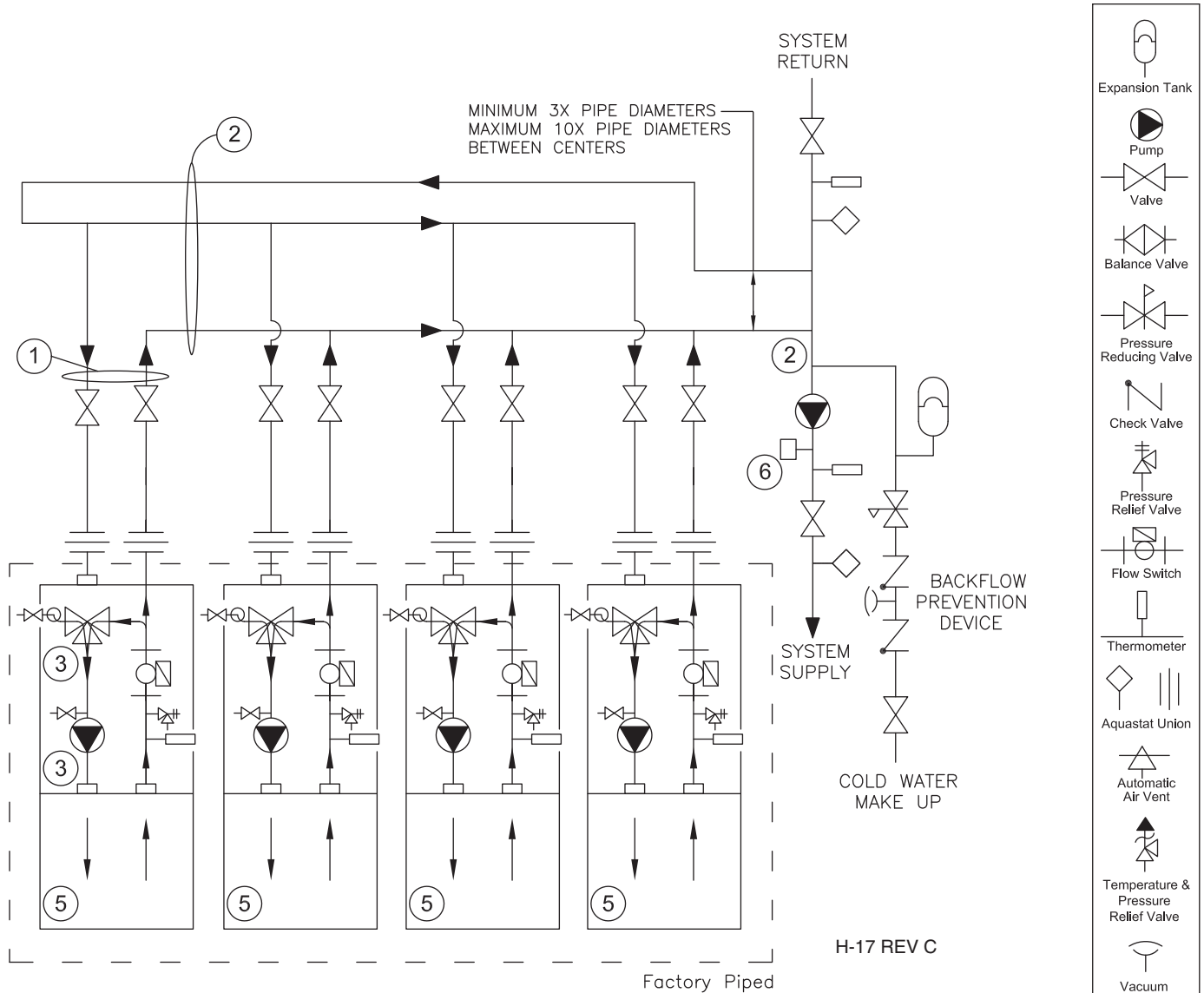


**NOTES:**

1. Boiler circuit piping must be sized large enough to handle maximum flow through unit.
2. **Boiler and pump purging required. Air must be purged from 3-way valve after the boiler is filled. Use purge valves provided. Purge valve may be located on pump flange. On multiple boiler installations the flow switch may fail due to trapped air. See manual for procedure.**
3. All boilers furnished with factory mounted outlet water temperature gauge.
4. For HeatNet operation, a sensor is required and installed at a minimum of 12 inches from the primary tee.

Notice: These drawings show suggested piping configuration, valving and are diagrammatic. Check with local codes and ordinances for specific requirements.

**Figure 11** Multiple Boiler Piping (See Notes)



**NOTES:**

1. Boiler circuit piping must be sized large enough to handle maximum flow through each unit.
2. System loop pipe diameter must be sized large enough to handle maximum flow through all units.
3. **Boiler and pump purging required. Air must be purged from 3-way valve after the boiler is filled. Use purge valves provided. Purge valve may be located on pump flange. On multiple boiler installations the flow switch may fail due to trapped air. See manual for procedure.**
4. All boilers furnished with factory mounted outlet water temperature gauge.
5. Condensate lines on each unit should be connected to a floor drain.
6. For HeatNet operation, a sensor is required and installation at a minimum of 12 inches from primary loop tee.

Notice: These drawings show suggested piping configuration, valving and are diagrammatic. Check with local codes and ordinances for specific requirements.

## DOMESTIC WATER SUPPLY PIPING

**CAUTION** Proper controls must be used to prevent water supplied for domestic use from exceeding **130°F, 54°C** or a scald injury will occur! When higher water temperatures are required for appliances such as a dishwasher, a mixing valve or some other tempering means must be installed. Households with small children may require water temperature less than **120°F, 49°C**. Local codes must be complied with!

### General Piping Requirements

The Fusion XLF boiler can be used in combination with an indirect tank to provide hot water for domestic use. Piping and components must be suitable for use with potable water. The indirect storage tank must be equipped with a temperature and pressure relief valve that complies with ANSI Z21.22 or CAN-4.4 and CAN-4.6.

**NOTICE** The storage tank must be located as close to the unit heater as possible to prevent excessive head loss which will reduce flow.

### Bleed Air From Unit Heater

Open the unit heater piping bleed valves one at a time, to purge the air trapped in the primary and secondary heat exchangers. Refer to piping drawings (Figures 10 & 11) for bleed locations.

### Water Chemistry

The required temperature rise across the primary heat exchanger is based on water having a hardness between 8 and 18 grains per gallon with a level of dissolved solids not exceeding 350 ppm. Water having a hardness less than 8 grains can cause excessive corrosion of the heat exchanger. Water that has a hardness greater than 18 grains per gallon and/or a level of dissolved solids exceeding 350 ppm will require a recalculation of the pump size and temperature rise.

A cupro-nickel primary heat exchanger may also be required. The manufacturer should be consulted when these water conditions are encountered. See Table 7.

RBI water heaters are designed to run scale free. Due to the extreme variables of water conditions world wide it is necessary to consider pH values and water hardness in relationship to scaling. It is crucial to consider these two variables when making heat exchanger and pump selections. If local water conditions are extreme, follow the guidelines in the Heat Exchanger Selection Table 7. Scale free operation can be achieved by using water with a hardness between 8 and 18 and by maintaining the pH between 5 and 9. Follow the conditions listed under NORMAL in the table. In some areas of the country additional precautions must be observed due to unusual characteristics of the local water supply. Call the nearest RBI representative for details.

### Expansion Tank

An expansion tank or other means to control thermal expansion must be installed in the water heating system if back flow prevention devices are installed.

### Pump Requirements

This low-mass water heater requires a continuous minimum water flow for proper operation. The proper velocity through the unit heater must be maintained for efficient operation and long life. If the temperature rise through the primary heat exchanger is lower than recommended the water velocity is too high. Premature erosion of the primary heat exchanger will occur. Conversely, if the temperature rise is too high, the flow rate is too low. Scaling and softening of the primary heat exchanger will occur. **The temperature rise across the primary heat exchanger must never exceed 35°F, 19.4°C.**

**CAUTION** The factory mounted circulatory pump is sized to work the total boiler pressure drop and an additional 30 ft. of pipe and 6-90° elbows.

### Storage Tank Thermostatic Mixing Valve

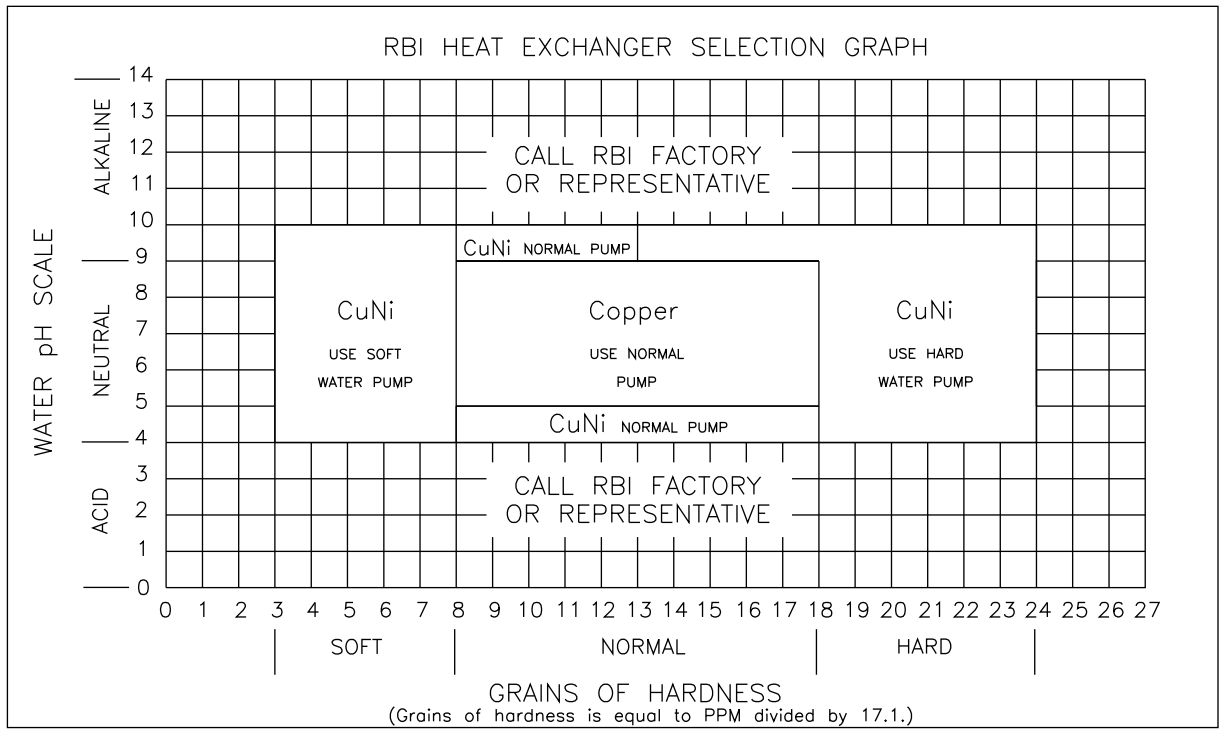
Water can be stored at temperatures above **140°F, 60°C** provided that a thermostatically controlled mixing valve is used to temper the hot water to an acceptable temperature before it's supplied for domestic use.

The mixing valve **MUST** be set to prevent a scald injury from occurring, see the caution against scalding.

Storage of water for domestic use above **140°F, 60°C** will provide an increased quantity of tempered water and help prevent the growth of water born bacteria.



**Table 7** Futera Fusion Primary Heat Exchanger Selection Graph



Copyright Pending, MESTEK 12/03

**For hard/soft water pump selection, must consult factory.**

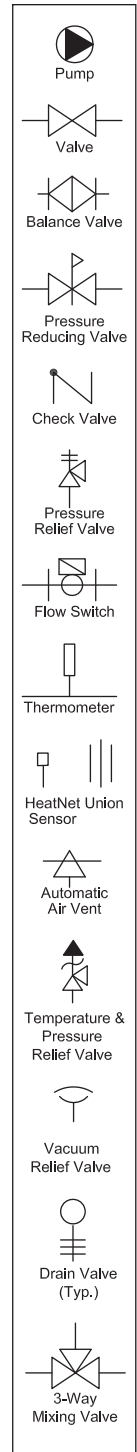
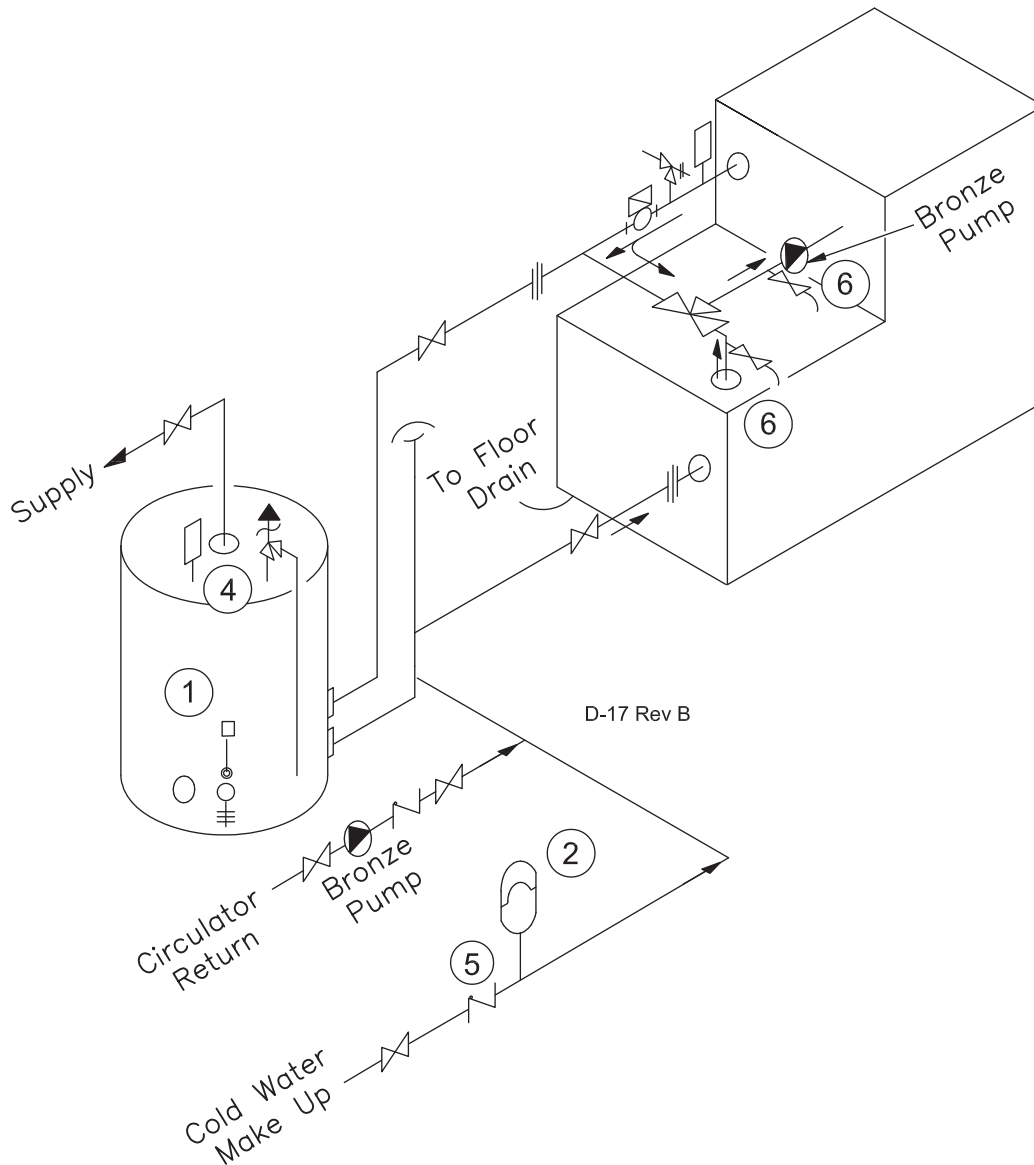
**Table 8** Delta T/Boiler Recovery Table - Fahrenheit

Inlet Temp (deg f)	Model							
	2500		3000		3500		4000	
	Flow Rate (gph)	Δt (deg f)	Flow Rate (gph)	Δt (deg f)	Flow Rate (gph)	Δt (deg f)	Flow Rate (gph)	Δt (deg f)
60	2794	105	3171	111	3700	111	4228	111
80	3316	85	3717	91	4337	91	4956	91
100	4203	65	4617	71	5386	71	6156	71
120	5903	45	6250	51	7292	51	8334	51
140	10,457	25	9804	32	11,438	32	13,072	32

**Table 9** Delta T/Boiler Recovery Table - Centigrade

Inlet Temp (deg c)	Model							
	2500		3000		3500		4000	
	Flow Rate (l/h)	Δt (deg c)	Flow Rate (l/h)	Δt (deg c)	Flow Rate (l/h)	Δt (deg c)	Flow Rate (l/h)	Δt (deg c)
16	10,560	58	11,987	62	13,984	62	15,982	62
27	12,536	47	14,051	51	16,393	51	18,735	51
38	15,886	36	17,452	39	20,360	39	23,269	39
49	22,314	25	23,627	28	27,564	28	31,502	28
60	39,529	14	37,058	18	43,234	18	49,411	18

**Figure 12** Typical Unit Heating Piping (See Notes)

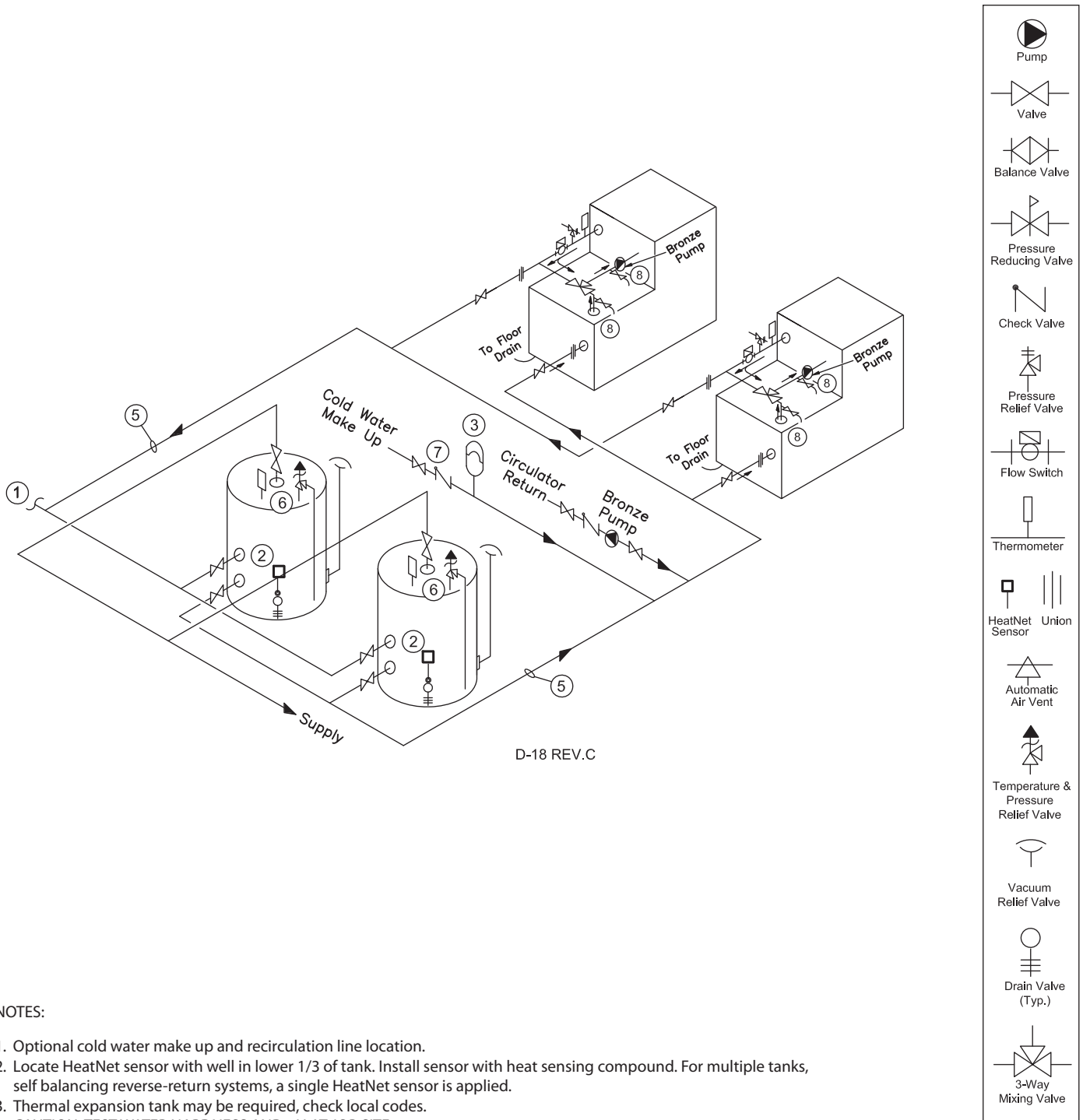


**NOTES:**

1. Locate HeatNet sensor with well in lower 1/3 of tank. Install sensor with heat sensing compound.
2. Thermal expansion tank may be required, check local codes.
3. **CAUTION: MEASURE WATER HARDNESS AND pH AT JOB SITE.**  
Be sure to specify when ordering the pH and water hardness. This must be measured before selecting heat exchanger and pump. Consult the Heat Exchanger Graph before making selection.
4. Hot water tanks should be equipped with a combination temperature & pressure relief valve.
5. MA Code requires an 1/8 in hole in check valve to compensate for thermal expansion.
6. **Boiler and pump purging required. Air must be purged from 3-way valve after the boiler is filled. Use purge valves provided. Purge valve may be located on pump flange. On multiple boiler installations the flow switch may fail due to trapped air. See manual procedure.**

Notice: These drawings show suggested piping configuration and valving. Check with local codes and ordinances for specific requirements.

**Figure 13** Multiple Unit Heating Piping (See Notes)



**NOTES:**

1. Optional cold water make up and recirculation line location.
2. Locate HeatNet sensor with well in lower 1/3 of tank. Install sensor with heat sensing compound. For multiple tanks, self balancing reverse-return systems, a single HeatNet sensor is applied.
3. Thermal expansion tank may be required, check local codes.
4. **CAUTION: TEST WATER HARDNESS AND pH AT JOB SITE.**  
Be sure to specify when ordering the pH and water hardness. This must be measured before selecting heat exchanger and pump. Consult the Heat Exchanger Graph before making selection.
5. Common piping must be sized for maximum combined heater flow.
6. Hot water tanks should be equipped with a combination temperature & pressure relief valve.
7. MA Code requires an 1/8 in hole in check valve to compensate for thermal expansion.
8. **Boiler and pump purging required. Air must be purged from 3-way valve after boiler is filled. Use purge valves provided. Purge valve may be located on pump flange. On multiple boiler installations the flow switch may fail due to trapped air. See manual procedure.**

Notice: These drawings show suggested piping configuration and valving. Check with local codes and ordinances for specific requirements.

## GAS SUPPLY PIPING

**WARNING** Check the boiler rating plate to make sure that the boiler is for the type of gas that will be used. If it isn't, do not connect the boiler to the gas supply. Gas supply piping must be in accordance with the National Fuel Code, ANSI Z223.1-latest revision or applicable provisions of the local building codes. Canadian installations must comply with CAN/CGA B149.1 or .2 Installation Code. Failure to comply with this warning can result in extensive property damage, severe personal injury or death!

The Futera Fusion XLF comes from the factory ready to be piped to the gas supply. If for any reason the boiler is not for the type of gas available at the installation site, call your RBI representative to resolve the problem.

**NOTICE** A minimum gas supply pressure of **3.5 in, 88.9 mm**, WC natural or propane and maximum **14 in, 356 mm** WC natural or propane, must be available at the safety shutoff valve inlet with the unit(s) operating, and not to exceed a maximum of a **(1.0 in WC)** drop when firing from minimum input to full load of the gas supply line and all the appliances running.

Table 10 should be used to ensure that the gas supply piping is sized properly. If more than one appliance is supplied by the same supply pipe, the piping must be sized based on the maximum possible demand. Do not neglect the pressure drop due to pipe fittings. Table 10 should be used in conjunction with Table 10 to ensure that the gas supply piping has the capacity to meet the demand.

Figure 14 depicts the proper way to connect the boiler to the gas supply piping. The manual shut-off valve **MUST** be installed in the supply piping. It should be installed **5 ft, 1.5 m** above the floor where required by local codes. Provide a sediment trap at the bottom of the vertical section of the gas supply pipe upstream of the gas controls.

A ground joint union should be installed between the boiler gas controls and the supply piping. Each of these items are needed to ensure long life and ease of servicing. Always use a pipe sealant that is suitable for use with LP gas.

**Table 10** Gas Pipe Capacity

Maximum pipe capacity in ft <sup>3</sup> /hr based on 0.60 specific gravity natural gas at a pressure of 0.5 psig or less and a 0.3" WC pressure drop, for iron pipe with nominal size below, and for total equivalent length (in feet):					
Pipe Size	Pipe length in feet				
	10	20	30	40	50
Maximum gas volume of pipe, (ft <sup>3</sup> /hr)					
2"	3050	2100	1650	1450	1270
2 1/2"	4800	3300	2700	2300	2000
3"	8500	5900	4700	4100	3600
4"	17,500	12,000	9700	8300	7400
5"	31,700	21,800	17,500	15,000	13,300
6"	51,300	35,300	28,300	24,200	21,500

Pipe Size	Pipe length in feet				
	60	70	80	90	100
Maximum gas volume of pipe, (ft <sup>3</sup> /hr)					
2"	1150	1060	990	928	870
2 1/2"	1850	1690	1600	1480	1400
3"	3250	3000	2800	2610	2500
4"	6800	6110	5800	5330	5100
5"	12,000	11,100	10,300	9650	9110
6"	19,500	17,900	16,700	15,600	14,800

Pipe Size	Pipe length in feet				
	125	150	175	200	250
Maximum gas volume of pipe, (ft <sup>3</sup> /hr)					
2"	777	710	648	602	534
2 1/2"	1240	1130	1030	960	851
3"	2190	2000	1820	1700	1500
4"	4460	4100	3720	3460	3070
5"	8090	7320	6730	6260	5550
6"	13,100	11,900	10,900	10,100	8990

Note: For propane piping — Multiply the gas volume above by 0.62 for propane flow capacities in ft<sup>3</sup>/hr. Multiply the propane flow capacity by 2500 Btu/ft<sup>3</sup> to determine the propane Btu/hr capacity for a given pipe size and length.

**Table 11** Equivalent Pipe Length Chart

Nominal Iron Pipe Size	Fitting or valve			
	90° Elbow	Tee (branch flow)	Gate Valve	Gas Cock
	Equivalent pipe length, (ft)			
2"	5.2	10.3	1.2	3.0
2 1/2"	6.2	12.3	1.4	3.5
3"	7.7	15.3	1.8	4.5
4"	10.1	20.2	2.4	6.0
5"	12.6	25.2	2.9	7.3
6"	15.2	30.4	3.5	13.4

Equivalent lengths above are for threaded fittings. Multiply values above by 0.75 for flanged fittings.

**CAUTION** Always use a wrench on the gas valve body when making gas connections to it. Never over-tighten the piping entering the gas valve body or gas valve failure may result!

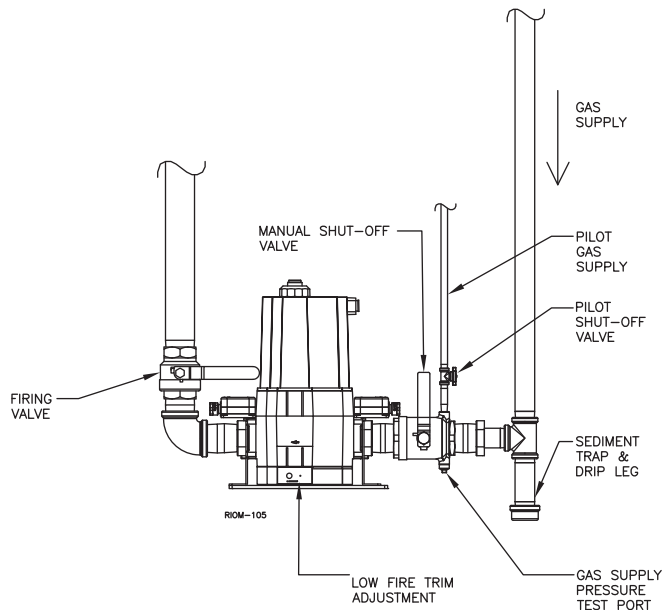
When applicable, provisions for vent, bleed and gas relief lines must be made in accordance with the latest revision of ANSI Z223.1/NFPA 54. The main Dungs gas valve supplied with boiler does not require external venting.

Safe lighting and other performance criteria were met with the gas manifold and control assembly provided on the boiler. All gas connections **MUST** be leak tested before putting the boiler into operation.

**WARNING** Never use an open flame to test for gas leaks. Always use an approved leak detection method. Failure to comply with this warning can cause extensive property damage, severe personal injury or death!

Whenever the gas supply piping is pressure tested the boiler gas controls must be protected. If the test pressure is equal to, or less than **1/2 psig, 3.5 kPa** isolate the boiler by closing its manual shut off valve, see Figure 16. If the test pressure is greater than, or equal to **1/2 psig, 3.5 kPa**, disconnect the boiler and its individual shut-off valve.

**Figure 14** Gas Supply Piping



## ELECTRICAL WIRING

### Electrical Power Connections

**CAUTION** Label all wires prior to disconnection when servicing controls. Wiring errors can cause improper and dangerous operation! Verify proper operation after servicing.

**CAUTION** Au moment de l'entretien des commandes, étiquetez tous les fils avant de les débrancher. Des erreurs de câblage peuvent entraîner un fonctionnement inadéquat et dangereux. S'assurer que l'appareil fonctionne adéquatement une fois l'entretien terminé.

The electrical connections to this boiler must be made in accordance with all applicable local codes and the latest revision of the National Electrical Code, ANSI/NFPA-70. Installation should also conform with CSA C22.1 Canadian Electrical Code Part I if installed in Canada.

A properly rated shut-off switch should be located at the boiler. The boiler must be grounded in accordance with the authority having jurisdiction, or if none, the latest revision of the National Electrical Code, ANSI/NFPA-70.

Line voltage field wiring of any controls or other devices must conform to the temperature limitation of type TEW wire at **95°F, 35°C** above room temperature. Use copper conductors with a minimum size of #14 awg. Use appropriate wiring materials for units installed outdoors. The wire size must be compatible with the total amp draw of the circuit.

Refer to the wiring diagram supplied with the boiler for proper wiring connections and boiler full load amperage (FLA).

## GENERAL OPERATION

**WARNING**

Before proceeding read and fully understand the instructions contained in this manual. Do not attempt to operate this boiler if it has not been installed in accordance with the guidelines set forth in this manual. Failure to comply with this warning can result in extensive property damage, severe personal injury or death!

Should overheating occur or the gas supply fail to shut off, turn off the manual gas control valve to the appliance. **Do not interrupt water flow through the boiler.**

En cas de surchauffe ou si l'alimentation en gaz ne s'arrête pas, fermez manuellement le robinet d'arrêt de l'admission de gaz.

### Hydronic Heating Boilers (Fill System)

Open the make-up water valve and slowly fill the boiler and all of the radiation with water. Ensure that all bleed and drain valves are closed.

Adjust the make-up water pressure regulator so a minimum **5 psig, 82.7 kPa** system pressure is maintained at the highest point in the system piping. If a make-up water pump is used adjust it to maintain a minimum **12 psig, 82.7 kPa** pressure at boiler under operating conditions.

**NOTICE**

Glycol systems require a minimum of **20 psig, 137.8 kPa** at boiler operating conditions.

**Open the boiler piping bleed valves one at a time, to purge the air trapped in the primary and secondary heat exchanger. Refer to piping drawings (Figures 10 & 11) for bleed locations.**

With the boiler off, run the system pump for at least 30 minutes and bleed the system piping using the bleed valves. If strainers are used in the system piping, the make-up water valve should be closed and the strainers checked and cleaned.

The system expansion tank should be checked to ensure that the correct water level in the tank is maintained. The tank should be less than half full of water with the system full and adjusted to the correct operating pressure.

Start the boiler as described in the "OPERATING INSTRUCTIONS" section. Run the boiler for at least an hour. The system pump(s) and all radiation units must be operated during this time. Ensure that the make-up water valve is open.

Shut the boiler off and open the bleed valves to purge the air trapped in the heating system piping. Close the make-up water valve and check and clean the strainers and make-up water pressure reducing valve.

Open the make-up water valve and adjust the system pressure if necessary. The system should be checked and bled after three days of operation.

## OPERATING INSTRUCTIONS

### FOR YOUR SAFETY READ BEFORE OPERATING.

### POUR VOTRE SÉCURITÉ LISEZ AVANT DE METTRE EN MARCHÉ

- A. This appliance is equipped with an ignition device which automatically lights the pilot. Do not try to light the pilot by hand. Cet appareil est muni d'un dispositif d'allumage qui allume automatiquement la veilleuse. Ne tentez pas d'allumer la veilleuse manuellement.
- B. BEFORE OPERATING smell all around the appliance area for gas. Be sure to smell next to the floor because some gas is heavier than air and will settle on the floor.

**WARNING**

Propane gas may not always be detected by smell. Propane gas is heavier than air and can collect in low areas.

Propane gas can ignite or explode if an ignition source is present and result in death, serious injury and property damage!

### FOR YOUR SAFETY

- Have only qualified licensed professionals install, service and maintain this appliance and your gas system in accordance with all applicable codes.
- If you suspect a leak:
  1. Have everyone leave the building immediately.
  2. Do not attempt to light any appliance.
  3. Do not touch any electrical or electronic switches in the building.
  4. Do not use any phone in the building.
  5. Call your gas supplier from a phone outside of the building.
  6. If you cannot reach your gas supplier call the fire department.

AVANT DE FAIRE FONCTIONNER, renifllez tout autour de l'appareil pour déceler une odeur de gaz. Renifllez près du plancher, car certains gaz sont plus lourds que l'air et peuvent s'accumuler au niveau du sol.

### QUE FAIRE SI VOUS SENTEZ UNE ODEUR DE GAZ:

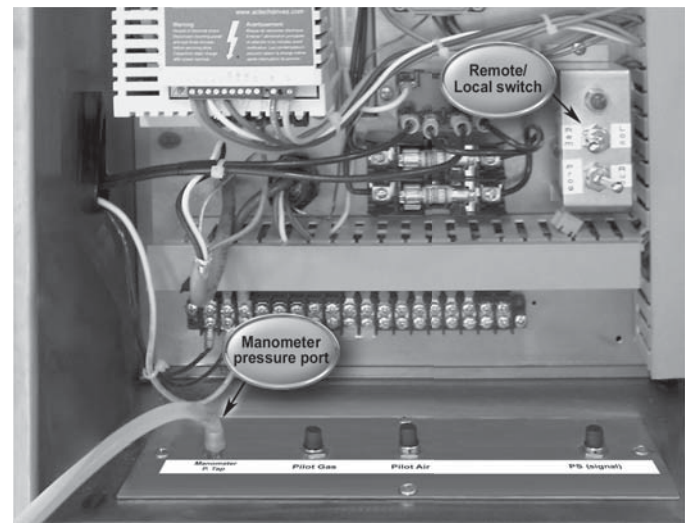
- Ne pas tenter d'allumer d'appareil.
  - Ne touchez à aucun interrupteur; ne pas vous servir des téléphones se trouvant dans le bâtiment.
  - Appelez immédiatement votre fournisseur de gaz depuis un voisin. Suivez les instructions du fournisseur.
  - Si vous ne pouvez rejoindre le fournisseur, appelez le service de incendies.
- C. Do not use this appliance if any part has been under water. Immediately call a qualified service technician to inspect the appliance and to replace any part of the control system and any gas control that has been under water.

N'utilisez pas cet appareil s'il a été plongé dans l'eau, même partiellement. Faites inspecter l'appareil par un technicien qualifié et remplacez toute partie du système de contrôle et toute commande qui ont été plongés dans l'eau.

## Operating instructions

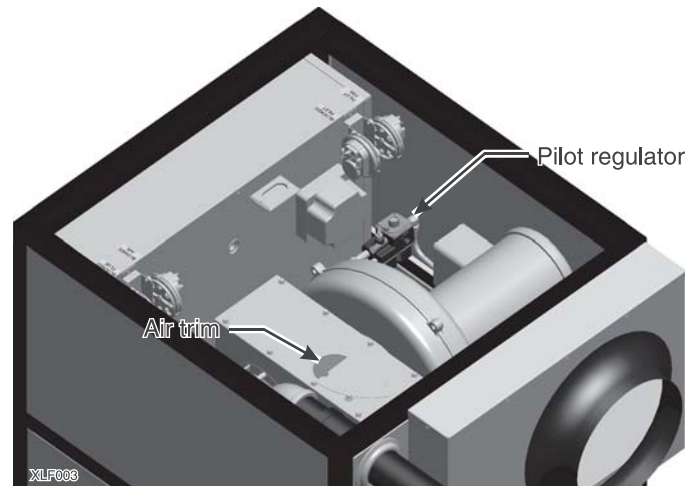
1. If, at any time, the boiler will not operate properly, follow the instructions "TO TURN OFF GAS TO APPLIANCE," page 25, and call your service technician or gas supplier.
2. Turn off all electrical power to the boiler.
3. Close main gas shut-off valve (field supplied), Figure 14.
4. Purge the gas piping up to the boiler's manual gas valve (located ahead of the main gas valve). When the bleeding is complete, check all gas joints up to the gas valve for leaks.
5. Wait five (5) minutes to clear out any gas.
6. Make sure all limits, pressures switches and safety device contacts are closed.
7. Open the main gas shut-off valve.
8. Disable any external call for heat, such as from a building management system or remote operating controller.
9. Toggle the remote/local switch (in control cabinet — see Figure 18) to **REMOTE**.
10. Turn on electrical power to the boiler.
11. Turn the power switch on the front of the boiler control cabinet to **ON**.
12. The HeatNet display will light up when the power is on. If all interlocks are properly closed, the display will say **STANDBY**. If not, refer to the XLF HeatNet Control manual for troubleshooting.
13. Slide the HeatNet control's low fire switch (on HeatNet control board) to the **LOW FIRE** position.
14. The boiler will begin the start-up sequence.
15. Allow the boiler to pre-purge and enter the pilot ignition cycle.
16. If pilot lights (indicated by a good flame signal 5.0 VDC) proceed to step 18. (See Honeywell R7800 literature for use of a meter to check flame signal if keypad readout is not available.)
17. If pilot is unstable (indicated by a low or erratic flame signal causing pilot flame failure), toggle the low fire switch to **DISABLE**, then back to **ENABLE** to start another cycle (reset the Honeywell control if necessary). Repeat for one or two more times to ensure the pilot line is purged of all air. If pilot is still unstable, the pilot gas pressure may need to be increased. See step 18.
18. Pilot pressure adjustment:
  - a. Switch the Honeywell control to **TEST** position within the first 10 seconds of the pilot ignition sequence.
  - b. Connect one side of a manometer or pressure gauge to the manometer pressure port (barbed) on the pressure test manifold (located inside control panel). See Figure 15. Leave the other side of the manometer open to the room.

**Figure 15** Manometer connections to the test manifold (in control cabinet)



- c. Measure pilot gas pressure by pressing and holding the service valve marked **PILOT GAS**.
- d. Set pilot gas pressure to 3.0 in WC ( $\pm 0.5$  in) by adjusting the pilot gas pressure regulator, inside the air box. Access from the boiler top cover. See Figure 16.

**Figure 16** Access to air trim adjustment and pilot regulator



- e. Check pilot air pressure using service valve marked **PILOT AIR**.
- f. Pilot air pressure should be 0.60 in WC ( $\pm 0.10$  in).

**WARNING** Combustion readings must be in the range specified in the following instructions. Adjust the boiler as necessary to ensure proper combustion.

### Verify low fire operation

1. Connect a manometer or Magnehelic gauge with the pressure side to the manifold pressure port. See Figure 15, for locations.
2. Set Honeywell R7800 control to RUN position. The boiler will operate at low fire because the low fire switch is in the low fire position.
3. Measure the flue gas CO<sub>2</sub> with the boiler running at low fire. Set low fire CO<sub>2</sub> to 8.0% – 8.5% by adjustment on the Dungs valve using a 3mm Allen wrench.
  - a. Turn the wrench in small increments (10 degrees at a time).
  - b. Allow time after each adjustment for the boiler to reach steady state.
4. After setting the CO<sub>2</sub>, measure the pressure signal, **Ps**.
  - a. Press the **Ps (signal)** button and read the pressure. The pressure at low fire should be as shown in Table 12.
  - b. If the pressure is outside of this range, follow the instructions in the HeatNet Control manual to set the required turndown.
  - c. Utilize the ACTech drive to trim the low fire pressure signal (Ps) as follows: Press the “Mode” button on the AC Tech Drive.
  - d. The drive will now require a password. Use the Arrow Keys on the AC Tech Drive to enter the password value of “523” then press “Mode”.
  - e. The parameters of the drive will be accessible at this point. Use the Arrow Keys on the AC Tech Drive to scroll to P45. Press “Mode” to view the entry; use the Arrow Keys to adjust the value to achieve the required combustion – CO<sub>2</sub>/O<sub>2</sub>, and pressure – (Ps) at low fire based on the desired turn down. The default values are listed in Table 12.
  - f. When complete press “Mode” again to save the value.

**WARNING** If using a U-tube manometer turned sideways for low pressure readings, you **MUST** turn the manometer upright before attempting to measure pressures at other than low fire. Pressure signal could reach up to 11 in when the boiler is at high fire, and can cause fluid to be pulled out of the manometer into the boiler. Should this occur, immediately shut down the boiler and contact the factory for procedure. Preferably, use a Magnehelic gauge instead of a U-tube manometer to measure the pressure to avoid this potential hazard.

**Table 12** Pressure signal (Ps), ACTech (P45) - (Nat Gas)

Firing rate	2500			3000		
	(PS) in WC	(P45)	(P46)	(PS) in WC	(P45)	(P46)
100%	-9.50	n/a	87.00	-11.00	n/a	77.00
20%	-0.40	11.00	n/a	-0.40	13.00	n/a
Firing rate	3500			4000		
	(PS) in WC	(P45)	(P46)	(PS) in WC	(P45)	(P46)
100%	-6.00	n/a	73.00	-8.50	n/a	75.00
20%	-0.40	10.50	n/a	-0.40	10.50	n/a

To determine signal in mm WC, multiply signal pressure by 25.4.

For LP Gas: All units are tested at factory. LP Combustion Values are located on Combustion Data label.

**WARNING** To ensure proper boiler operation, boilers that are vented sidewall and use room air must not be fired at less than 33% input.

5. Observe the burner flame after setting low fire. Make sure the flame is stable, but not too tight on the burner (causing infrared operation).

**WARNING** **DO NOT LEAVE THE BURNER IN AN INFRARED STATE.** A few random speckles of red are acceptable, but large concentrations of spots or large areas of red are not. If large amounts of red concentrations are observed, verify combustion readings.

**NOTICE** Leave the manometer connected to the test manifold. It will be needed for high fire operation testing.

### Verify high fire operation

1. Jumper the AA terminals on the HeatNet board and allow the boiler to rise to maximum (100%) input.
2. Allow the boiler to reach steady state combustion at high fire.
3. Verify high fire blower speed as follows:
  - a. With the manometer (or gauge) connected to the test manifold, press the **Ps (signal)** button and read the pressure.
  - b. The pressure at high fire should be as shown in Table 12.
  - c. If the pressure is NOT correct, follow step 4.



4. If the high fire signal pressure is not correct:
  - a. Follow the instructions in the HeatNet Control manual to calibrate the required input (Ps) for high altitude installations. The maximum firing rate value in the HeatNet control is factory set at (90%). At this setting, for sea level applications and with typical vent lengths, the boiler will be at rate. DO NOT increase above (90%) unless needed for high altitude installations.
  - b. For sea level installations only, the ACTech drive can be used to trim high fire input (Ps) as follows: Press the “Mode” button on the AC Tech Drive.
  - c. The drive will now require a password. Use the Arrow Keys on the AC Tech Drive to enter the password value of “523” then press “Mode”.
  - d. The parameters of the drive will be accessible at this point. Use the Arrow Keys on the AC Tech Drive to scroll to P46. Press “Mode” to view the entry; use the Arrow Keys to adjust the value to achieve the required combustion – CO<sub>2</sub>/O<sub>2</sub>, and pressure – (Ps). The default values are listed in Table 12.
  - e. When complete press “Mode” again to save the value.
5. If the pressure signal is correct, measure the flue gas CO<sub>2</sub>. It should be between 9% and 9.5%.
  - a. If CO<sub>2</sub> is correct, proceed to step 6.
  - b. If CO<sub>2</sub> is not within this range, adjust the air trim adjustment slightly (see Figure 16) on top of mixing box to achieve a CO<sub>2</sub> of 9% - 9.5%.
  - c. If adjusting the air trim adjustment does not correct the problem, contact technical support at the factory to troubleshoot the problem.
6. If CO<sub>2</sub> and pressure signal are correct, allow the boiler to reach steady state and verify supply gas pressure and check input rates as explained in the Gas Supply Piping section.
7. Remove jumper on AA and allow boiler to settle into minimum input. Observe the combustion readings to ensure the boiler is operating correctly.
8. When finished, disable the low fire hold switch and replace test ports to normal state. Remove the manometer connections and close the control panel door.
9. The Futera XLF boiler allows for many modes of operation and control methods. Reference the HeatNet Control manual.

## **TO TURN OFF GAS TO APPLIANCE**

1. Set the operating control to its lowest setting.
2. Turn off all electric power to the boiler if service is to be performed.
3. Close the manual main and pilot gas shut-off valves.

## **COMMENT COUPER L'ADMISSION DE GAZ DE L'APAREIL**

1. Réglez le thermostat à la température la plus basse.
2. Coupez l'alimentation électrique de l'appareil s'il faut procéder à l'entretien.
3. Fermer la vanne manuelle d'arrêt d'alimentation de gaz.

## **SEQUENCE OF OPERATION**

### **NO DEMAND**

#### **Standby**

1. The boiler is idle with no interlocks in the fault condition.

### **DEMAND**

#### **Pre-Purge**

1. The blower operates at purge RPM. The water flow interlock must 'make' within 15 seconds after the demand signal is initiated.
2. The Honeywell 7800 starts a 10 second purge delay once the air prove switch contacts close.

#### **Pilot Run - % Input**

1. The blower operates at minimum ignition setting. See the calibration section in the HeatNet Control manual to enter the calibration menus.
2. The ignition transformer is energized. The pilot solenoid valve opens for the 10 second pilot ignition trial.

#### **Main Run % Input**

1. The main gas valve opens.
2. The ignition transformer is de-energized.
3. The pilot solenoid valve closes.
4. The blower stays at the minimum input setting for 3 seconds then operates at demand % input. See the calibration section in the HeatNet Control manual to enter the calibration menus.

### **NO DEMAND**

#### **Post-Purge**

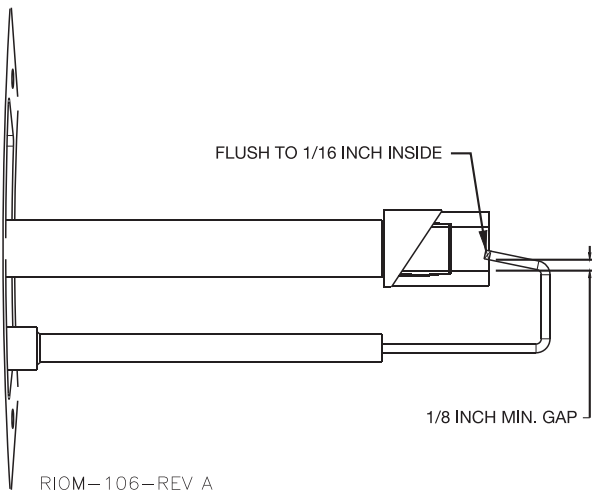
1. The main gas valve closes.
2. The blower operates at purge RPM for 10 seconds.
3. The boiler is idle with no interlocks in the fault condition.

## CHECKING & ADJUSTMENTS

### Spark Gap

With the main and pilot gas manual valves in the closed position energize the unit. Observe the trial for ignition to confirm that the spark is strong and continuous. If not check and adjust the spark gap as shown in Figure 17.

**Figure 17** Spark Gap



### Pilot Adjustment

- The pilot pressure has been factory set at **3 in WC**, and shouldn't need adjustment.
  - With the boiler powered, generate a call for heat.
  - When the prepurge is complete the ignition/pilot trial will begin.
- To adjust the pilot the following steps must be taken:
  - Put the Honeywell RM7800 test switch in the test position. The control will hold in the ignition/pilot sequence, allowing you to check the pressure.
  - Connect one side of a manometer or pressure gauge to the manometer pressure port (barbed) on the pressure test manifold (located inside control panel). See Figure 13. Leave the other side of the manometer open to the room.
  - Measure pilot gas pressure by pressing and holding the service valve marked **PILOT GAS**.
  - Set pilot gas pressure to **3.0 in WC (± 0.5 in)** by adjusting the pilot gas pressure regulator, inside the air box. Access from the boiler top cover. See Figure 16.
  - Check pilot air pressure using service valve marked **PILOT AIR**.
  - Pilot air pressure should be **0.60 in WC (± 0.10 in)**.

**CAUTION** Never force the regulator adjustment screw beyond the stop limits or damage to the regulator will occur!

### Required Gas Pressure

Provide gas supply pressure at inlet to boiler gas train as follows:

**Table 13**

	Gas supply pressure (Nat/LP)	
	Inches water column	mm water column
Minimum	<b>3.5</b>	88.9
Maximum	<b>14</b>	356

- Measure pressure when the boiler is firing at full rate. Low gas pressure could indicate undersized gas line or insufficient gas supply.
- Static and operating gas pressure required at the gas valve inlet is listed in the Table 13.

**WARNING** If the gas pressure is above the limit in Table 13, a lock-up style gas pressure regulator suitable for dead-end service, (such as an Equimeter or Fisher) must be installed to prevent increase (creep) of gas pressure when the units are not operating and gas supply pressure, as indicated in Table 13, must be maintained to the inlet of the boiler gas train not to exceed a maximum of (1.0 in WC) drop when firing from minimum input to full load of the gas supply line and all the appliances running.

This pressure regulator (supplied by others) may be installed at the service entrance to each unit or a "master" regulator sized to handle multiple units with adequate turndown capability may be utilized. Consult local gas utility or regulator manufacturer for recommendations to meet specific job site requirements.

### Input Rate — Natural Gas

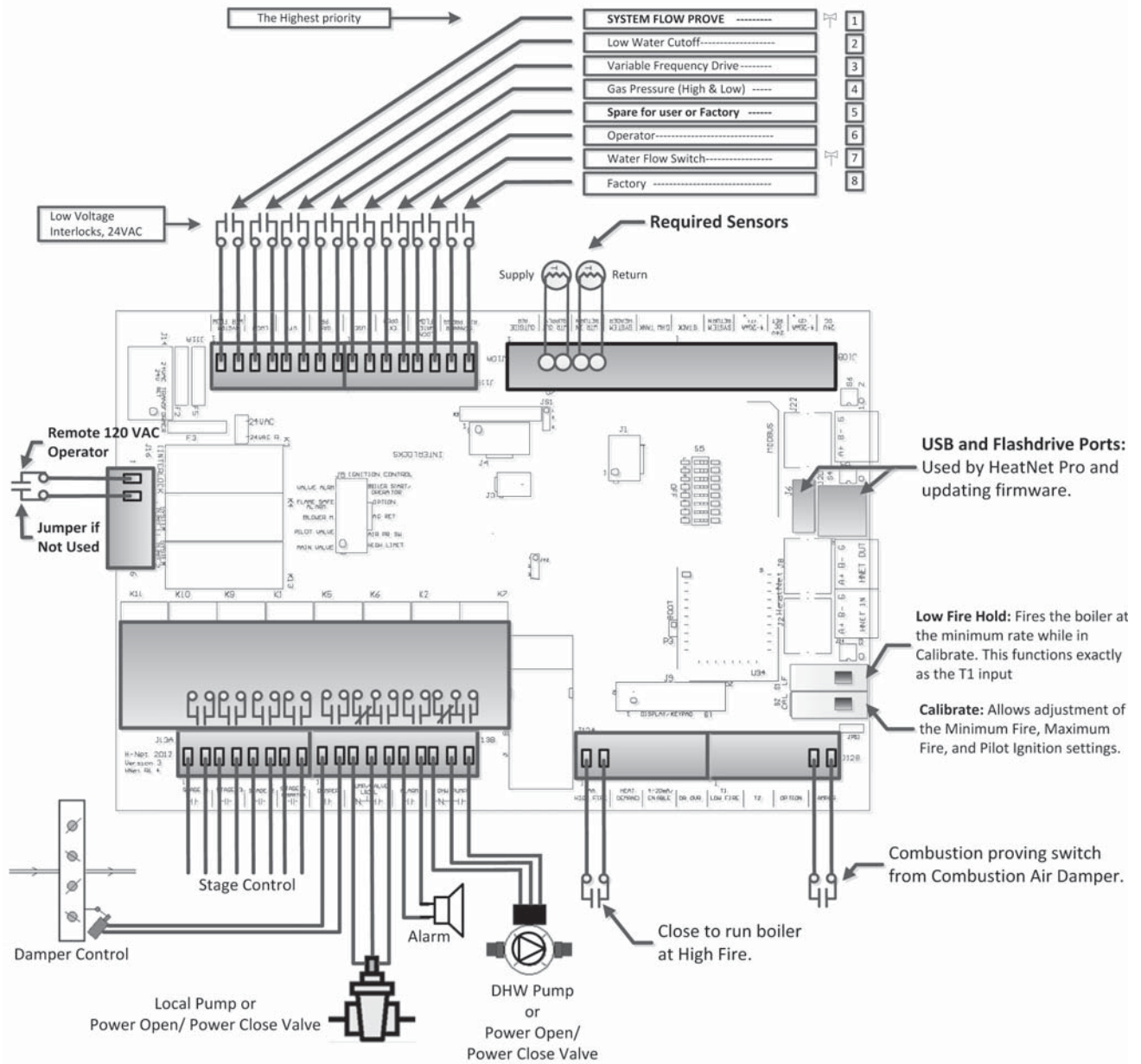
Gas appliances are rated based on sea level operation with no adjustment required at elevations up to **2000 ft, 610 m**. At elevations above **2000 ft, 610 m** input ratings should be reduced by 4% for each **1000 ft, 305 m**.

#### Check the input rate as follows:

- Turn off all other gas appliances that use the same gas meter as the boiler.
- Call your gas supplier and ask for the heating value of the gas.
- Start the boiler and let it run for 15 minutes.
- Using the gas meter and a stopwatch, clock the time that it takes to burn **10 ft<sup>3</sup>, 0.28 m<sup>3</sup>** of gas and divide this time by 10.
- Insert the heating value and the time, in seconds, into the formula below.
- Input = (heating value, Btu/hr)/(3600)/(time, seconds)
- If the computed rate deviates by more than 5% from the rated input value of the unit, consult factory.

**CAUTION** Never increase the input to the boiler above that for which it is rated. Doing so can cause premature failure of the boiler!

**Figure 18** RBI Field Wiring to HeatNet Board (Board Revision 3.0 and Greater)



## CONTROL DESCRIPTION

### Low Water Cutoff

If the boiler is to be installed above radiation or if required by other codes or regulations, install a low water cutoff in appropriate piping. Wire the switch to the “Interlock” contacts as illustrated on “Field Wiring” schematic. Ensure that the low water cutoff device(s) will function properly.

### Operating Control

The preferred control setting for potable hot water is **130°F, 54°C**. The operating control should be set to the lowest setting that will satisfy the consumer’s needs.

**WARNING** Setting the thermostat or operation control too high can result in scalding resulting in severe personal injury!

### High Limit (Aquastat)

The high limit is located in the top control area of the boiler. A remote capillary bulb is run to a well on the outlet side of the supply header. The high limit can be reset by depressing the red button.

The unit heater high limit should be set a minimum of **20°F, 11°C** higher than the operating control. Refer to the HOT WATER SUPPLY section for the proper supply water temperature.

### Flow Switch

A flow switch is provided in the water outlet piping to prevent the boiler from firing without adequate water flow through the heat exchanger.

## DIAGNOSTICS

The Futera Fusion XLF has a display that indicates the sequence of operation. The display will also list faults should the unit fail to operate. An explanation of each status message and fault can be located in HeatNet Control Manual under status screen fault display section.

### Status Screen Fault Display

There are numerous interlock switches and software limits that are detected. Each of these, when tripped will produce a display message, an audible beeping, and an alarm relay closure. The fault is displayed first, then after a second, the time the fault occurred is displayed. This cycle will keep occurring until the fault is cleared.

These faults are:

**HIGH LIMIT:** When the high limit aquastat trips the following message is displayed:

FAULT HIGH LIMIT	SYSTEM SET  160°F
---------------------	-------------------------

FAULT 10/27 9:16	SYSTEM SET  160°F
---------------------	-------------------------

The high limit interlock breaks power to the ignition control (shutting it off) and effectively removes any chance of the gas valve receiving power. The Futera Fusion XLF series control will remain powered to display the fault, latch the alarm relay/audible beeper, and to access the log. The interlock is located on J5, HIGH LIMIT.

**INTERLOCK SPARE 3:** This is a reserved interlock input that is normally jumpered at the factory, but can have a remote interlock connected as a field install. The interlock is located on J11A, SPARE 3.

FAULT INTERLOCK SPARE 3	SYSTEM SET  160°F
----------------------------	-------------------------

**LOW WATER CUTOFF:** If there is a low water condition reported by the low water cutoff switch this fault is displayed. Check that there is water flow and water in the boiler. There is a reset switch located on the LWCO box. The interlock connection is located on J11A, LWCO.

FAULT LOW WATER CUTOFF	SYSTEM SET  160°F
---------------------------	-------------------------

**VAR FREQ DRIVE:** The variable frequency drive, which controls the blower, reports this fault in the event of over current or other conditions that would cause it to shut down. If this is the case, check the fault indicators on the VFD. The interlock is located on J11A, VFD.

FAULT VAR FREQ DRIVE	SYSTEM SET 160°F
-------------------------	---------------------

**GAS PRESSURE:** The optional gas pressure switches (high pressure and low pressure) are connected in series, so if either trip, a fault will be reported here. A reset switch is located on the gas pressure switches. The interlock is located on J11A, GAS PR.

FAULT GAS PRESSURE	SYSTEM SET 160°F
-----------------------	---------------------

**INTERLOCK SPARE 4:** This is also a spare interlock (similar to INTERLOCK SPARE 3) for future expansion or use as a field interlock. The interlock is located on J11B, SPARE 4.

FAULT INTERLOCK SPARE 4	SYSTEM SET 160°F
----------------------------	---------------------

**FLOW SWITCH ERROR:** Once the Futera Fusion series boiler receives a call for heat, it closes the circulator pump relay. It then waits 10 seconds to prove flow. If there is no flow, the flow switch alarm will be set. Every 10 seconds the circulator pump relay will cycle ON for 10 seconds and then OFF for 10 seconds to try and establish flow. The interlock connection is located on J11B, WTR FLW.

FAULT WATER FLOW SWITCH	SYSTEM SET 160°F
----------------------------	---------------------

**IGNITION CTRL ALARM:** The ignition control alarm is displayed if the ignition control detects a fault. This could be a flame failure, air proving switch, or other fault associated with the ignition control. When this fault occurs, you will need to refer to the ignition control for the reason.

FAULT IGNITION CTRL ALARM	SYSTEM SET 160°F
------------------------------	---------------------

**IRI ALARM:** The optional IRI alarm is the alarm from the gas valve. If this alarm is set check the gas valve.

FAULT IRI ALARM	SYSTEM SET 160°F
--------------------	---------------------



## MAINTENANCE

**WARNING** Disconnect electrical power and close the manual gas shut off valve before performing maintenance or severe personal injury may result!

**CAUTION** Servicing, inspection and adjustment must be done by a trained technician in accordance with all applicable local and national codes. Improper servicing or adjustment can damage the boiler!

The boiler must be cleaned and inspected at least once a year and before each heating season. Make sure that the burner and ignition components are free from dust, soot, dirt, corrosion or other deposits that would impair the boiler's performance. Refer to Figure 15 for component identification.

**CAUTION** Improper burner servicing can result in premature burner failure voiding the warranty!

### Pilot and burner removal

1. Close the manual shutoff valves in the gas supply line and turn off electrical power to the boiler.
2. Remove the jacket top panel.
3. Remove wires from the spark rods and remove the UV sensor from the transition piece.
4. Remove the pilot assembly:
  - a. Disconnect the compression nut at the front of the pilot block.
  - b. Remove the pilot gas tubing.
  - c. Remove the (2) screws from the pilot block.
  - d. Remove the pilot assembly.
5. Disconnect the flexible gas line from the manifold.
6. Disconnect the wires to the fan and remove the (2) bolts and the fan hold-down plates that secure the fan to the transition piece.
7. Lift and remove the fan housing from the boiler, taking care not to damage the spark rods and or their alignment.
8. Remove the four nuts holding the transition piece to the heat exchanger.
9. Remove the transition piece, taking care not to damage the O-ring.
10. Remove the burner, taking care not to damage the gasket.
11. Replace all components after servicing.

### Heat exchanger inspection

1. Close the manual shutoff valves in the gas supply lines and turn off electrical power to the boiler.
2. Remove burner following the instructions in the Burner Removal section.
3. Remove the front jacket panel and combustion chamber door.
4. Inspect the inside and outside of the heat exchanger for signs of damage, sooting or corrosion.

5. The outside surfaces of the copper tubes should be free of any soot deposits. A slight black smudge is normal with some types of gases. Black soot indicates poor combustion. Green deposits indicate condensation due to low return water temperatures. In either case the heat exchanger must be cleaned thoroughly and the problem resolved before the boiler is returned to service.
6. If there are no signs of damage, sooting or corrosion, reassemble the unit following the previous steps in reverse order.
7. A badly corroded or damaged heat exchanger must be replaced, see the Heat Exchanger Repair & Replacement section.

### Heat exchanger cleaning

1. Close the shut off valves in the inlet and outlet piping. On heating systems close the system fill valve and relieve the system pressure from the boiler by carefully lifting the relief valve or opening the drain valve.
2. Disconnect the boiler from the system piping.
3. Remove the eight bolts on the rear pipe enclosure panel.
4. Remove the front jacket panel and combustion chamber door.
5. Slide the heat exchanger out of the unit.
6. Remove the "V" baffle straps and "V" baffles.
7. Thoroughly clean the heat exchanger with water from a high-pressure hose. Use a soft bristle brush if necessary.
8. Replace the cleaned heat exchanger and other components in the reverse order of their removal.

### Heat exchanger repair & replacement

1. A leaking or otherwise damaged tube(s) can be replaced as outlined in steps 2 through 8.
2. Remove the heat exchanger from the boiler as outlined in the Heat Exchanger Cleaning section.
3. Remove the pipe plugs from the inlet/outlet and return headers opposite from the ends of the tube(s) being replaced.
4. Carefully cut the damaged tube(s) in half, taking care not to damage the adjacent tubes and remove.
5. Install and swage/expand in place the new tube(s). Replace the pipe plugs using a suitable thread sealant on each one.
6. Sagging or distorted heat exchanger tubes are an indication of low water flow through the system. A damaged heat exchanger must be replaced and the condition that caused the damage resolved before the boiler is returned to service.
7. Replace the heat exchanger and other components in the reverse order of their removal.

### Air intake & vent system

Thoroughly inspect the air intake and vent systems for any signs of blockage, corrosion or leakage. Immediately replace any unsound vent system piping. Inspect the air filter and wash with warm water and soap if dirty.

### Controls

Use the “GENERAL OPERATION” and “CHECKING AND ADJUSTMENTS” sections of this manual for reference.

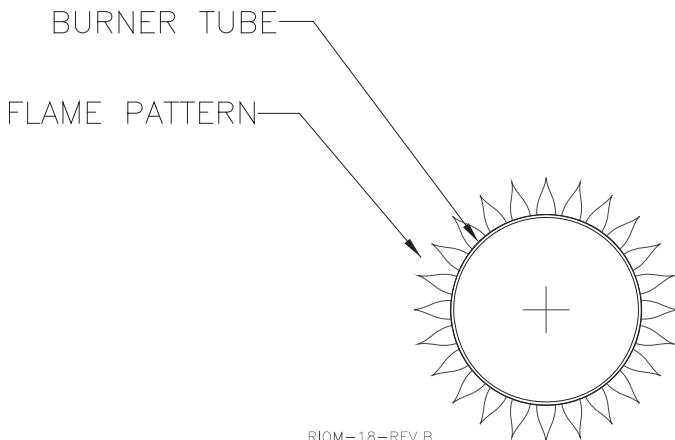
1. Check the operating controls for proper operation.
2. A float type low water cutoff device must be flushed out per the manufacturers’ instructions.
  - a. The probe on a probe low water cut off must be removed, cleaned and inspected at least once a year.
  - b. Ensure that the low water cutoffs operate properly. If not, replace them.
3. The flow switch contacts must be open when water flow is not present.
4. The relief valve should not weep or discharge water at normal system pressure. If it does, contact a qualified service technician to have it inspected.

**WARNING** NEVER try to clean or repair the relief valve! If the valve fails to operate properly, have it replaced!

5. The aquastat high limit controls the maximum water temperature in the boiler.
  - a. If the water temperature reaches the set temperature before the demand for heat has been met, the aquastat high limit should shut the boiler off.
  - b. The water temperature should never exceed the maximum set point of **250°F, 121°C**, for boilers and **210°F, 99°C** for water heaters.
  - c. The aquastat high limit cannot be repaired. If it fails to function properly, replace it.
6. Visually check the pilot and main burner flames to ensure proper operation, see Figure 19.

**WARNING** A yellow, floating flame indicates a lack of combustion air. Do not operate the boiler until the problem is solved or severe personal injury or death may occur!

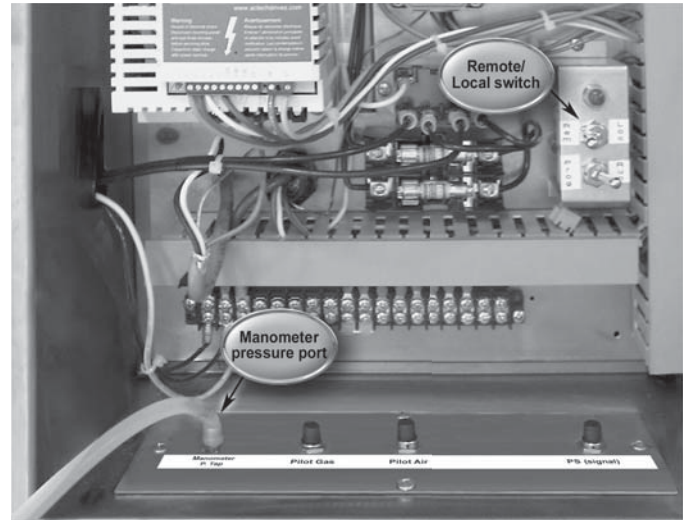
**Figure 19** Main Burner Flame



### Manometer test port manifold

1. The Futera Fusion XLF includes a manometer test manifold. Connect the manometer pressure hose to the Pressure Tap port shown in Figure 20. These pressures signals may be used for troubleshooting when specified by factory support.
2. Figure 21, shows the sensor hose connections inside the Futera Fusion XLF air box.

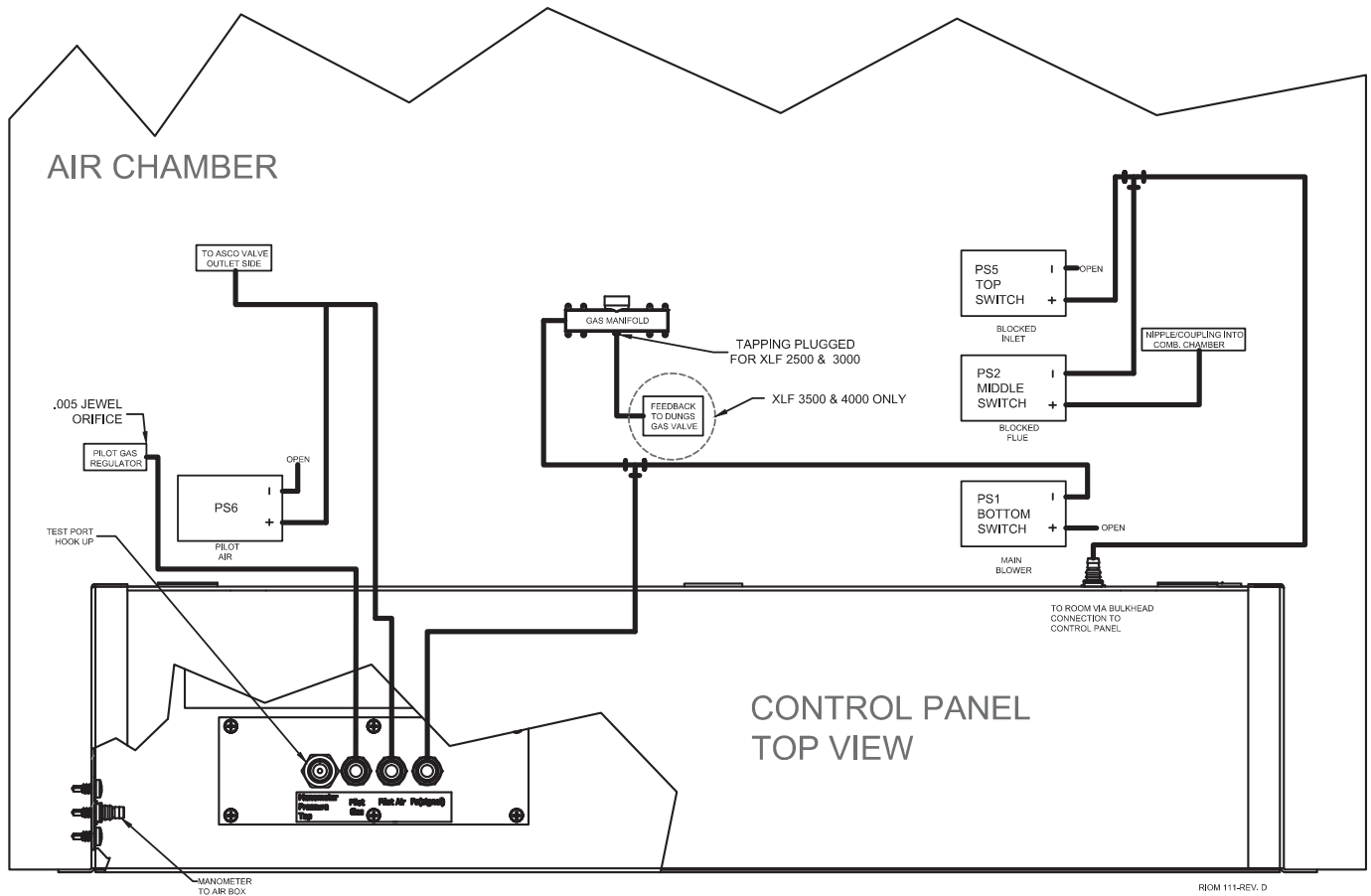
**Figure 20** Manometer connections to manifold





**Figure 21** Futera Fusion XLF pressure sensor hose routing

Switch	For	Switch Settings in WC			
		2500	3000	3500	4000
PS1	Main Blower	(-) 0.20	(-) 0.20	(-) 0.20	(-) 0.20
PS2	Blocked Flue	(+) 3.00	(+) 3.00	(+) 4.00	(+) 4.00
PS5	Blocked Inlet	(-) 2.00	(-) 2.00	(-) 2.00	(-) 2.00
PS6	Pilot Air	(+) 0.36	(+) 0.36	(+) 0.36	(+) 0.36



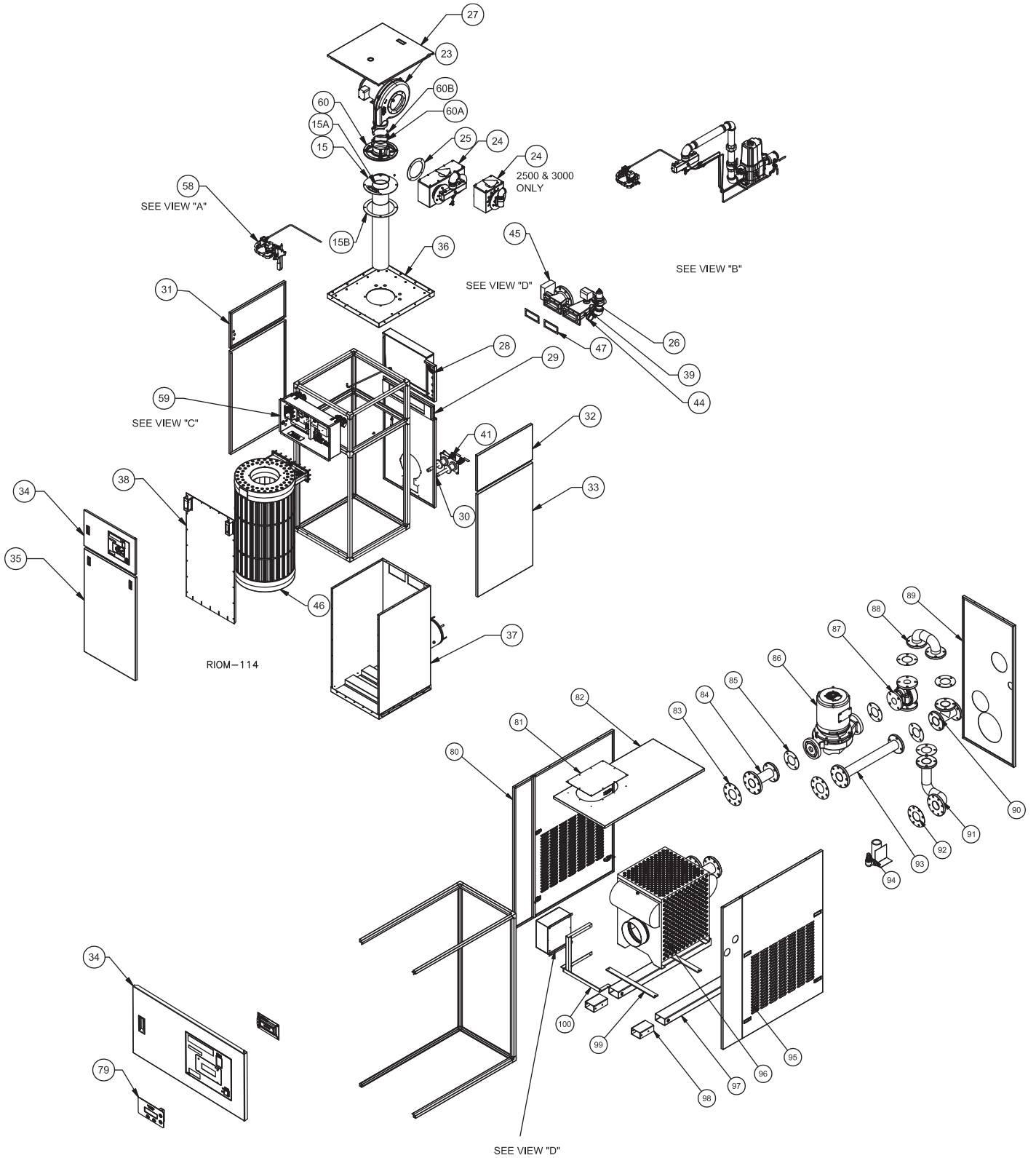
RIOM 111-REV. D

Troubleshooting A Startup

	Symptom	Identify Source	Check	Action
1.	An Interlock is tripped.	<p>1. Is it a 24 VAC Interlock?</p> <p>2. Is it a 120 VAC Interlock/ Alarm?</p> <p>3. Internal Alarms</p>	<p>1. All 24 VAC Interlocks are located on J11A and J11B. Examples of 24 VAC Interlocks:</p> <ol style="list-style-type: none"> <li>1.SPARE3</li> <li>2. Variable Frequency Drive(VFD)</li> <li>3. Low Water Cutoff(LWCO),</li> <li>4. Gas Pressure</li> <li>5. Spare 4</li> <li>6. Operator OPLIM</li> <li>7. Water Flow</li> <li>8. Air Pressure from UV Sensor.</li> </ol> <p>2. All 120 VAC interlocks/Alarms are located on J5. These include:</p> <ol style="list-style-type: none"> <li>1.FLAME SAFE ALARM (Ignition CTRL ALARM)</li> <li>2. Valve Alarm (IRI ALARM)</li> <li>3. XS_FACTORY (Reserved)</li> <li>4. HIGH LIMIT</li> </ol> <p>1. OPEN SENSOR</p> <p>2. SHORTED SENSOR</p> <p>3. COMBUSTION AIR DAMPER</p>	<p>1. Use a multimeter and check for 24 VAC on J11A, J11B to identify which interlock has tripped. Reset the Interlock or check for disconnected wiring or shorts.</p> <p>The Air Pressure from UV Sensor interlock if displayed will allow the boiler to function, but it needs to be functional while the boiler is running for it to clear.</p> <p>1. Use a multimeter on J5 to check for 120 VAC on these interlocks (except the HIGH LIMIT). The High Limit Interlock is displayed when there is no 120 VAC, since the HIGH LIMIT breaks the 120VAC to the Ignition Control.</p> <p>NOTE: Stray Voltages Greater than 8 VAC and less than 18 VAC on these interlocks can cause intermittent operation. If this is the case, check for back fed voltages from field wiring.</p> <p>Check sensor voltages at J10A and J10B. The Temperature sensor inputs should be between 0 VDC and 5 VDC measured across the sensor. Example: At 77°F, the voltage would read 2.5 VDC.</p> <p>The combustion air damper prove switch must be wired across SPARE 1 and must be a "DRY" contact. Do not apply a voltage to this input, the input supplies it's own voltage/current.</p>
2.	Proceed to HeatNet Control Manual for more details and problem resolution.			

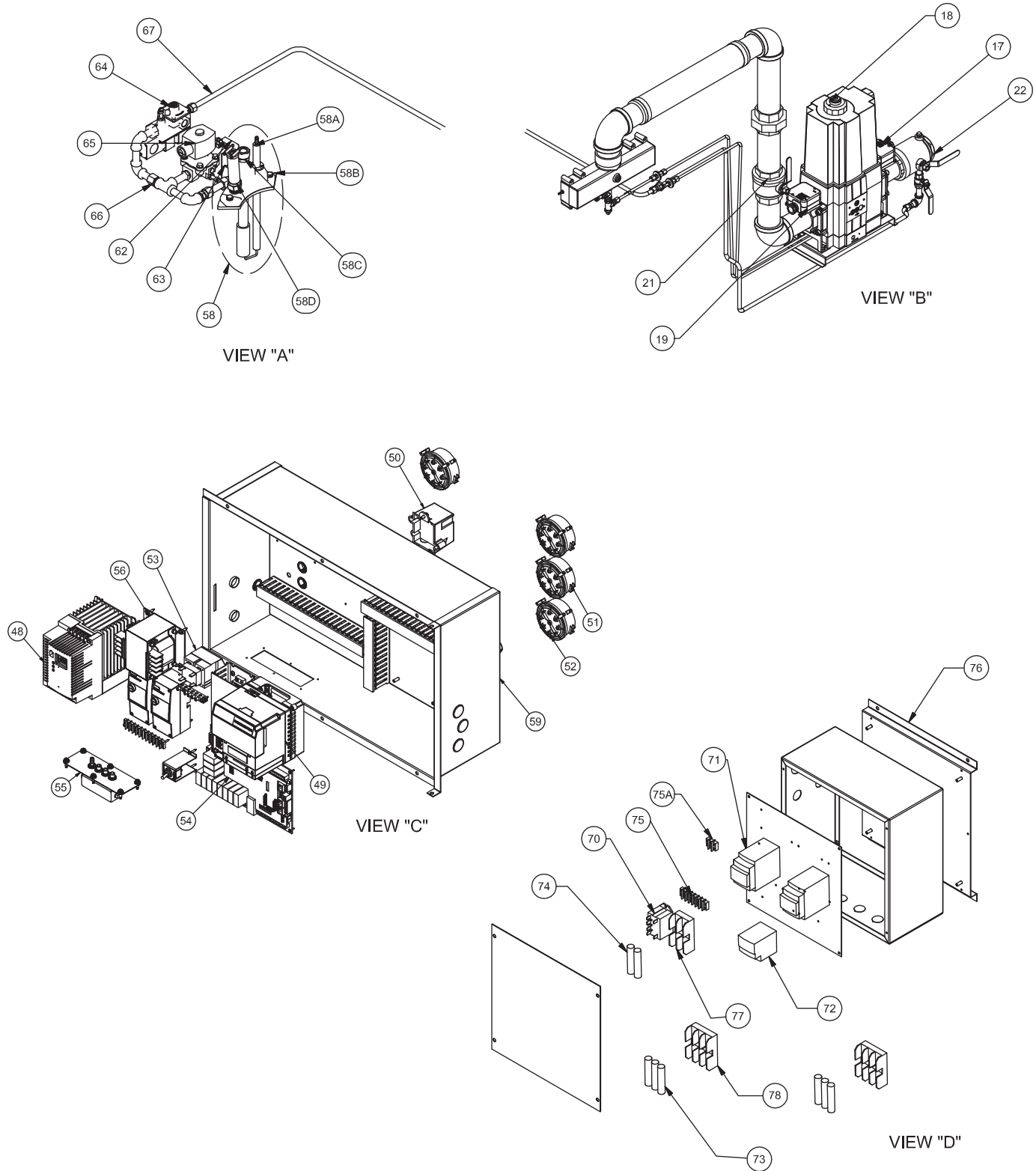
### REPAIR PARTS

Figure 22 Repair Parts



### REPAIR PARTS (CONTINUED)

Figure 22 Repair Parts (CONTINUED)



**REPAIR PARTS** (CONTINUED)

Ref #	Name of Part	Part #	Model Size with Item Quantities Below			
			2500	3000	3500	4000
13	Left Base Channel	04-1018	1	1	1	1
	Right Base Channel	04-1022	1	1	1	1
15	Burner	10-0322	1			
		10-0293		1		
		10-0323			1	
		10-0294				1
15a	Burner O'ring	(must order as kit 21-2009)				
15b	Burner Gasket	(must order as kit 21-2009)				
17	High Gas Pressure Switch (Manual Reset)	11-0421	1	1	1	1
18	Gas Valve, MBC	11-0227	1	1		
	Gas Valve, MBC	11-0218			1	1
NS	Flange 1-1/2"	11-0214	2	2		
	Flange 2"	11-0219			2	2
19	Low Gas Pressure Switch (Manual Reset)	11-0422	1	1	1	1
21	Firing Valve, 1-1/2"	11-0458	1	1		
	Firing Valve, 2"	11-0459			1	1
22	"A" Valve, 1-1/2"	11-0467	1	1		
	"A" Valve, 2"	11-0454			1	1
23	Blower	12-0019	1	1		
		12-0023			1	1
24	Mixing Box Assy	70-3555	1	1		
		70-3554			1	1
25	Mixing Box Gasket	(must order as kit 21-2009)				
NS	Gas Injectors, NG	10-1005	1			
		10-1007		1		
		10-1002			2	2
		10-1006	1			
		10-1008		1		
NS	Gas Injectors, LP	10-1004			2	2
		10-1004			2	2
26	Flow Switch	14-0205	1	1	1	1
27	Jacket Top Panel	70-2413.1	1	1	1	1
28	Air Filter	09-0485	1	1	1	1
29	Rear Pipe Enclosure Assy	70-3510	1	1	1	1
30	Jacket Lower Rear Panel	03-3786	1			
		03-3787		1		
		03-3788			1	
		03-3789				1
31	Jacket Upper Left Panel	70-2474	1	1	1	1
32	Jacket Upper Right Panel	70-2471	1	1	1	1
33	Jacket Lower Left/Right Side Panel	03-2838	2			
		03-2839		2		
		03-2840			2	
		03-2841				2
34	Jacket Upper Front Panel	70-3617.1	1	1	1	1
NS	Handle	20-0063	1	1	1	1
35	Lower Front Jacket Panel	70-3535	1			
		70-3536		1		
		70-3537			1	
		70-3538				1
36	Combustion Chamber Top Panel	70-3561	1	1	1	1
	Manning Glass Insulation (per square foot)	05-0104	9	9	9	9
37	Combustion Chamber Side/Rear Assy	70-3566	1			
		70-3567		1		
		70-3568			1	
		70-3569				1

**REPAIR PARTS** (CONTINUED)

Ref #	Name of Part	Part #	Model Size with Item Quantities Below			
			2500	3000	3500	4000
38	Combustion Chamber Door Assy	70-3572	1			
		70-3573		1		
		70-3574			1	
		70-3575				1
39	Pressure Relief Valve 50#	30-0384	1	1	1	1
	Pressure Relief Valve 125#	13-0053	1	1	1	1
NS	Latch	20-0045	2	2	2	2
NS	Ball Valve	11-0395	1	1	1	1
41	Drain Assy	70-2561.1	1	1		
		70-2562.1			1	1
44	Tridicator 30 - 60 psi	13-0308	1	1	1	1
	Tridicator 75 - 160 psi	13-0305	1	1	1	1
45	LWCO #550LSV	14-0256	1	1	1	1
46	Heat Exchanger Assembly (Copper) Cast Iron	70-3584R	1			
		70-3585R		1		
		70-3586R			1	
		70-3587R				1
	Heat Exchanger Assembly (Copper) Bronze	70-3576R	1			
		70-3577R		1		
		70-3578R			1	
		70-3579R				1
	Heat Exchanger Assembly (Cupronickel) Cast Iron	70-3588R	1			
		70-3589R		1		1
		70-3590R			1	
		70-3591R				1
Heat Exchanger Assembly (Cupronickel) Bronze	70-3580R	1				
	70-3581R		1			
	70-3582R			1		
	70-3583R				1	
NS	Heat Exchanger "V" Baffles	03-3997	1			
		03-3998		1		
		03-3999			1	
		03-4000				1
	Heat Exchanger "V" Baffle Strap	03-3946	2	2	2	2
47	Flange Gasket	06-0062	2	2	2	2
48	Frequency Drive	15-0230	1	1		
		15-0234			1	1
49	Flame Safeguard, RM7895C	16-0024R	1	1	1	1
50	Spark Generator	16-0008	1	1	1	1
51	Air Pressure Switch	11-0419	1	1	1	1
52	Fan Prove Switch	11-0420	1	1	1	1
		11-0419	1	1	1	1
53	Transformer, 50 VA	15-0007	1	1	1	1
NS	High Limit, Jumo, (CB)	14-0013	1	1	1	1
NS	High Limit, Jumo, (CW)	14-0014	1	1	1	1
NS	High Limit, Jumo, (CB) Auto Reset	14-0114		1	1	1
NS	High Limit, Jumo, (CW) Auto Reset	14-0115		1	1	1
NS	Thermometer Well, 3/8 x 2	13-0102	2	2	2	2
NS	High Limit Well, 3/8 x 3	13-0104	2	2	2	2
54	Main Board (HeatNet)	16-0047	1	1	1	1
NS	Display Board	40-0088	1	1	1	1
NS	Ignition Cable	44-0063	1	1	1	1
NS	Ribbon Cable	40-0115	1	1	1	1
55	Service Valve Assembly	70-3666	1	1	1	1

**REPAIR PARTS** (CONTINUED)

Ref #	Name of Part	Part #	Model Size with Item Quantities Below			
			2500	3000	3500	4000
56	250v Transformer	15-0015			1	1
NS	Power Switch	48-0013	1	1	1	1
NS	Toggle Switch Remote/Local	48-0014	1	1	1	1
NS	10K Temperature Sensor	14-0325	3	3	3	3
NS	Purge Timer, ST7800	16-0007	1	1	1	1
NS	Keyboard Display Module, S7800A	16-0010	1	1	1	1
58	Pilot/Flame Rod Kit	70-3615	1	1	1	1
58a	Electrode	16-0335	2	2	2	2
58b	O'ring	06-0008	1	1	1	1
58c	View Port Assembly	70-2205	1	1	1	1
58d	Mini Peeper, C7027A (not included in 70-3615)	16-0009	1	1	1	1
NS	Turbo Pilot Torch	70-2559	1	1	1	1
NS	UV Amplifier, R7849B	16-0037	1	1	1	1
59	Control Box Assembly	70-3609	1	1	1	1
60	Fan Transition Collar	01-0201S	1	1	1	1
60a	Blower O'Ring	06-0004	1	1	1	1
60b	Fan Holddown Plate	04-0596	1	1	1	1
62	Mini Fan	12-0021	1	1	1	1
64	Solenoid Valve w/Regulator, NG	11-0372	1	1	1	1
	Solenoid Valve w/Regulator, LP	11-0374	1	1	1	1
65	Air Shut Off Valve	11-0376	1	1	1	1
66	Pilot Orifice, .052 NG	10-0140	1	1	1	1
	Pilot Orifice, .040 LP	10-0139	1	1	1	1
67	Pilot Tube 3/8	62-0102	2	2	2	2
70	Power Relay	15-0118	1	1	1	1
71	VFD Contactor	15-0211	1	1	1	1
72	Relay Overload (5.5 - 8 Amp)	15-0214	1	1	1	1
	Relay Overload (9 - 13 Amp)	15-0215	1	1	1	1
	Relay Overload (2.5 - 4 Amp)	15-0216	1	1	1	1
	Relay Overload (4 - 6 Amp)	15-0217	1	1	1	1
	Relay Overload (12 - 18 Amp)	15-0219	1	1	1	1
73	Fuse, 3HP, 230V (pump)	48-0627			3	
	Fuse, 5HP, 480V (pump)	48-0637	2	2		3
	Fuse, 15A, 600V (VFD)	48-0621			3	3
74	Fuse, 25Amp, 600V (VFD)	48-0622	2	2		
	Fuse (transformer)	48-0376			2	2
75	Terminal Strip, 8P	48-0154	1	1	1	1
75a	Terminal Strip, 3P	48-0167	1	1	1	1
76	Power Supply Box	70-3750	1	1	1	1
77	Fuse Block, 2P (VFD)	48-0641	1	1		
	Fuse Blcok, 2P (pump/transformer)	48-0643	1	1	1	1
78	Fuse Block, 3P (pump)	48-0462			2	2
79	Keypad Overlay	82-0189	1	1	1	1
NS	Rating Plate	82-0054	1	1	1	1
NS	Futera XLF Overlay	82-0192	1	1	1	1
NS	Silicone Tubing	06-0051	per foot			
NS	Silicone	66-0151	1	1	1	1
NS	Vent Termination Hood 8"	09-0113	1	1		
	Vent Termination Hood 10"	09-0115			1	1
NS	Air Intake Hood 8"	09-0103	1	1		
	Air Intake Hood 10"	09-0104			1	1

**REPAIR PARTS** (CONTINUED)

Ref #	Name of Part	Part #	Model Size with Item Quantities Below			
			2500	3000	3500	4000
80	Jacket Rear Front/Left Extension	70-3777.1	1			
		70-3777.2		1		
		70-3777.3			1	
		70-3777.4				1
	Jacket Rear Front/Right Extension	70-3776.1	1			
		70-3776.2		1		
		70-3776.3			1	
		70-3776.4				1
81	Jacket Top Plate	03-3186.1	1	1		
		03-3186.3			1	1
82	Jacket Rear Top Panel	70-3786	1	1		
		70-3787			1	1
83	9" x 4-1/2" Gasket (8 hole)	06-0144	2	2	2	2
84	Pipe Inlet Adapter	70-3716	1			
		70-3717		1		
		70-3754			1	1
85	7-1/2" x 3-1/2" Gasket (4 hole)	06-0143	6	6	6	6
86	Pump With Impeller	12-0666	1	1		
		12-0667			1	
		12-0665				1
87	3-Way Valve	13-0210	1	1	1	1
88	Pipe U-Elbow Assy	70-3752	1	1	1	1
89	Pipe Rear Back Extension Panel	03-3185.1	1			
		03-3185.2		1		
		03-3185.3			1	
		03-3185.4				1
90	3" Black Flanged Tee	53-2451	1	1	1	1
91	Pipe Connection Assy	70-3712	1			
		70-3713		1		
		70-3714			1	
		70-3753				1
92	8-1/2" x 4" Gasket (8 hole)	06-0145	1	1	1	1
93	Pipe Outlet Adapter	70-3708	1			
		70-3709		1		
		70-3751			1	1
94	Condensation Trap Assy	70-4009	1	1	1	1
95	Jacket Rear Back/Right Extension	70-3779.1	1			
		70-3779.2		1		
		70-3779.3			1	
		70-3779.4				1
	Jacket Rear Back/Left Extension	70-3778.1	1			
		70-3778.2		1		
		70-3778.3			1	
		70-3778.4				1
96	Economizer	12-2005	1	1		
		12-2004			1	1
97	Left/Right Base Channel	04-1151	2	2	2	2
98	Channel Insert	70-4134	2	2	2	2
99	Heat Exchanger Flat Bar	04-1161.1	2	2		
		04-1161.3			2	2
100	Junction Box Bracket	40-1096	1	1	1	1



# START-UP REPORT



DATE:	JOB NAME:
TECHNICIAN:	LOCATION:
COMPANY:	MODEL:
PHONE NUMBER:	SERIAL #:

## PRE-STARTUP CHECK LIST

- |                                                    |                                                                            |
|----------------------------------------------------|----------------------------------------------------------------------------|
| <input type="checkbox"/> NO VISIBLE DAMAGE TO UNIT | <input type="checkbox"/> INLET AIR FILTER INSTALLED AND CLEAN              |
| <input type="checkbox"/> PIPING PROPERLY CONNECTED | <input type="checkbox"/> PROPER SERVICE CLEARANCES PROVIDED                |
| <input type="checkbox"/> BOILER CIRCULATOR WIRED   | <input type="checkbox"/> PUMP RUNNING, HEAT EXCHANGER FULL                 |
| <input type="checkbox"/> VENT/STACK CONNECTED      | <input type="checkbox"/> GAS LINES PURGED, NO LEAKS, NO MISSING TEST PLUGS |

## BOILER STARTUP SEQUENCE

**Note:** Locate the AA terminals and minimum hold switch in the bottom-right of the electrical panel on the main HeatNet board. Also locate the manometer test manifold in the bottom of the electrical panel.

1. Disable any external call for heat and toggle the remote/local switch to REMOTE.
2. Toggle the LOW FIRE switch to cycle the boiler then hold at trial for pilot ignition.
3. Set pressure to 3–3.5 in WC (flame signal should read 5.0 VDC).
4. Release boiler to main flame trial for ignition.
5. Check for stable flame.
6. Record combustion and pressure signal (Ps) at minimum firing rate. (Reference Fusion XLF Boiler IOM.)
7. Jumper the AA terminals to force 100% input.
8. Record combustion and pressure signal (Ps). (Reference Fusion XLF Boiler IOM.)
9. Remove the AA jumper to place the boiler at minimum rate.
10. Check all combustion results using a calibrated flue gas analyzer.
11. Release the LOW FIRE switch to place boiler in standby.

**NOTICE**

In addition to completing the Futera Fusion XLF start-up report, complete the control set-up information in the rear of the HeatNet Control manual.

COMBUSTION ANALYSIS	MINIMUM FIRING RATE	100% FIRING RATE
GAS PRESSURE AT SUPPLY TEST PORT	INCHES WC	INCHES WC
CO <sub>2</sub>	%	%
O <sub>2</sub>	%	%
CO (PPM)	PPM	PPM
NET STACK TEMPERATURE	°F	°F
PRESSURE SIGNAL (Ps)	INCHES WC	INCHES WC

### SAFETY TEST CHECKLIST

- FLOW SWITCHES
- AIR SWITCH
- FLAME SAFEGUARD
- LOW WATER CUT-OFF
- HIGH LIMITS

**NOTICE** Verify that the piping and controls ensure the boiler return water temperature does NOT drop below **140°F, 60°C**. Operating at lower return temperatures is likely to cause condensation in the primary heat exchanger, resulting in corrosion and possible failure of the heat exchanger.

### COMMISSIONING THE BOILER

<ul style="list-style-type: none"> <li><input type="checkbox"/> UNIT CYCLED MINIMUM OF 15 TIMES</li> <li><input type="checkbox"/> CUSTOMER INSTRUCTED</li> <li><input type="checkbox"/> ALL COVERS REPLACED</li> <li><input type="checkbox"/> CUSTOMER GIVEN MANUAL</li> <li><input type="checkbox"/> TARGET TEMPERATURE SET PER CUSTOMER</li> </ul> <p>COMMISSIONED BY: _____ (SIGNATURE)</p> <p>DATE: _____</p>	<p>THE DELTA T BETWEEN THE HEATER IN-LET AND OUTLET IS CRITICAL TO PROPER FLOW. BEFORE YOU LEAVE THE JOBSITE, YOU MUST RECORD THE DELTA T. THIS READING SHOULD NOT EXCEED 35°F, 19.4°C, NOR BE LOWER THAN 20°F, 11.1°C.</p> <p style="text-align: center;">DELTA T = <input style="width: 100px; height: 20px;" type="text"/></p>
-----------------------------------------------------------------------------------------------------------------------------------------------------------------------------------------------------------------------------------------------------------------------------------------------------------------------------------------------------------------------------------------------------------------------	-----------------------------------------------------------------------------------------------------------------------------------------------------------------------------------------------------------------------------------------------------------------------------------------------------------------------------------

### ADDITIONAL NOTES AND COMMENTS

---



---



---



---



---



---



---

# NOTICE!

## Commonwealth of Massachusetts Installation Requirements

MACODE-3

**NOTICE**

In the Commonwealth of Massachusetts, the installation must be performed by a licensed plumber or gas fitter.

1. For all side wall horizontally vented gas fueled equipment installed in every dwelling, building or structure used in whole or in part for residential purposes, including those owned or operated by the commonwealth and where the side wall exhaust vent termination is less than seven (7) feet above finished grade, in the area of the venting, including but not limited to decks and porches, the following requirements shall be satisfied:
  - d. **INSTALLATION OF CARBON MONOXIDE DETECTORS.** At the time of installation of the side wall horizontal vented gas fueled equipment, the installing plumber or gasfitter shall observe that a hard wired carbon monoxide detector with an alarm and battery back-up is installed on the floor level where the gas equipment is to be installed. In addition, the installing plumber or gasfitter shall observe that a battery operated or hard wired carbon monoxide detector with an alarm is installed on each additional level of the dwelling, building or structure served by the side wall horizontal vented gas fueled equipment. It shall be the responsibility of the property owner to secure the services of qualified licensed professionals for the installation of hard wired carbon monoxide detectors.
    - i. In the event that the side wall horizontally vented gas fueled equipment is installed in a crawl space or an attic, the hard wired carbon monoxide detector with alarm and battery back-up may be installed on the next adjacent floor level.
    - ii. In the event that the requirements of this subdivision can not be met at the time of completion of installation, the owner shall have a period of thirty (30) days to comply with the above requirements; provided, however, that during said thirty (30) day period, a battery operated carbon monoxide detector with an alarm shall be installed.
  - e. **APPROVED CARBON MONOXIDE DETECTORS.** Each carbon monoxide detector as required in accordance with the above provisions shall comply with NFPA 720 and be ANSI/UL 2034 listed and IAS certified.
  - f. **SIGNAGE.** A metal or plastic identification plate shall be permanently mounted to the exterior of the building at a minimum height of eight (8) feet above grade directly in line with the exhaust vent terminal for the horizontally vented gas fueled heating appliance or equipment. The sign shall read, in print size no less than one-half (1/2) inch in size, "GAS VENT DIRECTLY BELOW. KEEP CLEAR OF ALL OBSTRUCTIONS".
  - g. **INSPECTION.** The state or local gas inspector of the side wall horizontally vented gas fueled equipment shall not approve the installation unless, upon inspection, the inspector observes carbon monoxide detectors and signage installed in accordance with the provisions of 248 CMR 5.08(2)(a)1 through 4.

**WARNING**

Improper venting can result in excessive levels of carbon monoxide which can cause severe personal injury or death!

2. Exemptions — The following equipment is exempt from 248 CMR 5.08(2)(a) 1 through 4:
  - a. The equipment listed in Chapter 10 entitled "Equipment Not Required To Be Vented" in the most current edition of NFPA 54 as adopted by the Board; and
  - b. Product Approved side wall horizontally vented gas fueled equipment installed in a room or structure separate from the dwelling, building or structure used in whole or in part for residential purposes.
3. **MANUFACTURER REQUIREMENTS - GAS EQUIPMENT VENTING SYSTEM PROVIDED.**
  - a. When the manufacturer of Product Approved side wall horizontally vented gas equipment provides a venting system design or venting system components with the equipment, the instructions provided by the manufacturer for installation of the equipment and the venting system shall include:
    - i. Detailed instructions for the installation of the venting system design or the venting system components; and
    - ii. A complete parts list for the venting system design or venting system.
4. **MANUFACTURER REQUIREMENTS – GAS EQUIPMENT VENTING SYSTEM NOT PROVIDED.**
  - a. When the manufacturer of a Product Approved side wall horizontally vented gas fueled equipment does not provide the parts for venting the flue gases, but identifies "special venting systems", the following requirements shall be satisfied by the manufacturer:
    - i. The referenced "special venting system" instructions shall be included with the appliance or equipment installation instructions; and
    - ii. The "special venting systems" shall be Product Approved by the Board, and the instructions for that system shall include a parts list and detailed installation instructions.
5. A copy of all installation instructions for all Product Approved side wall horizontally vented gas fueled equipment, all venting instructions, all parts lists for venting instructions, and/or all venting design instructions shall remain with the appliance or equipment at the completion of the installation.

**WARNING**

Improper venting can result in excessive levels of carbon monoxide which can cause severe personal injury or death!

## LIMITED WARRANTY

### Boilers Industrial, Commercial and Other Non-Residential Use

The "Manufacturer" warrants to the original owner at the original installation site that the heat exchanger of the Industrial, Commercial, and other Non-Residential Use Boiler (the "Product") will be free from defects in material or workmanship for ten (10) years from the date of installation. Additional twenty one (21) year thermal shock warranty on heat exchanger. If upon examination by the Manufacturer the Product is shown to have a defect in material or workmanship during the warranty period, the Manufacturer will repair or replace, at its option, that part of the Product which is shown to be defective. All other RBI supplied Boiler parts are warranted against defects in material and workmanship for one (1) year from date of installation or 18 months from date of shipment from RBI.

This limited warranty does not apply:

- (a) if the Product has been subjected to misuse or neglect, has been accidentally or intentionally damaged, has not been installed, maintained or operated in accordance with the furnished written instructions, or has been altered or modified in any way.

These include but not limited to:

- Excessive water hardness causing a lime build-up in the heat exchanger tubes is not a fault of the equipment and is not covered under the manufacturer's warranty.
  - Excessive pitting and erosion on the inside of the heat exchanger tubes caused by high water velocity through the tubes and is not covered by the manufacturer's warranty. (See Installation Instructions for proper pump performance.)
  - Chemical corrosion, no corrosive chemical (freon, dry cleaning chemicals, degreasing liquids, chlorine or any chemicals that produce hydrochloric acid) can be present in the boiler room as it rapidly destroys the heating equipment and voids the warranty.
  - All copper fin boilers should not operate with a return water temperature less than 110°F, 43°C atmospheric combustion, 125°F, 52°C fan assist combustion. If a lower temperature is required, an external bypass should be installed to prevent condensation (bypass and valve arrangement included on the Futera Fusion Series). The manufacturer's warranty does not cover damage done by condensation.
- (b) to any expenses, including labor or material, incurred during removal or reinstallation of the Product or parts thereof.
- (c) to damage as a result of settlement, distortion, collapse, or cracking of any foundation area, beams or pipes surrounding the Product.
- (d) to any workmanship of any installer of the Product; or to Products installed outside the continental United States or Canada.

This limited warranty is conditional upon:

- (a) shipment, to the Manufacturer, of that part of the Product thought to be defective. Goods can only be returned with prior written approval from the Manufacturer. All returns must be freight prepaid.
- (b) determination in the reasonable opinion of the Manufacturer that there exists a defect in material or workmanship.

Repair or replacement of any part under this Limited Warranty shall not extend the duration of the warranty with respect to such repaired or replaced part beyond the stated warranty period.

**THIS LIMITED WARRANTY IS IN LIEU OF ALL OTHER WARRANTIES, EITHER EXPRESS OR IMPLIED, AND ALL SUCH OTHER WARRANTIES, INCLUDING WITHOUT LIMITATION IMPLIED WARRANTIES OF MERCHANTABILITY OR FITNESS FOR A PARTICULAR PURPOSE, ARE HEREBY DISCLAIMED AND EXCLUDED FROM THIS LIMITED WARRANTY. IN NO EVENT SHALL THE MANUFACTURER BE LIABLE IN ANY WAY FOR ANY CONSEQUENTIAL, SPECIAL, OR INCIDENTAL DAMAGES OF ANY NATURE WHATSOEVER, OR FOR ANY AMOUNTS IN EXCESS OF THE SELLING PRICE OF THE PRODUCT OR ANY PARTS THEREOF FOUND TO BE DEFECTIVE. THIS LIMITED WARRANTY GIVES THE ORIGINAL OWNER OF THE PRODUCT SPECIFIC LEGAL RIGHTS. YOU MAY ALSO HAVE OTHER RIGHTS WHICH MAY VARY BY EACH JURISDICTION.**



260 North Elm Street  
Westfield, MA 01085  
Phone: (413) 568-9571  
Fax: (413) 568-9613

7555 Tranmere Drive  
Mississauga, Ontario L5S 1L4 Canada  
Phone: (905) 670-5888  
Fax: (905) 670-5782

[www.rbiwaterheaters.com](http://www.rbiwaterheaters.com)

