

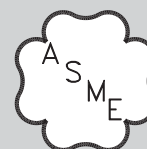

Finned Copper Tube Gas Boilers (MB) & Water Heaters (MW)

Boiler Manual *Installation and Operation Instructions*

Also read and follow:
HeatNet® Control Manual



WARNING This manual is intended only for use by a qualified heating installer/technician. Read and follow this manual, all supplements and related instructional information provided with the boiler. Install, start and service the boiler only in the sequence and methods given in these instructions. Failure to do so can result in severe personal injury, death or substantial property damage.

WARNING **Do not use the boiler during construction.** Construction dust and particulate, particularly drywall dust, will cause contamination of the burner, resulting in possible severe personal injury, death or substantial property damage. The boiler can only be operated with a dust-free air supply. Follow the instruction manual procedures to duct air to the boiler air intake. If the boiler has been contaminated by operation with contaminated air, follow the instruction manual guidelines to clean, repair or replace the boiler if necessary.

CAUTION Affix these instructions near to the boiler. Instruct the building owner to retain the instructions for future use by a qualified service technician, and to follow all guidelines in the User's Information Manual.

WARNING If the information in this manual is not followed exactly, a fire or explosion may result causing property, personal injury or loss of life.

Do not store or use gasoline or other flammable vapors and liquids in the vicinity of this or any other appliance

WHAT TO DO IF YOU SMELL GAS:

- Do not try to light any appliance.
- Do not touch any electrical switch. Do not use any phone in your building.
- Immediately call your gas supplier from a neighbor’s phone. Follow the gas supplier’s instructions.
- If you cannot reach your gas supplier, call the fire department.

Installation and service must be performed by a qualified installer, service agency or the gas supplier.

WARNING Assurez-vous de bien suivre les instructions données dans cette notice pour réduire au minimum le risque d’incendie ou d’explosion ou pour éviter tout dommage matériel, toute blessure ou la mort

Ne pas entreposer ni utiliser d’essence ou ni d’autres vapeurs ou liquides inflammables à proximité de cet appareil ou de tout autre appareil.

QUE FAIRE SI VOUS SENTEZ UNE ODEUR DE GAZ:

- Ne pas tenter d’allumer d’appareil.
- Ne touchez à aucun interrupteur; ne pas vous servir des téléphones se trouvant dans le bâtiment.
- Appelez immédiatement votre fournisseur de gaz depuis un voisin. Suivez les intructions du fournisseur.
- Si vous ne pouvez rejoindre le fournisseur, appelez le service des incendies.

L’installation et l’entretien doivent être assurés par un installateur ou un service d’entretien qualifié ou par le fournisseur de gaz.

WARNING Failure to properly vent this unit can cause excessive amounts of carbon monoxide resulting in severe personal injury or death!

DESIGNED AND TESTED ACCORDING TO A.S.M.E. BOILER AND PRESSURE VESSEL CODE, SECTION IV FOR A MAXIMUM ALLOWABLE WORKING PRESSURE OF 160 PSI, 1103 kPa WATER.

BEFORE YOU START 2

RATINGS & CAPACITIES 3

BOILER/WATER HEATER LOCATION 3

COMBUSTION AIR & VENTILATION 3

GENERAL VENTING GUIDELINES. 5

OUTDOOR VENTING.10

COMMON VENT SYSTEMS11

GENERAL PIPING REQUIREMENTS12

HEATING SYSTEM PIPING13

DOMESTIC WATER SUPPLY PIPING17

GAS SUPPLY PIPING20

ELECTRICAL WIRING21

GENERAL OPERATION21

OPERATING INSTRUCTIONS22

SEQUENCE OF OPERATION24

CHECKING & ADJUSTMENTS.25

HEATNET FIELD WIRING26

CONTROL DESCRIPTION28

DIAGNOSTIC28

MAINTENANCE31

TROUBLE-SHOOTING33

REPAIR PARTS34

START-UP SHEET40

MASS CODE42

WARRANTY43

BEFORE YOU START

This manual covers the application, installation, operation and maintenance of a Futera III Series finned copper heating boiler/water heater/pool heater (Canada only). To obtain the safe, dependable, efficient operation and long life for which this heating boiler/water heater was designed, these instructions must be read, understood and followed.

The Futera III Series finned copper heating boiler/water heaters have been design certified by CSA for use with natural and propane gas under the latest revision of ANSI-Z21.10.3/CSA 4.3, Gas Water Heaters, ANSI-Z21.13/CSA 4.9, Gas-Fired Low Pressure Steam and Hot Water Boilers ANSI-Z21.56/CSA 4.7 Gas-Fired Pool Heaters (Canada only) and CAN1-3.1, Industrial and Commercial Gas Fired Packaged Boilers. Each unit has been constructed and hydrostatically tested for a maximum working pressure of **160 psi, 1103 kPa** in accordance with Section IV of the A.S.M.E. Boiler and Pressure Vessel Code.

All aspects of the boiler/water heater installation must conform to the requirements of the authority having jurisdiction, or, in the absence of such requirements, to the National Fuel Gas Code, ANSI Z223.1/NFPA 54 latest revision. Where required by the authority having jurisdiction, the installation must conform to the Standard for Controls and Safety Devices for Automatically Fired Boilers, ANSI/ASME CSD-1.

In Canada, the installation must be in accordance with the requirements of CSA B149.1 or .2, Installation Code for Gas Burning Appliances and Equipment.

If installed in the Commonwealth of Massachusetts, you MUST FOLLOW the additional instructions contained in RBI's instruction sheet MACODE-3. Which is located in the back of this manual.

The owner should maintain a record of all service work performed with the date and a description of the work done. Include the name of the service organization for future reference.

Direct all questions to your RBI distributor or contact the RBI Customer Service Department at: 260 North Elm Street, Westfield, MA 01085 for US or 7555 Tranmere Drive, Mississauga ONT L5S 1L4 for Canada. Always include the model and serial numbers from the rating plate of the boiler/water heater in question.

RATINGS & CAPACITIES

Before undertaking the installation of the Futera III Series boiler/water heater check the rating plate to ensure that the unit has been sized properly for the job. The "Net I=B=R Ratings" specify the equivalent amount of direct copper radiation that the unit can supply under normal conditions. Also ensure that the unit has been set up for the type of gas available at the installation site. Other important considerations are the availability of an adequate electrical supply, fresh air for combustion and a suitable chimney or vent system.

BOILER/WATER HEATER LOCATION

1. This boiler/water heater is suitable for indoor and outdoor installations. Locate the boiler/water heater in an area that provides good access to the unit. Servicing may require the removal of jacket panels. Allow the minimum clearances between adjacent construction and the boiler/water heater as listed in Table 1.

NOTICE Service clearances are not mandatory, but are recommended to ensure ease of service should it be required.

Table 1

	Clearance to Combustibles		Service Clearance	
	in	mm	in	mm
Top	6	153	30	762
Back	6	153	24	610
Left Side	6	153	12	306
Right Side	6	153	12	306
Front	6	153	30	762

2. An optimum site will be level, central to the piping system, close to a chimney or outside wall and have adequate fresh air for combustion. Ensure that the boiler/water heater is level from front to back and from side to side. Use metal shims to level the boiler/water heater. Electrical and electronic components must also be protected from exposure to water during operation and maintenance. DO NOT install this boiler/water heater in a location that would subject any of the gas ignition components to direct contact with water or excessive moisture during operation or servicing.
3. Ensure that the floor is structurally sound and will support the weight of the boiler/water heater.

NOTICE The Futera III may be installed directly on combustible flooring, but never on carpeting.

4. Locate the boiler/water heater in an area that will prevent water damage to adjacent construction should a leak occur or during routine maintenance. If such a location doesn't exist, a suitable drain pan that's adequately drained must be installed under the unit.
5. DO NOT place this boiler/water heater in a location that would restrict the introduction of combustion air into the unit or subject it to a negative pressure, see "GENERAL VENTING GUIDELINES".
6. NEVER place this boiler/water heater in a location that would subject it to temperatures at or near freezing, see the "FREEZE PROTECTION" section on page 12.

WARNING Never store combustible materials, gasoline or any product containing flammable vapors or liquids in the vicinity of the boiler/water heater. Failure to comply with this warning can result in an explosion or fire causing extensive property damage, severe personal injury or death!

COMBUSTION AIR & VENTILATION

WARNING This boiler/water heater must be supplied with combustion air in accordance with Section 5.3, Air for Combustion & Ventilation, of the latest revision of the National Fuel Gas Code, ANSI Z223.1/NFPA 54 and all applicable local building codes. Canadian installations must comply with CAN/CGA B149.1 or .2 Installation Code for Gas Burning Appliances and Equipment, or applicable provisions of the local building codes. Failure to provide adequate combustion air for this boiler/water heater can result in excessive levels of carbon monoxide which can result in severe personal injury or death!

To operate properly and safely this boiler/water heater requires a continuous supply of air for combustion. NEVER store objects on or around the boiler/water heater!

CAUTION Combustion air contaminated with fluorocarbons or other halogenated compounds such as cleaning solvents and refrigerants will result in the formation of acids in the combustion chamber. These acids will cause premature failure of the boiler/water heater voiding the warranty!

CAUTION If the boiler/water heater is operated while the building is under construction it **MUST** be protected from wood, concrete, sheet rock and other types of dust. Failure to properly protect the unit from construction dust will damage the unit voiding the warranty!

Buildings will require the installation of a fresh air duct or other means of providing make-up air if the intake air option isn't used. Any building utilizing other gas burning appliances, a fireplace, wood stove or any type of exhaust fan must be checked for adequate combustion air when all of these devices are in operation at one time. Sizing of an outside air duct must be done to meet the requirements of all such devices.

WARNING Never operate the Futera III in an environment subjected to a negative pressure unless it is Direct Vented. Failure to comply with this warning can result in excessive levels of carbon monoxide causing severe personal injury or death!

All Air From Inside The Building

If the Futera III is to be located in a confined space, the minimum clearances listed in Table 1 must be maintained between it and any combustible construction. When installed in a confined space **without the intake air option**, Figures 5, 6 and 7, two permanent openings communicating with an additional room(s) are required. The combined volume of these spaces must have sufficient volume to meet the criteria for an unconfined space. The total air requirements of all gas utilization equipment, fireplaces, wood stoves or any type of exhaust fan must be considered when making this determination. Each opening must have a minimum free area of **1 in²/1000 Btu/hr, 2200 mm²/kW** based on the total input rating of ALL gas utilization equipment in the confined area. Each opening must be no less than **100 in², 64,516 mm²** in size. The upper opening must be within **12 in, 305 mm** of, but not less than **3 in, 76 mm** from, the top of the enclosure. The bottom opening must be within **12 in, 305 mm** of, but not less than **3 in, 76 mm** from, the bottom of the enclosure.

All Air From Outside The Building

When installed in a confined space **without utilizing the intake air option** two permanent openings communicating directly with, or by ducts to, the outdoors or spaces that freely communicate with the outdoors must be present. The upper opening must be within **12 in, 305 mm** of, but not less than **3 in, 76 mm** from, the top of the enclosure. The bottom opening must be within **12 in, 305 mm** of, but not less than **3 in, 76 mm** from, the bottom of the enclosure.

Where directly communicating with the outdoors or communicating with the outdoors through vertical ducts, each opening shall have a minimum free area of **1 in²/4000 Btu/hr, 550 mm²/kW** of the total input rating of all of the equipment in the enclosure.

Where communicating with the outdoors through horizontal ducts, each opening shall have a minimum free area of **1 in²/2000 Btu/hr, 1100 mm²/kW** of the total input rating of all of the equipment in the enclosure.

When ducts are used, they must have the same cross-sectional area as the free area of the opening to which they connect.

When calculating the free area necessary to meet the make-up air requirements of the enclosure, consideration must be given to the blockage effects of louvers, grills and screens. Screens must have a minimum mesh size of **1/4 in, 6.4 mm**. If the free area through a louver or grill is not known, ducts should be sized per Table 2.

Canadian installations must comply with CSA B149.1 when **air supply** is provided by natural air flow from the outdoors for **natural draft**, partial fan-assisted, fan-assisted, or power draft-assisted **burners**, there shall be a permanent **air supply** opening(s) having a cross-sectional area of not less than **1 in² per 7,000 Btuh (310 mm² per kW)** up to **and including 1 million Btuh**, plus **1 in² per 14,000 Btuh (155 mm² per kW)** in excess of **1 million Btuh**.

Table 2 Make-up Air Louver Sizing

Input (MBH)	Required Cross Sectional Area					
	1/4 in 6.4 mm Wire Screen		75% Free Area Metal Louvers		25% Free Area Wooden Louvers	
	in ²	cm ²	in ²	cm ²	in ²	cm ²
500	125	806	167	1077	500	3226
750	187	1206	250	1613	750	4839
1000	250	1613	333	2148	1000	6452
1250	313	2019	416	2684	1250	8065
1500	375	2419	500	3226	1500	9677
1750	437	2819	583	3761	1750	11,290
1999	500	3226	667	4303	2000	12,900

Intake Air Option – General Guidelines

This configuration provides combustion air directly to the boiler/water heater's air intake adapter using a dedicated pipe when using the direct vent option. Combustion air can be drawn in horizontally through the same outside wall which terminates the exhaust gases or vertically through the roof, see Figures 1, 2, 3 & 4.

WARNING Common intake air systems may be used provided the common duct is sized properly. An intake combustion air damper should be installed if the common vent option is used in the intake air pipe of each heater. Improper installation can result in excessive levels of carbon monoxide which can cause severe personal injury or death!

Single wall galvanized smoke pipe, single wall aluminum pipe, flexible aluminum pipe, PVC or CPVC pipe can be used for the intake air pipe. It must be sized per Table 3.

Table 3 Intake Air Pipe Sizing

Model Size	For Vertical (Up to 60')		For Horizontal (Up to 60')	
	in	mm	in	mm
500	8	203	6	152
750	8	203	6	152
1000	8	203	6	152
1250	10	254	8	203
1500	10	254	10	254
1750	12	305	12	305
2000	12	305	12	305

All joints in metal intake air systems must be secured using corrosion resistant fasteners and sealed using a suitable Silicone caulk. If PVC or CPVC is used, the joints must be cleaned with a suitable solvent and connected using a solvent based PVC cement. **The combustion air system MUST be supported by the building structure not the boiler/water heater.**

CAUTION A combustion air damper interlocked with the unit should be installed in the intake air pipe when the infiltration of subfreezing air could occur, otherwise the unit could freeze up voiding the warranty!

Intake Air Option – Vertical Guidelines

The maximum equivalent length for the vertical intake air pipe is **60 ft, 18.3 m**. Each 90° elbow and the intake air terminal are equal to **10 linear ft, 3.0 m** of pipe, see Table 3.

An approved, nonrestrictive intake air terminal must be used. The intake air terminal must terminate as shown in Figure 3. The penetration point in the roof must be properly flashed and sealed.

Intake Air Option – Horizontal Guidelines

The maximum equivalent length for the horizontal intake air pipe is **60 ft, 18.3 m**. Each 90° elbow and the intake air terminal are equal to 10 linear ft, 3.0 m of pipe. If horizontal runs exceed **5 ft, 1.5 m** they must be supported at **3 ft, 0.9 m** intervals with overhead hangers. The certified intake air terminal from RBI must be used, see Figures 1, 2 and 4.

GENERAL VENTING GUIDELINES

WARNING The vent installation must be in accordance with Part 7, Venting of Equipment, of the National Fuel Gas Code, ANSI Z223.1/NFPA 54-latest revision or applicable provisions of the local building codes. Canadian installations must comply with CAN/CGA B149.1 or .2 Installation Code. Improper venting can result in excessive levels of carbon monoxide which can result in severe personal injury or death!

All vent systems must be fully supported by the building structure and not by the boiler/water heater. Appropriate thimbles and fire-stops must be used where required.

WARNING Common vent systems must be properly engineered and sized to provide a negative draft of .03 in, 0.8 mm to .1 in, 2.5 mm W.C. at the flue outlet. Common positive pressure vent systems are not to be used. Improper installation can result in excessive levels of carbon monoxide which can cause severe personal injury or death!

VENT SYSTEM OPTIONS – (CATEGORY I, II, IV)

WARNING Correctly identify the type of vent system the appliance requires before proceeding. Category identification is noted on the unit rating plate.

The flue products in the vent system may be cooled below their dew point and form condensate in the flue. The materials used for a **Category II and IV** vent must be resistant to any corrosive damage from flue gas condensate. The flue from a **Category II and IV** vent system must have a condensate drain with provisions to properly collect and dispose of any condensate that may occur in the venting system.

The Futera III may be vented the following ways:

- 1) **Direct Vent, Positive Pressure, Category IV** uses a vent system certified to UL 1738 for installations in the United States, ULC S636 for installations in Canada. Combustion air is piped from the outdoors to the blower inlet.
- 2) **Side Wall Vent, Positive Pressure, Category IV** uses a vent system certified to UL 1738 for installations in the United States, ULC S636 for installations in Canada. Combustion air is obtained from the space in which the unit is installed.
- 3) **Vertical/Chimney Vent, Negative Pressure, Category II** uses a metal chimney system approved for Category II.
- 4) **Vertical Vent, Positive Pressure, Category IV** uses a vent system certified to UL 1738 for installations in the United States, ULC S636 for installations in Canada. Combustion air is obtained from the outdoors or the space in which the unit is installed.
- 5) **Vertical Vent/Chimney Vent (750-2000), Negative Pressure Non-Condensing, Category I** uses an approved metal chimney system or masonry chimney. Combustion air is obtained from the space in which the unit is installed.

NOTICE All venting and combustion air material supplied by installer. All venting materials must be approved for the application. Consult the vent manufacturer's product literature.

WARNING The maximum equivalent length for the flue outlet vent system for Category IV conditions is **60 ft, 18.3 m**. Use Table 4 for the equivalent lengths per fitting. Table 4 "Category Equivalent Length Per Fitting" chart is meant as a guideline for preliminary sizing. If vent length approaches 75% of maximum length listed an engineered vent system calculation must be performed, consult factory.

ANSI Categorization

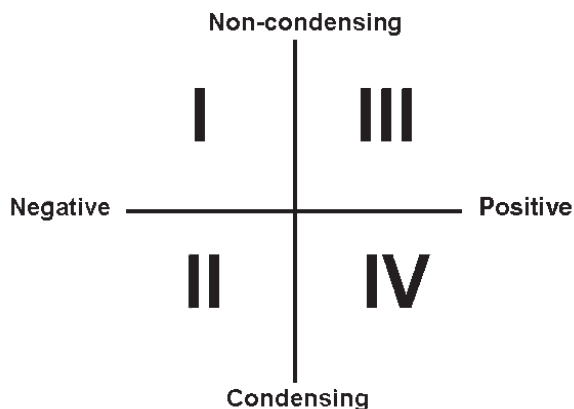

DIRECT VENT, POSITIVE PRESSURE, CATEGORY IV

In this configuration the boiler/water heater blower is used to push the flue products to the outdoors while drawing combustion air from the outdoors. The Intake Air Option instructions under the “COMBUSTION AIR & VENTILATION” section must be followed! The vent system must be sized per Table 4.

Table 4 Category IV

Model/ Outlet Diameter	K	Equivalent Feet of Straight Pipe (ft)		
		500 5"	750 5"	1000 6"
Standard Tee	1.25	15 ft	20 ft	25 ft
Boot Tee	0.65	10 ft	10 ft	15 ft
Cap - Low Res. (UL)	0.50	10 ft	10 ft	10 ft
45° w/Bird Screen	0.40	7 ft	7 ft	10 ft
Elbow – 90°	0.38	10 ft	10 ft	10 ft
Elbow – 45°	0.15	5 ft	5 ft	5 ft

Model/ Outlet Diameter	K	Equivalent Feet of Straight Pipe (ft)			
		1250 6"	1500 8"	1750 10"	2000 10"
Standard Tee	1.25	25 ft	35 ft	40 ft	40 ft
Boot Tee	0.65	15 ft	15 ft	20 ft	20 ft
Cap - Low Res. (UL)	0.50	10 ft	10 ft	15 ft	15 ft
45° w/Bird Screen	0.40	10 ft	10 ft	10 ft	10 ft
Elbow – 90°	0.38	10 ft	10 ft	15 ft	15 ft
Elbow – 45°	0.15	5 ft	5 ft	5 ft	5 ft

Horizontal Direct Vent Systems Figures 1 & 2

The vent materials used in horizontal vent systems must be certified to UL 1738 for installations in the United States, ULC S636 for installations in Canada. The certified vent terminal from RBI must also be used.

If any part of a single wall metal vent system passes through an unheated space, it must be insulated with insulation rated for 400°F, 204°C. Structural penetrations must be made using approved fire-stops. For best results, horizontal vent systems should be as short and straight as possible.

The vent system must be both gas tight and watertight. All seams and joints in metal pipes must be joined and sealed in accordance with the vent system manufacturer’s instructions.

When horizontal vent runs exceed 5 ft, 1.5 m they must be supported at 3 ft, 0.9 m intervals with overhead hangers. The vent system must be pitched down, toward the vent terminal, 1/4 in/ft, 20 mm/m. If any part of a single wall metal vent system passes through an unheated space it must be insulated with insulation rated for 400°F, 204°C.

Horizontal vent systems shall terminate at least 4 ft, 1.2 m below, 4 ft, 1.2 m horizontally from or 1 ft, 0.30 m above any door, window or gravity air inlet into any building. It must not terminate less than 4 ft, 1.2 m horizontally from, and in no case above or below, unless a 4 ft, 1.2 m horizontal distance is maintained, from electric meters, gas meters, regulators and relief equipment and not less than 7 ft, 2.1 m above adjacent public walkway. The bottom of the vent terminal(s) shall be located at least 5 ft, 1.5 m above the air intake terminal(s) unless there is a minimum 5 ft, 1.5 m horizontal separation between them. Avoid terminal locations likely to be affected by winds, snowdrifts, people and pets. Protect building materials and vegetation from degradation caused by the flue gases.

Vertical Direct Vent Systems – Figure 3

If any part of a single wall metal vent system passes through an unheated space, it must be insulated with insulation rated for 400°F, 204°C. Structural penetrations must be made using approved fire-stops.

An approved, nonrestrictive vent terminal must be used. The top of a vertical vent system must extend at least 5 1/2 ft, 1.7 m above the roof surface and maximum snow line that it passes through, 4 ft, 1.2 m above the intake air terminal, see Figure 3.

In addition the vent system must conform to the dimensions shown in Figure 3. The penetration point in the roof must be properly flashed and sealed.

The vent system must be gas tight. All seams and joints in metal pipes must be joined and sealed in accordance with the vent system manufacturer’s instructions.

Combination Direct Vent Systems – Figure 4

The boiler/water heater can be vented vertically with the intake air piped horizontally through an outside wall. Follow the instructions in the Intake Air Option – Horizontal Guidelines on page 5. Also follow the general instructions in the “COMBUSTION AIR & VENTILATION” and “GENERAL VENTING GUIDELINES” sections.

Figure 1 Horizontal Air Intake and Venting for a Single Direct Vent System (Category IV)

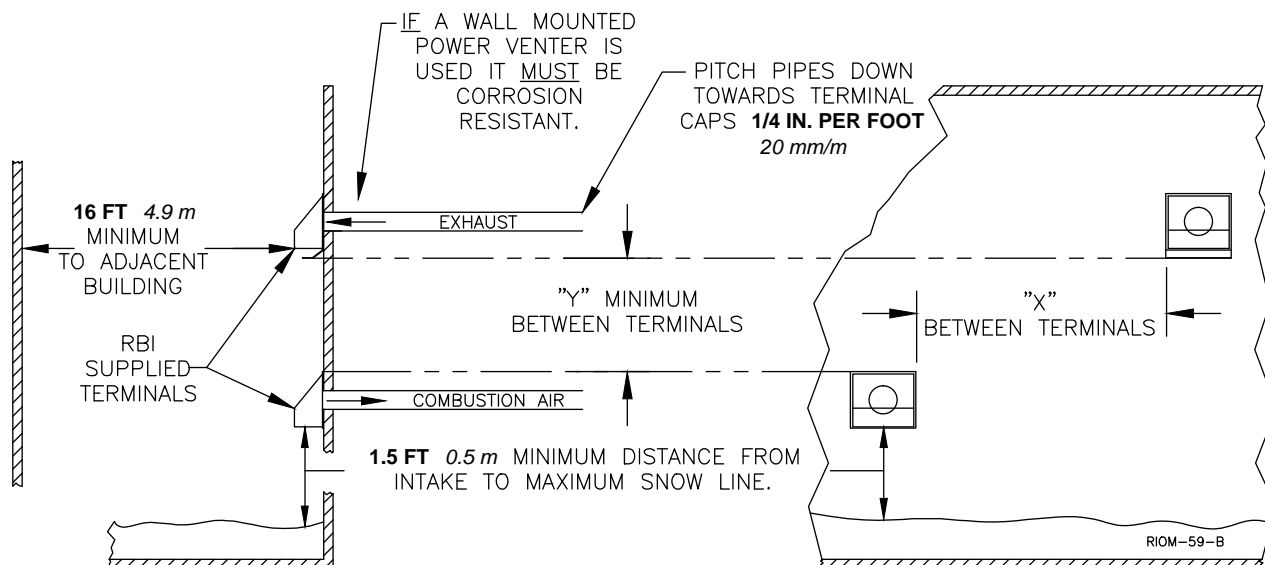

When running horizontal combustion air and venting for single or multiple units, exhaust and combustion air terminals must be installed on the same plane (outside wall) in order to prevent pressure differences due to prevailing winds. In cold climates, double-wall or insulated inlet pipe recommended to prevent condensation.

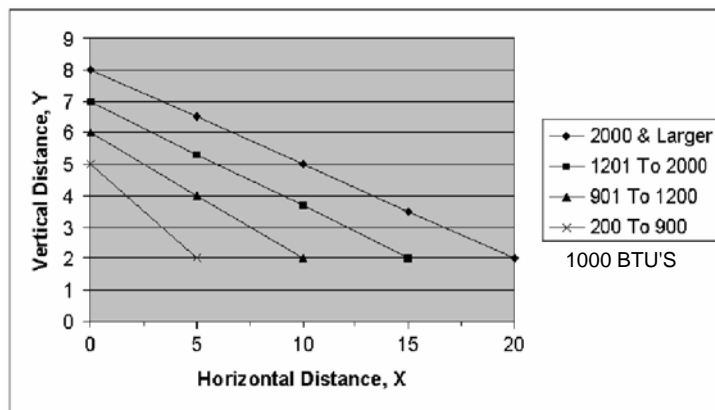

Figure 2 Horizontal Air Intake and Venting for Multiple Direct Vent Systems (Category IV)

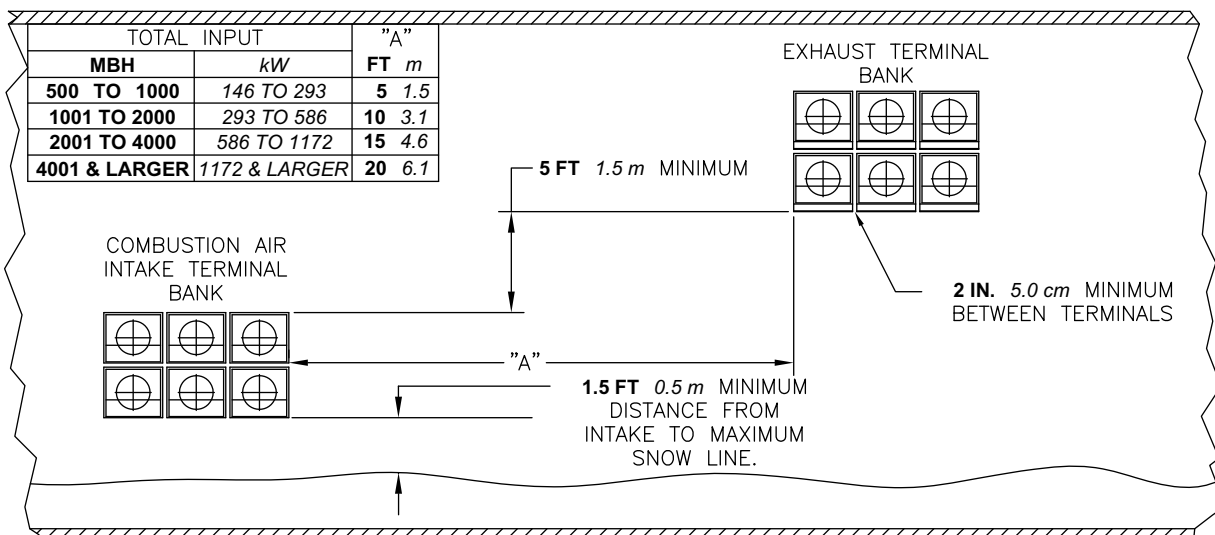

Figure 3 Vertical Air Intake and Venting for a Direct Vent System (Category IV)

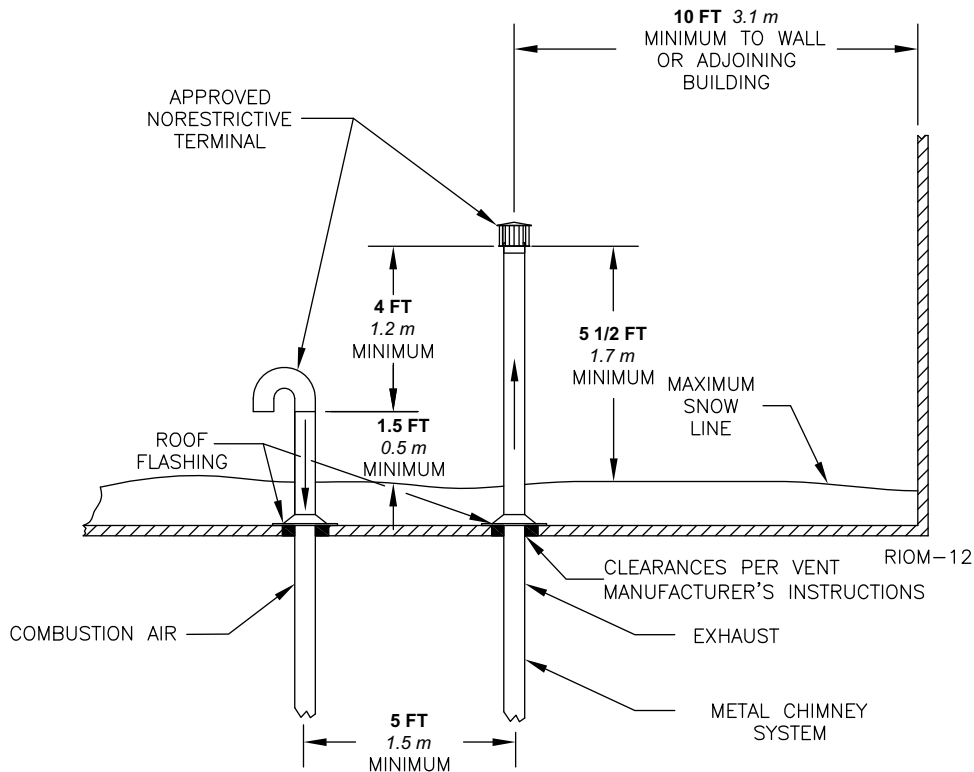
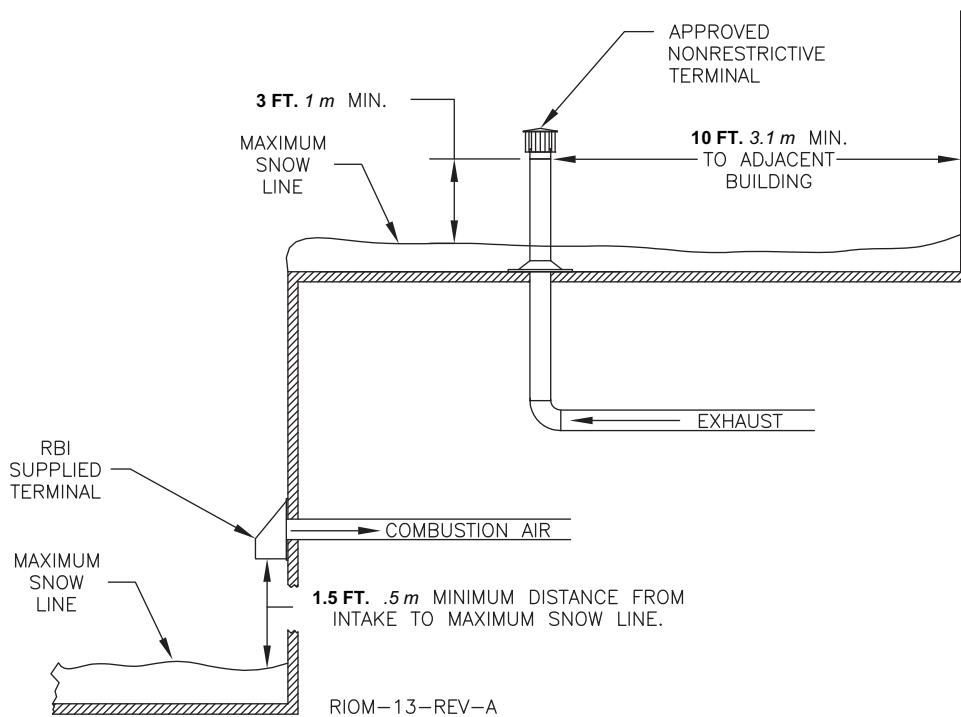

Figure 4 Combination Direct Vent Systems (Category IV)



SIDE WALL VENT, POSITIVE PRESSURE, CATEGORY IV – Figure 5

In this configuration the boiler/water heater blower is used to push the flue products horizontally to the outdoors, see Figure 5. The air for combustion is taken from the space in which the unit is installed. The applicable instructions under the “COMBUSTION AIR & VENTILATION” section must be followed! The vent guidelines under the Horizontal Direct Vent Systems section must also be followed.

VERTICAL VENT, POSITIVE PRESSURE, CATEGORY IV – Figures 7 & 9

(Vent pipe equivalent length up to **60 ft, 18.3 m** maximum)

WARNING Masonry chimneys, when used, must be lined with a metal liner certified for Category IV venting.

A thorough inspection of the masonry chimney must be performed to ensure that the chimney is clean, properly constructed lined, and sized. Exterior masonry chimneys should not be used unless properly lined to prevent condensation and draft problems.

VERTICAL VENT, NEGATIVE PRESSURE – CATEGORY I & II

The Futera III when listed as a Category II appliance and vented vertically into a listed metal chimney system, Figures 7 & 9. The chimney must provide a **negative** pressure not greater than **0.10 in, 2.5 mm W.C.** at the boiler/water heater flue collar with the unit running. The Futera III when listed as a Category I appliance and vented vertically into a listed metal chimney system, Figures 6 & 8. The chimney must provide a **negative** pressure not greater than **0.01 to 0.10 in, 0.25 to 2.0 mm W.C.** at the boiler/water heater flue collar with the unit running. A barometric damper must be installed between the flue collar and the vent connector when negative pressures exceed **0.10 in, 2.5 mm W.C.**

NOTICE When using a listed metal chimney system the chimney system manufacturer’s instructions must be followed.

WARNING Masonry chimneys, when used with Category II appliances, must be lined with a metal liner certified to UL 1738 for installations in the United States and ULC S636 for installations in Canada.

When more than one appliance is connected to the same chimney flue, the flue must be large enough to safely vent the combined output of all of the appliances.

WARNING If an appliance using any type of a mechanical draft system operating under positive pressure is connected to a chimney flue, never connect any other appliances to this flue. Doing so can result in excessive levels of carbon monoxide which can cause severe personal injury or death!

Figure 5 Side Wall Venting (Category IV)

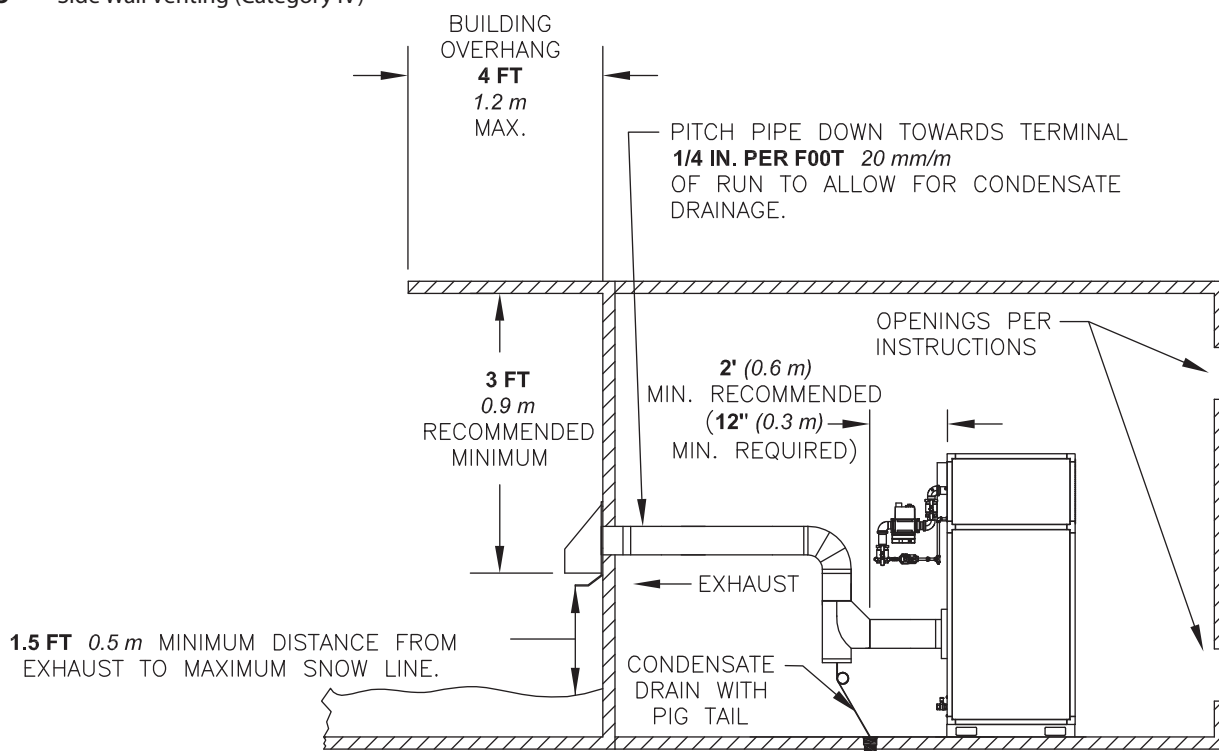

Chimney Inspection & Sizing – Category I and II

A thorough inspection of the masonry chimney must be performed to ensure that the chimney is clean, properly constructed, lined and sized. Exterior masonry chimneys should not be used unless properly lined to prevent condensation and draft problems. Tables 5 & 6 list the equivalent breaching and flue sizes required for the boiler/water heater.

WARNING Correctly identify the type of vent system the appliance requires before proceeding. Category identification is noted on the unit rating label.

Table 5 Equivalent Breaching & Chimney Size, Negative Pressure (Category I)

Model Size	Pipe Diameter	
	in	mm
500	–	–
750	8	203
1000	10	254
1250	10	254
1500	10	254
1750	12	305
2000	12	305

Note: These sizes are based on a 20 ft, 6.1m chimney height.

Table 6 Equivalent Breaching & Chimney Size, Negative Pressure (Category II)

Model Size	Pipe Diameter	
	in	mm
500	6	152
750	6	152
1000	7	178
1250	8	203
1500	8	203
1750	10	254
2000	10	254

Note: These sizes are based on a 20 ft, 6.1m chimney height.

Figure 6 Vertical Venting with a Metal Chimney System (Category I)

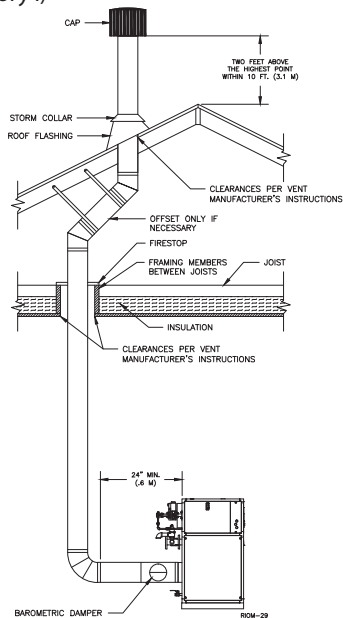

Vent Connections

Locate the boiler/water heater as close to the chimney as possible. Use the shortest, straightest vent connector possible for the installation. If horizontal runs exceed 5 ft, 1.5 m they must be supported at 3 ft, 0.9 m intervals with overhead hangers. Use a single wall stainless steel vent pipe the same diameter as the flue collar to connect the boiler/water heater to a masonry chimney. When using a listed metal chimney system use the appropriate vent connector.

The vent connector should be sloped up toward the chimney at a minimum rate of 1/4 in/ft, 21 mm/m. On masonry chimneys the connector must terminate flush with the inside of the chimney flue, Figures 8 & 9. Fasten each single wall vent connection with at least 3 corrosion resistant sheet metal screws.

Always provide a minimum clearance of 6 in, 152 mm between single wall vent pipe and any combustible materials.

WARNING Failure to maintain minimum clearances between vent connectors and any combustible material can result in a fire causing extensive property damage, severe personal injury or death!

Exit cones are favorable when used to increase the velocity of the flue gas exiting the stack and, may also help, in cold climates, to reduce ice build-up. Exit cone terminations must be supplied by others, installed per manufacturer's instructions, and meet local and federal code.



Figure 7 Vertical Venting with a Metal Chimney System (Category II)

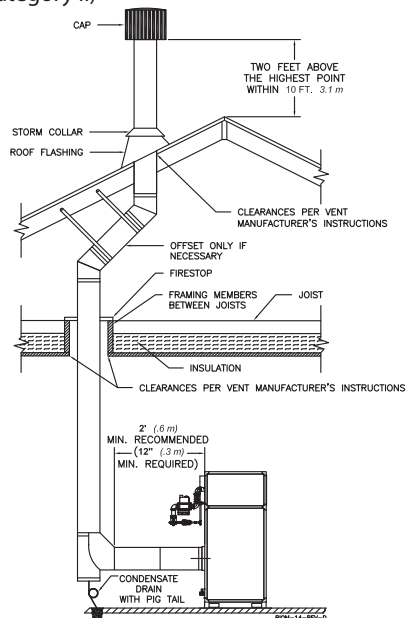

Figure 8 Vertical Venting Using a Lined Masonry Chimney (Category I)

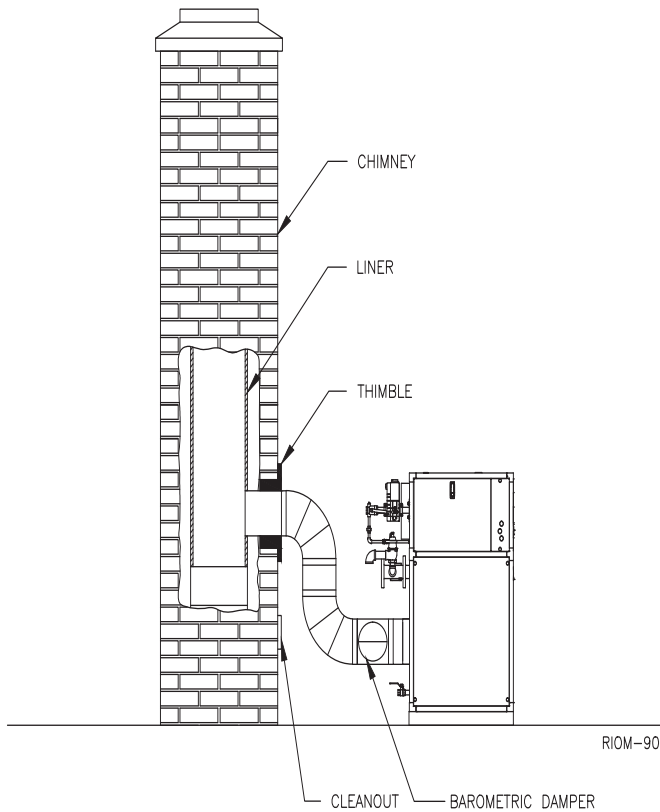

Figure 9 Vertical Venting Using a Lined Masonry Chimney (Category II)

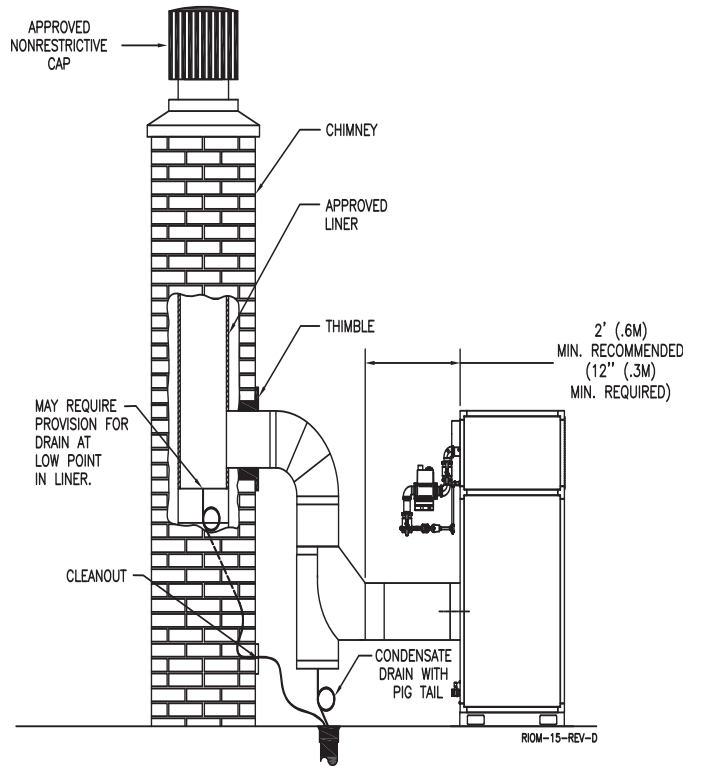

Figure 10 Outdoor Venting (Category IV)

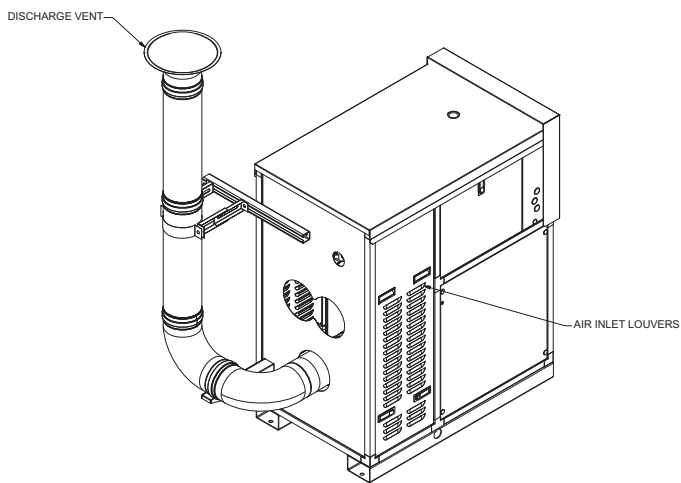
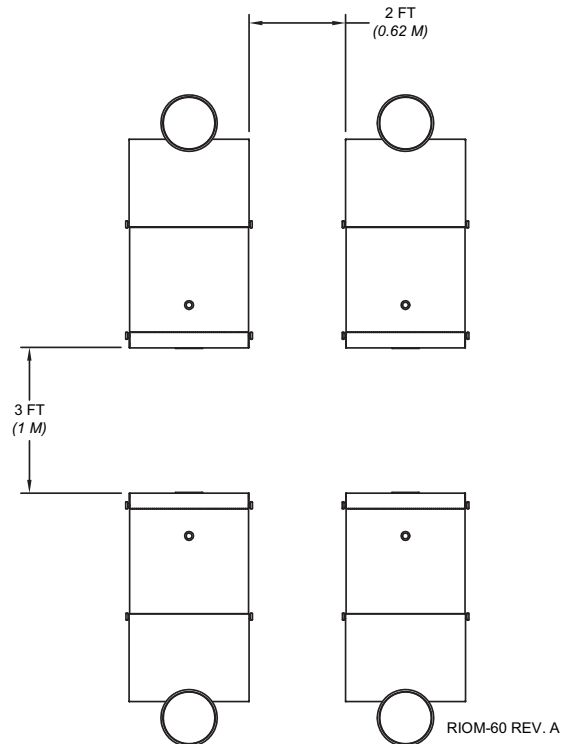

Figure 11 Multiple Outdoor Units



OUTDOOR VENTING

When installed outdoors the Futera III must be fitted with the factory supplied outdoor hood, air intake adapter with filter and exhaust terminal, see Figure 10. Multiple units must be spaced per Figure 11.

The boiler/heater must be at least **2 ft, .62 m** from any door, window or gravity air inlet into any building and at least **3 ft, 1 m** from any overhang unless local codes dictate differently.

Avoid locations where wind deflection off of adjacent walls, buildings or shrubbery might cause a downdraft. The unit(s) should be located at least **3 ft, 1 m** from structures. Outdoor installations are not recommended in areas where the danger of snow blockage exists.

CAUTION Do not place the boiler/water heater in a location that would subject it to runoff from adjacent buildings or damage may occur voiding the warranty!

COMMON VENT SYSTEMS

On multiple boiler common vent applications, the master boiler may be required to be first on and installed closest to the verticle chimney (consult factory).

If an existing boiler/water heater is removed from a common venting system, the common venting system may then be too large for the proper venting of the remaining appliances connected to it. At the time of removal of an existing boiler/water heater, the following steps shall be followed with each appliance remaining connected to the common venting system placed in operation, while the other appliances remaining connected to the common venting system are not in operation.

Au moment du retrait d'une chaudière existante, les mesures suivantes doivent être prises pour chaque appareil toujours raccordé au système d'évacuation commun et qui fonctionne alors que d'autres appareils toujours raccordés au système d'évacuation ne fonctionnent pas: système d'évacuation

- a) Seal any unused openings in the common venting system.
Sceller toutes les ouvertures non utilisées du système d'évacuation.
- b) Visually inspect the venting system for proper size and horizontal pitch and determine there is no blockage or restriction, leakage, corrosion and other deficiencies which could cause an unsafe condition.
Inspecter de façon visuelle le système d'évacuation pour déterminer la grosseur et l'inclinaison horizontale qui conviennent et s'assurer que le système est exempt d'obstruction, d'étranglement de fuite, de corrosion et autres défaillances qui pourraient présenter des risques.
- c) Insofar as is practical, close all building doors and windows and all doors between the space in which the appliances remaining connected to the common venting system are located and other spaces of the building. Turn on clothes dryers and any appliance not connected to the common venting system. Turn on any exhaust fans, such as range hoods and bathroom exhaust, so they will operate at maximum speed. Do not operate a summer exhaust fan for a boiler installation. Close fireplace dampers.

Dans la mesure du possible, fermer toutes les portes et les fenêtres du bâtiment et toutes les portes entre l'espace où les appareils toujours raccordés du système d'évacuation sont installés et les autres espaces du bâtiment. Mettre en marche les sècheuses, tous les appareils non raccordés au système d'évacuation commun et

tous les ventilateurs d'extraction comme les hottes de cuisinière et les ventilateurs des salles de bain.

S'assurer que ces ventilateurs fonctionnent à la vitesse maximale. Ne pas faire fonctionner les ventilateurs d'été. Fermer les registres des cheminées.

- d) Place in operation the appliance being inspected. Follow the lighting instructions. Adjust thermostat so appliance will operate continuously.
Mettre l'appareil inspecté en marche. Suivre les instructions d'allumage. Régler le thermostat de façon que l'appareil fonctionne de façon continue.
- e) Test for spillage at the draft hood relief opening after 5 minutes of main burner operation. Use the flame of a match or candle, or smoke from a cigarette, cigar or pipe.
Faire fonctionner le brûleur principal pendant 5 min ensuite, déterminer si le coupe-tirage déborde à l'ouverture de décharge. Utiliser la flamme d'une allumette ou d'une chandelle ou la fumée d'une cigarette, d'un cigare ou d'une pipe.
- f) After it has been determined that each appliance remaining connected to the common venting system properly vents when tested as outlined above, return doors, windows, exhaust fans, fireplace dampers and any other gas-burning appliance to their previous condition of use.

Une fois qu'il a été déterminé, selon la méthode indiquée ci-dessus, que chaque appareil raccordé au système d'évacuation est mis à l'air libre de façon adéquate. Remettre les portes et les fenêtres, les ventilateurs, les registres de cheminées et les appareils au gaz à leur position originale.

- g) Any improper operation of the common venting system should be corrected so the installation conforms with the National Fuel Gas Code, ANSI Z223.1/NFPA 54. When resizing any portion of the common venting system, the common venting system should be resized to approach the minimum size as determined using the appropriate tables in Appendix F in the National Fuel Gas Code, ANSI Z223.1/NFPA 54 and or CAN/CGA B149 Installation Codes.

Tout mauvais fonctionnement du système d'évacuation commun devrait être corrigé de façon que l'installation soit conforme au National Fuel Gas Code, ANSI Z223.1/NFPA 54 et (ou) aux codes d'installation CAN/CGA-B149. Si la grosseur d'une section du système d'évacuation doit être modifiée, le système devrait être modifié pour respecter les valeurs minimales des tableaux pertinents de l'appendice F du National Fuel Gas Code, ANSI Z223.1/NFPA 54 et (ou) des codes d'installation CAN/CGA-B149.

GENERAL PIPING REQUIREMENTS

CAUTION Improper piping of this boiler/water heater will void the manufacturer's warranty and can cause boiler failure resulting in flooding and extensive property damage! Excessive water hardness causing scaling in the copper heat exchanger tubes is NOT covered under the manufacturer's warranty, see Table 9. Excessive pitting and erosion of the internal surface of the copper heat exchanger tubes is NOT covered under the manufacturer's warranty if the result of high water flow rates, see Table 8. Return water temperatures below **125°F, 52°C** will result in heat exchanger damage from excessive condensation voiding the manufacturer's warranty, see Primary/Secondary Piping, Figure 13.

Figure 12 Futera III Piping

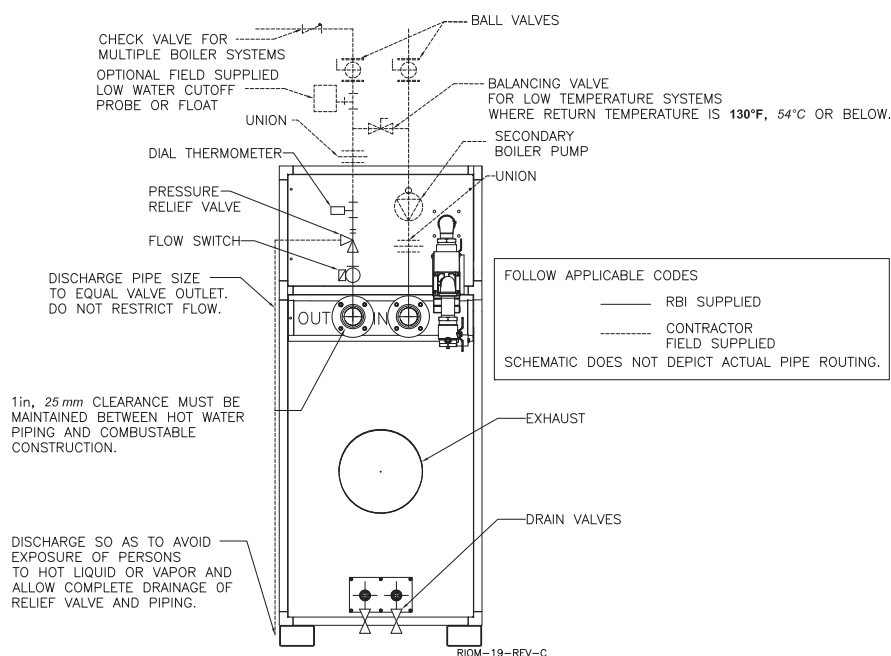

NOTICE Shut off valves and unions should be installed at the inlet and outlet connections of the boiler/hot water heater to provide for isolation of the unit should servicing be necessary.

Freeze Protection

Installations in areas where the danger of freezing exists are not recommended unless proper freeze protection is provided. The following precautions **MUST** be observed:

1. A continuous flow of water through the unit **MUST** be maintained! The pump responsible for flow through the boiler/water heater must run continuously!
2. An ethylene glycol/water mixture suitable for the minimum temperature that the unit will be exposed to must be used. The pump must be capable of producing a minimum of 15% more flow and overcoming a 20% increase in head loss. Domestic water systems must be isolated from the water heater by the use of a heat exchanger or other approved method.
3. If the unit must be shut off for any reason the electric, gas and water supplies **MUST** be shut off and the unit and its pump completely drained.

CAUTION Improper outdoor installation of this unit can cause boiler failure voiding the manufacturer's warranty!

Valve

Pipe the discharge of the pressure relief valve as shown in Figure 12.

WARNING Never install any type of valve between the boiler/water heater and the relief valve or an explosion causing extensive property damage, severe personal injury or death may occur!

Flow Switch

The flow switch supplied with the boiler/water heater must be wired to the terminal strip in the control panel to prevent the boiler from firing unless there's adequate water flow through the unit. The flow switch must be installed in the supply piping adjacent to the boiler outlet connection.

CAUTION Failure to properly install the flow switch may result in damage to the boiler/water heater heat exchanger voiding the warranty!

HEATING SYSTEM PIPING

General Piping Requirements

All heating system piping must be installed by a qualified technician in accordance with the latest revision of the ANSI/ASME Boiler and Pressure Vessel Code, Section IV, and ANSI/ASME CSD-1, Standard for Controls and Safety Devices for Automatically Fired Boilers. All applicable local codes and ordinances must also be followed. A minimum clearance of **1 in, 25 mm** must be maintained between heating system pipes and all combustible construction. All heating system piping must be supported by suitable hangers not the boiler. The thermal expansion of the system must be considered when supporting the system. A minimum system pressure of **12 psig, 82.7 kPa** must be maintained.

Heating Boiler Piping Connections

The supply and return connections should be sized to suit the system, see Table 7.

Table 7 Supply & Return Pipe Sizing (Flanged)

Model Size	Supply Size	Return Size
500 thru 1000	2"	2"
1250 thru 2000	2 1/2"	2 1/2"

Pump Requirements

This low mass boiler requires a continuous minimum water flow for proper operation. The system pump must be sized to overcome the head loss of the boiler and the heating system in order to achieve the required temperature rise. Table 8 provides the heat exchanger pressure drop and temperature rise figures. The temperature rise across the boiler must never exceed **35°F, 19.4°C**. The adjustable pump delay turns the pump on each time the burner fires and runs the pump for 20 to 600 seconds after the call for heat is satisfied.

CAUTION A temperature rise outside of the range listed in Table 8 indicates that the flow rate through the heat exchanger is incorrect which will damage the heat exchanger voiding the warranty! The maximum allowable temperature rise is **35°F, 19.4°C**.

The maximum allowable flow rate through a Futera III boiler is 97 GPM, 6.1 L/s on 500 through 1000 models and 136 GPM, 8.6 L/s for 1250 through 2000 models. The Cupro-Nickel heat exchanger allows for 108 GPM, 6.8 L/s on 500 through 1000 models and 151 GPM, 9.5 L/s on 1250 through 2000 models.

Table 8 Temperature Rise Table

Model Number	$\Delta T = 20^{\circ}\text{F}$		$\Delta T = 11.1^{\circ}\text{C}$	
	Flow Rate GPM	Pres. Drop Ft	Flow Rate L/s	Pres. Drop kPa
500	43.5	0.55	2.7	1.6
750	65.3	1.63	4.1	4.8
1000	87.0	3.59	5.5	10.6
1250	108.8	2.21	6.9	6.5
1500	130.5	3.73	8.2	11.0
Model Number	$\Delta T = 25^{\circ}\text{F}$		$\Delta T = 13.9^{\circ}\text{C}$	
	Flow Rate GPM	Pres. Drop Ft	Flow Rate L/s	Pres. Drop kPa
500	34.8	0.36	2.2	1.1
750	52.2	1.08	3.3	3.2
1000	69.6	2.37	4.4	7.0
1250	87.0	1.46	5.5	4.3
1500	104.4	2.46	6.6	7.3
1750	121.8	3.84	7.7	11.3
2000	139.2	5.63	8.8	16.6
Model Number	$\Delta T = 30^{\circ}\text{F}$		$\Delta T = 16.7^{\circ}\text{C}$	
	Flow Rate GPM	Pres. Drop Ft	Flow Rate L/s	Pres. Drop kPa
750	43.5	0.77	2.7	2.3
1000	58.0	1.69	3.7	5.0
1250	72.5	1.04	4.6	3.1
1500	87.0	1.76	5.5	5.2
1750	101.5	2.74	6.4	8.1
2000	116.0	4.01	7.3	11.8
Model Number	$\Delta T = 35^{\circ}\text{F}$		$\Delta T = 19.4^{\circ}\text{C}$	
	Flow Rate GPM	Pres. Drop Ft	Flow Rate L/s	Pres. Drop kPa
750	37.3	0.58	2.4	1.7
1000	49.7	1.27	3.1	3.8
1250	62.1	0.78	3.9	2.3
1500	74.6	1.32	4.7	3.9
1750	87.0	2.06	5.5	6.1
2000	99.4	2.02	6.3	8.9

Low Water Cutoff

If a boiler is installed above any radiation elements it must be fitted with a low water cutoff device.

Refer to the wiring diagram supplied with the boiler/water heater for proper wiring connections.

Expansion Tank & Air Separator

An expansion tank or other means to control thermal expansion must be installed in the heating system. An expansion tank must be installed close to the boiler on the suction side of the pump. An air scoop and automatic air vent must also be installed to eliminate air trapped in the system.

Primary/Secondary Piping

Boilers connected to heating systems using zone valves, zone pumps, or systems that have excessive flow rates or return water temperatures less than **125°F, 52°C** must be isolated from these systems to protect the boiler.

Variable Water Flows

Figure 13 shows a typical primary/secondary piping system. A dedicated pump is used to maintain a constant water flow through the boiler. This secondary pump is sized to overcome the head loss of the boiler and secondary piping system while supplying the flow rate required to maintain the desired temperature rise across the boiler. The primary pump is sized to provide the required flow to the heating system. The secondary piping connections to the primary system piping must not be more than **12 in, 305 mm** apart to ensure zero pressure drop in the primary system, see Figure 13.

Low Return Water Temperatures

To prevent the problems associated with condensation of the products of combustion due to low return water temperatures a primary/secondary piping system with a bypass configuration must be installed, see Figure 14. The bypass system must be sized the same as the secondary piping. The primary and secondary pumps should be sized to provide the required flow through each system. The secondary piping connections to the primary system piping must not be more than **12 in, 305 mm** apart to ensure zero pressure drop in the primary system, see Figure 14.

Multiple Boiler Systems

Systems using multiple boilers can also be installed using a primary/secondary manifold system, Figure 15.

Piping For Use With Cooling Units

The boiler, when used in connection with a refrigeration system, must be installed so the chilled medium is piped in parallel with the boiler. Appropriate valves must be used to prevent the chilled water from entering the boiler.

When a boiler is connected to a heating coil that may be exposed to refrigerated air from an air handling device, the piping system must be equipped with flow-control valves or some other automatic means of preventing gravity circulation of the boiler water during the cooling cycle.

Figure 13 Typical Primary/Secondary Piping System (See Notes)

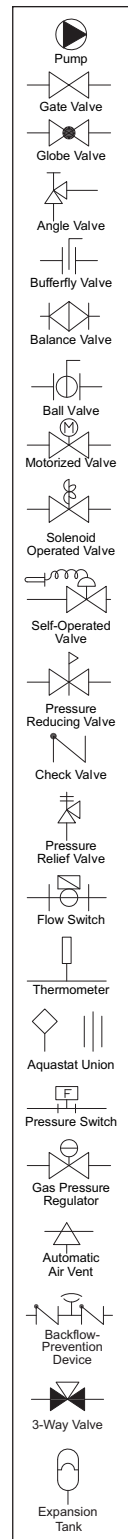
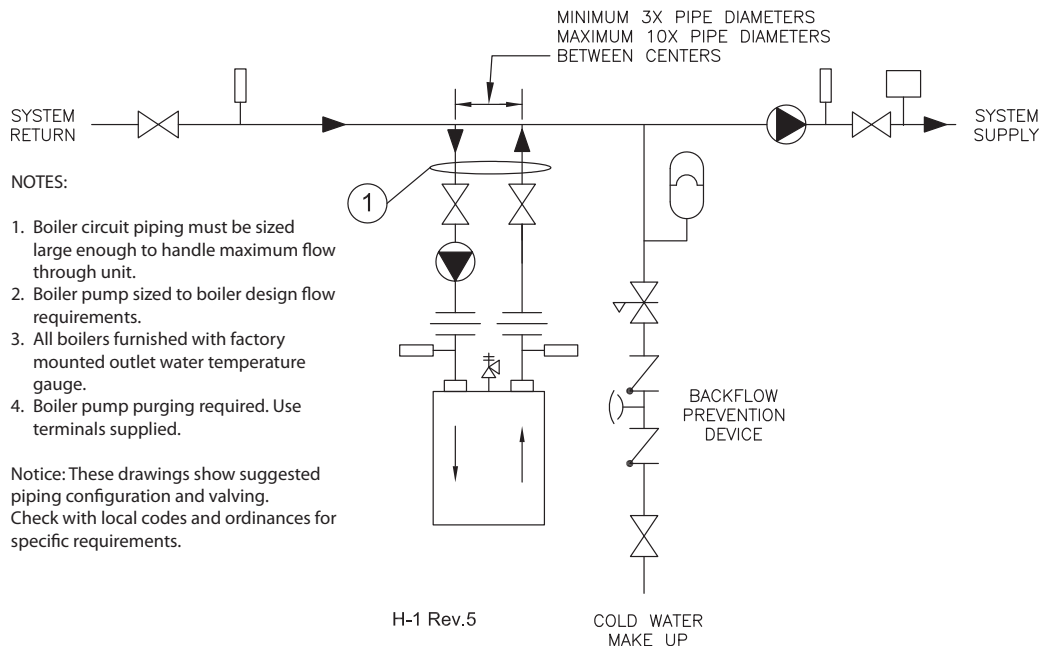
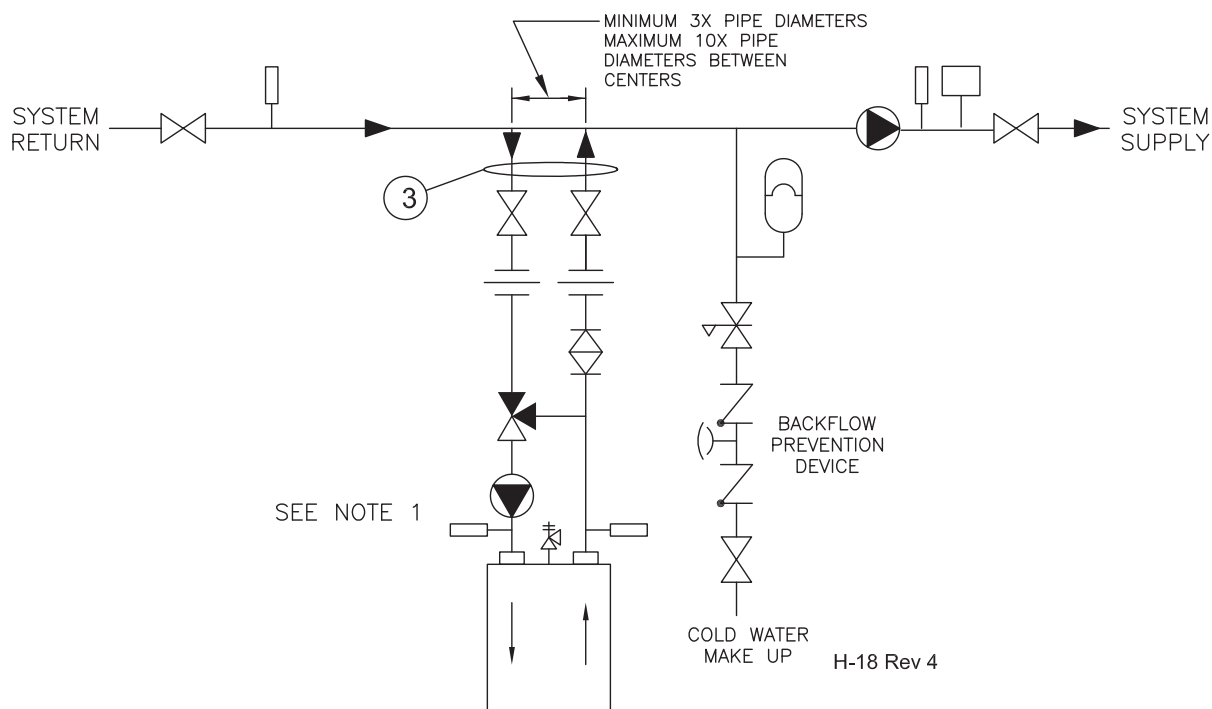

Figure 14 Low Temperature Piping with Thermostatic Valve (See Notes and Adjustment Procedures)



NOTES:

- For pump selection consult factory.
- Boiler pump sized to boiler and thermostatic 3-way valve design flow requirements.
- Boiler circuit piping must be sized large enough to handle maximum flow through unit.
- All boilers furnished with factory mounted outlet water temperature gauge.
- Boiler pump purging required. Use terminals supplied.
- Valve is precalibrated for 140°F return temperature and installed in a mixing configuration.

Notice: These drawings show suggested piping configuration and valving. Check with local codes and ordinances for specific requirements.

Figure 15 Multiple Boiler Piping (See Notes)

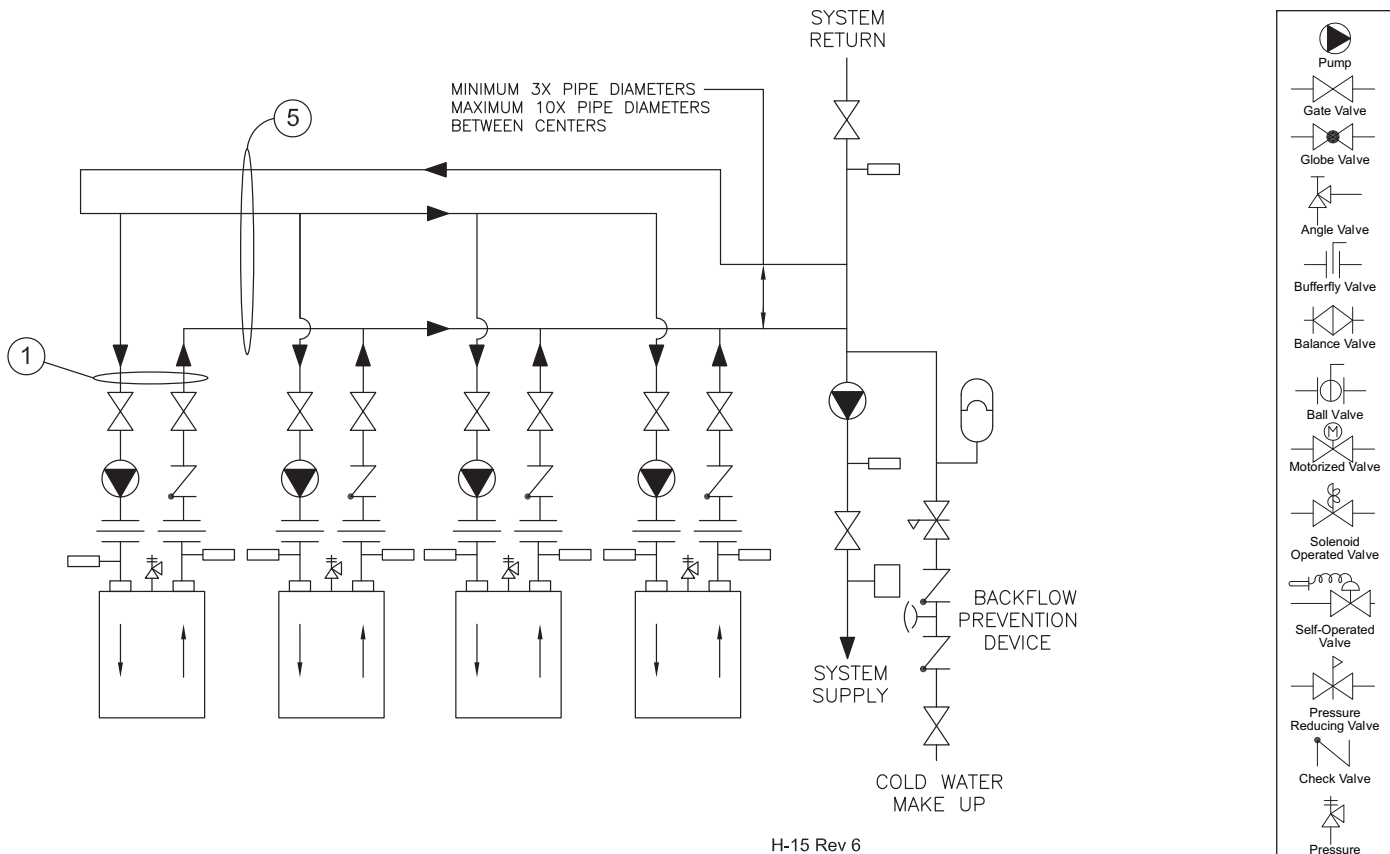

NOTES:

1. Boiler circuit piping must be large enough to handle maximum flow through unit.
2. Boiler pump sized to boiler design flow requirements.
3. All boilers furnished with factory mounted outlet water temperature gauge.
4. Boiler pump purging required. Use terminals supplied.
5. Secondary loop pipe diameter must be sized large enough to handle maximum flow through all units.

Notice: These drawings show suggested piping configuration and valving. Check with local codes and ordinances for specific requirements.

	Pump
	Gate Valve
	Globe Valve
	Angle Valve
	Butterfly Valve
	Balance Valve
	Ball Valve
	Motorized Valve
	Solenoid Operated Valve
	Self-Operated Valve
	Pressure Reducing Valve
	Check Valve
	Pressure Relief Valve
	Flow Switch
	Thermometer
	Aquastat Union
	Pressure Switch
	Gas Pressure Regulator
	Automatic Air Vent
	Backflow-Prevention Device

DOMESTIC WATER SUPPLY PIPING

CAUTION Proper controls must be used to prevent water supplied for domestic use from exceeding **130°F, 54°C** or a scald injury will occur! When higher water temperatures are required for appliances such as a dishwasher, a mixing valve or some other tempering means must be installed. Households with small children may require water temperatures less than **120°F, 49°C**. Local codes must be complied with!

General Piping Requirements

Ensure that the water heater is equipped with bronze headers. Piping and components connected to the water heater must be suitable for use with potable water. The water heater must not be connected to any heating system piping or components previously used with a non-potable water heating appliance. No toxic chemicals, such as those used for boiler treatment, are to be introduced into the potable water used for space heating. If a hot water storage tank is used in the system it must be equipped with a temperature and pressure relief valve that complies with ANSI Z21.22 or CAN-4.4 and CAN-4.6.

NOTICE The storage tank must be located as close to the water heater as possible to prevent excessive head loss which will reduce flow.

Water Chemistry

The required temperature rise across the water heater is based on water having a hardness between 8 and 18 grains per gallon with a level of dissolved solids not exceeding 350 ppm. Water having a hardness less than 8 grains can cause excessive corrosion of the heat exchanger. Water that has a hardness greater than 18 grains per gallon and/or a level of dissolved solids exceeding 350 ppm will require a recalculation of the pump size and temperature rise.

A cupro-nickel heat exchanger may also be required. The manufacturer should be consulted when these water conditions are encountered. See Table 9.

CAUTION The maximum allowable flow rate through a Futera III water heater is 97 GPM, 6.1 L/s on 500 through 1000 models and 136 GPM, 8.9 L/s for 1250 through 2000 models. The cupro-nickel heat exchanger allows for 108 GPM, 6.8 L/s on 500 through 1000 models and 151 GPM, 9.5 L/s on 1250 through 2000 models, see Table 8B.

RBI water heaters are designed to run scale free. Due to the extreme variables of water conditions world wide it is necessary to consider pH values and water hardness in relationship to scaling. It is crucial to consider these two variables when making heat exchanger and pump selections. If local water conditions are extreme, follow the guidelines in the Heat Exchanger Selection (Table 9) and the Pumping Performance (Table 10). Scale free operation can be achieved by using water with a hardness between 8 and 18 and by maintaining the pH between 5 and 9. Follow the conditions listed under NORMAL in the table. In some areas of the country additional precautions must be observed due to unusual characteristics of the local water supply. Call the nearest RBI representative for details.

To properly size the pump a grain hardness and pH test must be taken at the installation site before the order is placed. Proper pump sizing will improve heater performance and help ensure heater longevity.

Expansion Tank

An expansion tank or other means to control thermal expansion must be installed in the water heating system if back flow prevention devices are installed.

Pump Requirements

This low-mass water heater requires a continuous mini-mum water flow for proper operation. The low water flow switch provided for this unit will shut down the water heater if flow falls below the required minimum level. Table 10 provides the heat exchanger pressure drop chart and temperature rise table. **The temperature rise across the water heater must never exceed 35°F, 19.4°C.**

Cold Water Supply

The cold water supply must be piped to the water heater's outlet piping between the water heater and the hot water storage tank. This will prevent untempered water from entering the water heater, see the Temperature Rise Control section below. Two typical water heating systems are shown in Figures 16 & 17.

Temperature Rise Control

Water returned to the water heater inlet must not be less than **125°F, 52°C** or excessive condensation of the products of combustion will damage the water heater voiding the warranty. The method outlined below can be employed to prevent this condition from occurring.

A balancing valve should be installed on the outlet side of the water heater for purposes of adjusting the flow rate through the heat exchanger. Thermometers are installed on both the inlet and outlet of the water heater for determining the temperature rise through the unit.

The proper velocity through the water heater must be maintained in accordance with Table 10 for efficient operation and long life. If the temperature rise through the water heater is lower than recommended the water velocity is too high. Premature erosion of the heat exchanger will occur. Conversely, if the temperature rise is higher than recommended in Table 10 the flow rate is too low. Scaling and softening of the heat exchanger will occur.

Thermostatic Mixing Valve – Water Above 140°F, 60°C Water can be stored at temperatures above **140°F, 60°C** provided that a thermostatically controlled mixing valve is used to temper the hot water to an acceptable temperature before it's supplied for domestic use.

The mixing valve **MUST** be set to prevent a scald injury from occurring, see the caution against scalding.

Storage of water for domestic use above **140°F, 60°C** will provide an increased quantity of tempered water and help prevent the growth of water born bacteria.

Table 9 Futera III Heat Exchanger Selection Graph

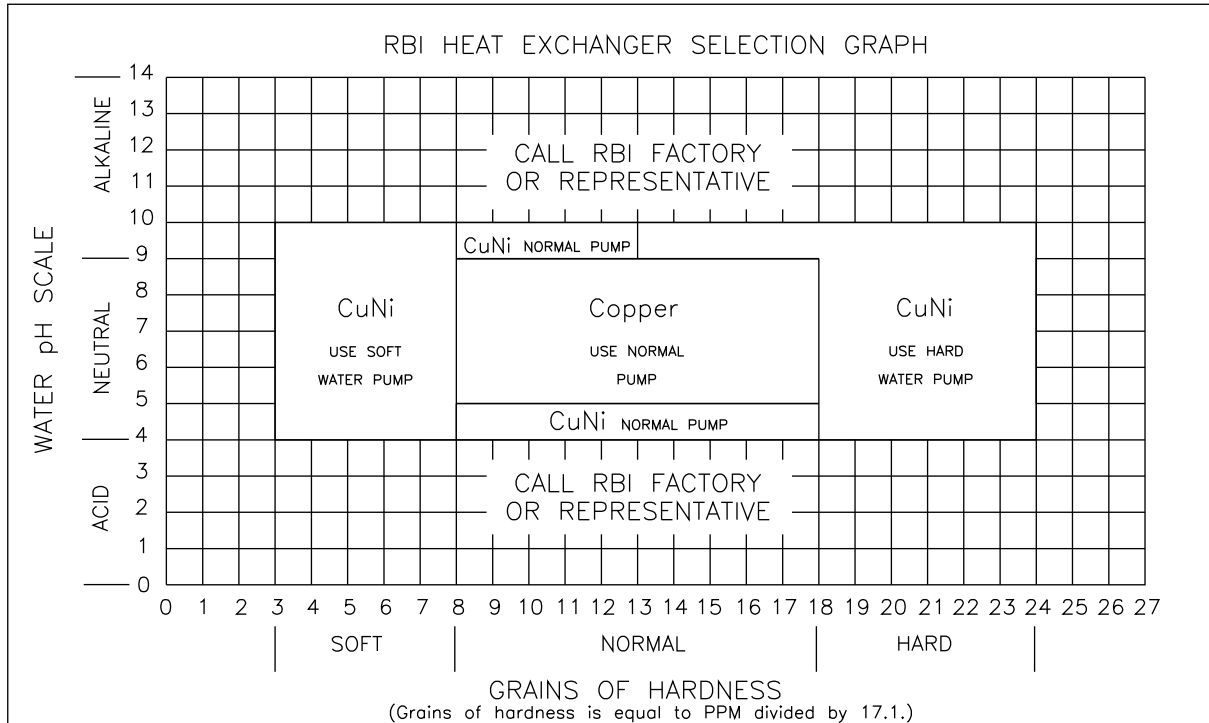

Copyright Pending, MESTEK 12/03

Table 10 Futera III Pumping Performance Requirement

FUTERA III PUMPING PERFORMANCE REQUIREMENTS

WATER HARDNESS HEAT EXCH. TYPE	SOFT			NORMAL			HARD		
	CuNi			Copper			CuNi		
MODEL	GPM	ΔP	ΔT	GPM	ΔP	ΔT	GPM	ΔP	ΔT
MW-500	37	0.42	23.0	75	1.50	11.0	90	2.11	9.0
MW-750	37	0.59	34.0	75	2.11	17.0	90	2.96	14.0
MW-1000	37	0.75	45.0	75	2.72	23.0	90	3.82	19.0
MW-1250	52	0.57	40.0	105	2.07	20.0	131	3.12	16.0
MW-1500	52	0.69	49.0	105	2.49	24.0	131	3.76	19.0
MW-1750	52	0.81	57.0	105	2.91	28.0	131	4.40	23.0
MW-2000	52	0.92	65.0	105	3.33	32.0	131	5.04	26.0

ΔT=Temperature Change=(Outlet Temp.-Inlet Temp.) in F.
 ΔP=Head Loss=(Inlet Pres.-Outlet Pres.) in feet of Water Column.
 To achieve the proper flow rate adjust outlet valve on heater piping to obtain the correct ΔT.
 Call factory if grains of hardness is less that 3 or greater than 24.

SPECIAL REQUIREMENTS
 (CALL FACTORY OR REPRESENTATIVE)

Copyright Pending, MESTEK 12/03

Figure 16 Typical Water Heating Piping (MW Models Only)

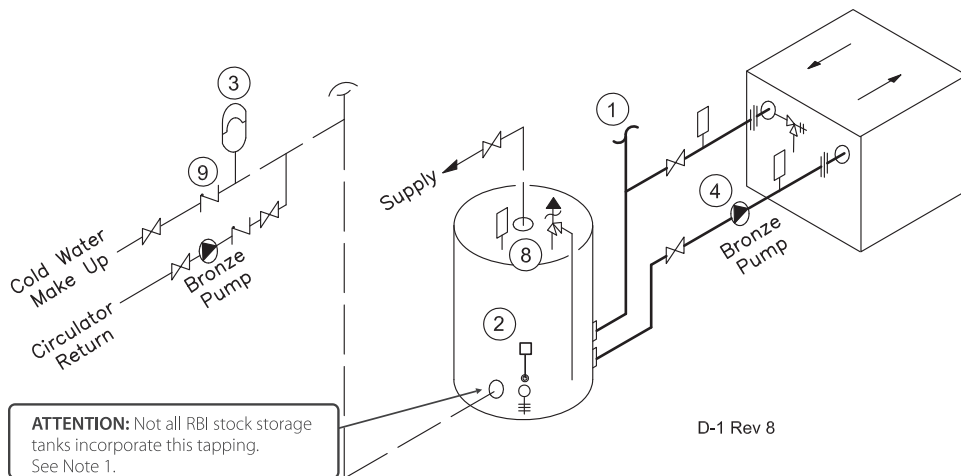

NOTICE These drawings show suggested piping configuration and valving. Check with local codes and ordinances for specific requirements.

Figure 17 Multiple Water Heating Piping (MW Models Only) (See Notes)

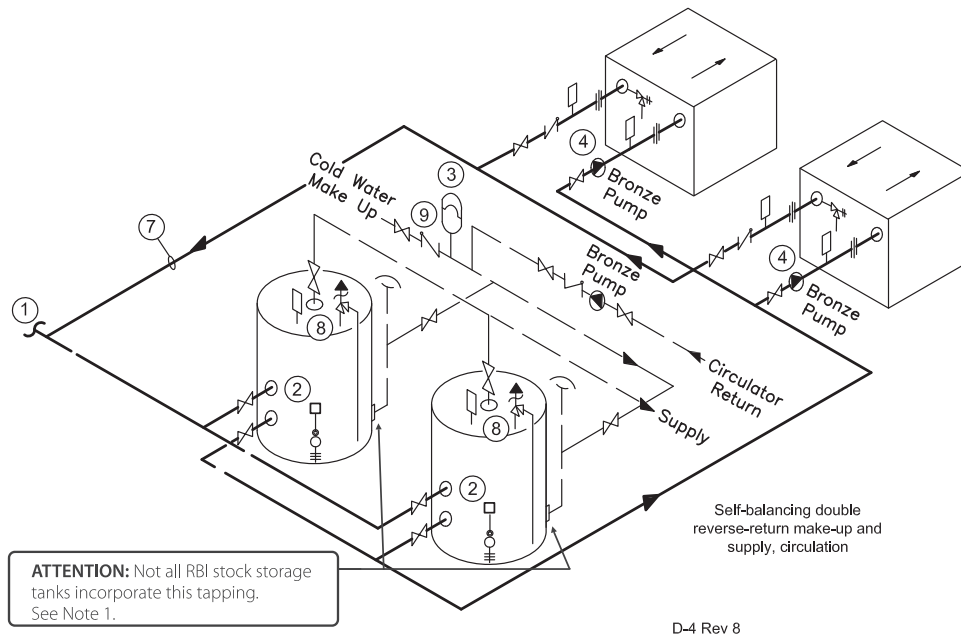

NOTES:

- Optional cold water make up and recirculation line location.
- When using intermittent pump and pump delay, locate remote HeatNet sensor with well in lower 1/3 of tank. Install sensor with heat sensing compound. For multiple tanks, self balancing reverse-return systems, a single HeatNet sensor is applied.
- Thermal expansion tank may be required, check local codes.
- When using optional factory mounted pump, max pipe length 30 ft total, 6-90° elbows, full pipe size.
- CAUTION: MEASURE WATER HARDNESS AND pH AT JOB SITE.**
- The pH and water hardness must be measured before selecting heat exchanger and pump. Consult the Heat Exchanger Graph and Pumping Performance Table before making selection.
- Common piping must be sized for maximum combined heater flow.
- Hot water tanks should be equipped with a combination temperature & pressure relief valve.
- MA Code requires an 1/8 in hole in check valve to compensate for thermal expansion.

Notice: These drawings show suggested piping configuration and valving. Check with local codes and ordinances for specific requirements.

GAS SUPPLY PIPING

WARNING Check the boiler/water heater rating plate to make sure that the boiler/water heater is for the type of gas that will be used. If it isn't, do not connect the boiler/water heater to the gas supply. Gas supply piping must be in accordance with the National Fuel Code, ANSI Z223.1-latest revision or applicable provisions of the local building codes. Canadian installations must comply with CAN/CGA B149.1 or .2 Installation Code. Failure to comply with this warning can result in extensive property damage, severe personal injury or death!

The Futera III comes from the factory ready to be piped to the gas supply. If for any reason the boiler/water heater is not for the type of gas available at the installation site, call your RBI representative to resolve the problem.

NOTICE A minimum gas supply pressure of 2 in, 51mm, W.C. natural or propane and maximum 14 in, 356 mm W.C. natural or propane, must be available at the safety shutoff valve inlet with the unit(s) operating.

Table 11 should be used to ensure that the gas supply piping is sized properly. If more than one appliance is supplied by the same supply pipe, the piping must be sized based on the maximum possible demand. Do not neglect the pressure drop due to pipe fittings. Table 11 should be used in conjunction with Table 12 to ensure that the gas supply piping has the capacity to meet the demand.

Figure 18 depicts the proper way to connect the boiler/water heater to the gas supply piping. The manual shut-off valve **MUST** be installed in the supply piping. It should be installed **5 ft, 1.5 m** above the floor where required by local codes. Provide a sediment trap at the bottom of the vertical section of the gas supply pipe upstream of the gas controls.

Figure 18 Gas Supply Piping

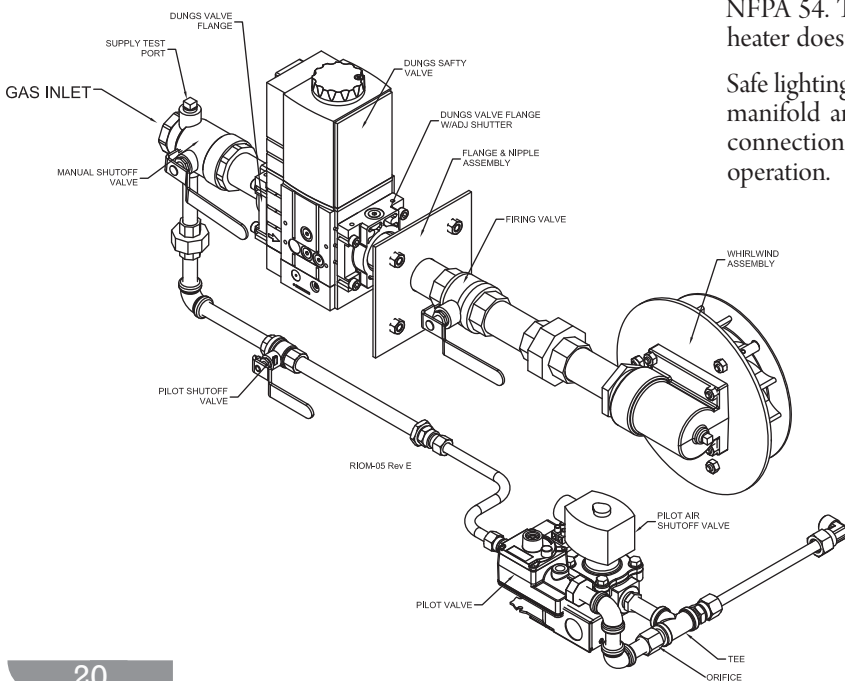

A ground joint union should be installed between the boiler gas controls and the supply piping. Each of these items are needed to ensure long life and ease of servicing. Always use a pipe sealant that is suitable for use with LP gas.

Table 11 Gas Pipe Capacity

Nominal Iron Pipe Size	Pipe length, (ft)								
	10	20	30	40	50	60	80	100	150
	Maximum gas volume of pipe, (ft ³ /hr)								
1"	520	350	285	245	215	195	170	150	120
1 1/4"	1050	730	590	500	440	400	350	305	250
1 1/2"	1600	1100	890	760	670	610	530	460	380
2"	3050	2100	1650	1270	1270	1150	990	870	710

Note: Multiply the gas volume by 0.62 for propane flow capacity in ft³/hr. Multiply the propane flow capacity by 2500 Btu/ft³ to determine the propane Btu/hr capacity for a given pipe size and length.

Table 12 Equivalent Pipe Length Chart

Nominal Iron Pipe Size	Type of pipe fitting			
	90° Elbow	Tee ¹	Gate Valve ²	Gas Cock ²
	Equivalent pipe length, (ft)			
1"	2.6	5.2	0.6	1.5
1 1/4"	3.5	6.9	0.8	1.9
1 1/2"	4.0	8.0	0.9	2.3
2"	5.2	10.3	1.2	3.0

Notes: 1. For flow through branch.
2. For flow at full open.

CAUTION Always use a wrench on the gas valve body when making gas connections to it. Never over-tighten the piping entering the gas valve body or gas valve failure may result!

When applicable, provisions for vent, bleed and gas relief lines must be made in accordance with the latest revision of ANSI Z223.1/NFPA 54. The main Dungs gas valve supplied with boiler/water heater does not require external venting.

Safe lighting and other performance criteria were met with the gas manifold and control assembly provided on the boiler. All gas connections **MUST** be leak tested before putting the boiler into operation.

WARNING Never use an open flame to test for gas leaks. Always use an approved leak detection method. Failure to comply with this warning can cause extensive property damage, severe personal injury or death!

Whenever the gas supply piping is pressure tested the boiler/water heater gas controls must be protected. If the test pressure is equal to, or less than **1/2 psig, 3.5 kPa** isolate the boiler/water heater by closing it's manual shut off valve, see Figure 18. If the test pressure is greater than, or equal to **1/2 psig, 3.5 kPa**, disconnect the boiler/water heater and its individual shut-off valve.

ELECTRICAL WIRING

Electrical Power Connections

CAUTION Label all wires prior to disconnection when servicing controls. Wiring errors can cause improper and dangerous operation! Verify proper operation after servicing.

CAUTION Au moment de l'entretien des commandes, étiquetez tous les fils avant de les débrancher. Des erreurs de câblage peuvent entraîner un fonctionnement inadéquat et dangereux. S'assurer que l'appareil fonctionne adéquatement une fois l'entretien terminé.

The electrical connections to this boiler/water heater must be made in accordance with all applicable local codes and the latest revision of the National Electrical Code, ANSI/NFPA-70. Installation should also conform with CSA C22.1 Canadian Electrical Code Part I if installed in Canada.

Install a separate 120 volt 15 amp or 20 amp circuit breaker for the boiler/water heater and pump, see Table 13. A properly rated shut-off switch should be located at the boiler/water heater. The boiler/water heater must be grounded in accordance with the authority having jurisdiction, or if none, the latest revision of the National Electrical Code, ANSI/NFPA-70.

Table 13 Futera III Electrical Requirements

Futera III Model	Recommended Circuit Breaker (Amps)	*Running Amps
MB/MW 500	15	3.9
MB/MW 750 - 1000	15	6.0
MB/MW 1250 - 2000	20	11.4

*Use separate circuit breaker that is properly sized for pump and pump contactor.

Line voltage field wiring of any controls or other devices must conform to the temperature limitation of type TEW wire at **95°F, 35°C** above room temperature. Use copper conductors with a minimum size of #14 awg. Use appropriate wiring materials for units installed outdoors. The wire size must be compatible with the total amp draw of the circuit.

Refer to the wiring diagram supplied with the boiler/water heater for proper wiring connections and boiler full load amperage (FLA).

GENERAL OPERATION

WARNING Before proceeding read and fully understand the instructions contained in this manual. Do not attempt to operate this boiler/water heater if it has not been installed in accordance with the guidelines set forth in this manual. Failure to comply with this warning can result in extensive property damage, severe personal injury or death!

Should overheating occur or the gas supply fail to shut off, turn off the manual gas control valve to the appliance. Do not interrupt water flow through the boiler/water heater.

En cas de surchauffe ou si l'alimentation en gaz ne s'arrête pas, fermez manuellement le robinet d'arrêt de l'admission de gaz.

Hydronic Heating Boilers

Open the make-up water valve and slowly fill the boiler and all of the radiation with water. Ensure that all bleed and drain valves are closed.

Adjust the make-up water pressure regulator so a minimum **12 psig, 82.7 kPa** system pressure is maintained at the highest point in the system piping. If a make-up water pump is used adjust it to maintain a minimum **12 psig, 82.7 kPa** system pressure.

Open the system bleed and drain valves, one at a time, to purge the air trapped in the heating system piping.

With the boiler off, run the system pump for at least 30 minutes and bleed the system piping using the bleed valves. If strainers are used in the system piping, the make-up water valve should be closed and the strainers checked and cleaned.

The system expansion tank should be checked to ensure that the correct water level in the tank is maintained. The tank should be less than half full of water with the system full and adjusted to the correct operating pressure.

Start the boiler as described in the "OPERATING INSTRUCTIONS" section. Run the boiler for at least an hour. The system pump(s) and all radiation units must be operated during this time. Ensure that the make-up water valve is open.

Shut the boiler off and open the bleed valves to purge the air trapped in the heating system piping. Close the make-up water valve and check and clean the strainers and make-up water pressure reducing valve.

Open the make-up water valve and adjust the system pressure if necessary. The system should be checked and bled after three days of operation.

OPERATING INSTRUCTIONS

FOR YOUR SAFETY READ BEFORE OPERATING.

POUR VOTRE SÉCURITÉ LISEZ AVANT DE METTRE EN MARCHÉ

- A. This appliance is equipped with an ignition device which automatically lights the pilot. Do not try to light the pilot by hand.

Cet appareil est muni d'un dispositif d'allumage qui allume automatiquement la veilleuse. Ne tentez pas d'allumer la veilleuse manuellement.

- B. BEFORE OPERATING smell all around the appliance area for gas. Be sure to smell next to the floor because some gas is heavier than air and will settle on the floor.

WARNING Propane gas may not always be detected by smell. Propane gas is heavier than air and can collect in low areas.

Propane gas can ignite or explode if an ignition source is present and result in death, serious injury and property damage!

FOR YOUR SAFETY

- Have only qualified licensed professionals install, service and maintain this appliance and your gas system in accordance with all applicable codes.
- If you suspect a leak:
 1. Have everyone leave the building immediately.
 2. Do not attempt to light any appliance.
 3. Do not touch any electrical or electronic switches in the building.
 4. Do not use any phone in the building.
 5. Call your gas supplier from a phone outside of the building.
 6. If you cannot reach your gas supplier call the fire department.

AVANT DE FAIRE FONCTIONNER, reniflez tout autour de l'appareil pour déceler une odeur de gaz. Reniflez près du plancher, car certains gaz sont plus lourds que l'air et peuvent s'accumuler au niveau du sol.

QUE FAIRE SI VOUS SENTEZ UNE ODEUR DE GAZ:

- Ne pas tenter d'allumer d'appareil.
- Ne touchez à aucun interrupteur; ne pas vous servir des téléphones se trouvant dans le bâtiment.
- Appelez immédiatement votre fournisseur de gaz depuis un voisin. Suivez les instructions du fournisseur.
- Si vous ne pouvez rejoindre le fournisseur, appelez le service de incendies.

- C. Do not use this appliance if any part has been under water. Immediately call a qualified service technician to inspect the appliance and to replace any part of the control system and any gas control that has been under water.

N'utilisez pas cet appareil s'il a été plongé dans l'eau, même partiellement. Faites inspecter l'appareil par un technicien qualifié et remplacez toute partie du système de contrôle et toute commande qui ont été plongés dans l'eau.

Operating Instructions

1. **STOP!** Read the safety information above. If, at any time, the appliance will not operate properly, follow the instructions "TO TURN OFF GAS TO APPLIANCE" and call your service technician or gas supplier.
2. Set the operating control to off and disable any outside (BMS) call for heat.
3. Turn off all electric power to the appliance.
4. Close main isolation gas valve (field supplied), Figure 18.
5. Purge the gas piping up to the manual valve ahead of the main gas control of air. When the bleeding is complete, check all gas joints up to the gas valve for leaks.
6. Wait five (5) minutes to clear out any gas.
7. Install a fitting at the supply test port and connect a manometer having a minimum range of **20 in, 508 mm WC** to it, Figure 18.
8. Remove the 1/8" pipe plug from the pilot test port located on the CV100 pilot/reg combination gas valve and connect a manometer having a minimum range of **6 in, 154 mm WC** to it, Figure 20.
9. Open the main isolation gas valve (field supplied), Figure 18.
10. Place the "Remote/Local" switch to Remote inside control cabinet, Figure 19.
11. Turn the power switch on the front of the boiler to "on". It will light up when the power is on. If all interlocks are properly closed, the display will say "Standby", Figure 19.
12. Slide the Low Fire Hold Switch (on HeatNet control board) to Low Fire position.
13. The boiler will begin the start sequence.
14. When the main display reads "PILOT RUNNING" and the flame current is 5 VDC, switch the Honeywell 7800 to the "test" position, Figure 19. This will hold the Honeywell 7800 in its ignition state.
15. Adjust the pilot pressure per the CHECKING, ADJUSTMENT & OPERATION section.
16. Remove the demand from the 7800 control by disabling the Low Fire switch allowing the boiler to stop.

Figure 19 HeatNet Control Panel

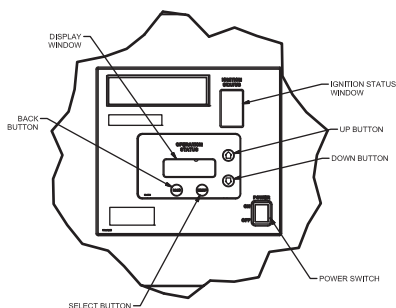
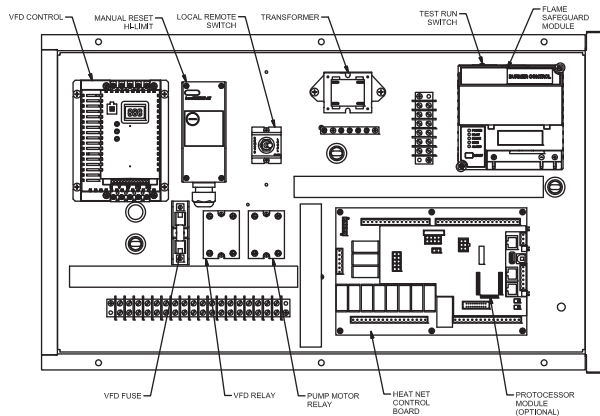

17. Close main isolation gas valve (field supplied), Figure 18.
18. Remove the manometer fitting from the pilot test port and replace the plug. Place monitor tube on to the test port tee located along the 1/3" hose piped directly off of the manifold test port, Figure 20.
19. Switch the Honeywell 7800 back to "run".
20. Create a min input demand as before (enable Low Fire Hold switch.) The boiler will begin the start sequence.
21. Monitor the flame current on the 7800. No flame current should be detected and the 7800 should lock out. If flame current is detected at any time up to the 7800 locking out, the 120V wiring on the ignition transformer must be reversed and the test run again to insure that no flame is detected.

WARNING Improper wiring of the ignition transformer can result in an explosion causing extensive property damage, severe personal injury or death!

22. Open main isolation gas valve (field supplied).
23. Reset the Honeywell 7800. The boiler will start and will run at minimum input rate.

24. **Setting the low fire:** Allow the low fire to settle out for a few minutes and observe the combustion reading. Refer to "Combustion Reading" table for proper combustion readings and elbow pressure, Table 15.

The low fire O₂-CO₂ can be adjusted in the field by opening the low fire adjustment door located on the forward facing side of the main gas valve, see Figure 20. Inserting an allen wrench and rotating the allen screw clock-wise will increase the CO₂ and lower the O₂, rotating counter clock-wise will decrease the CO₂ and increase the O₂. **DO NOT LEAVE THE BURNER IN AN INFRARED STATE.** A few random speckles of red are fine, but large concentrations of spots or large areas of red are not. If large amounts of red concentrations are observed, verify combustion readings.

25. Jumper the "AA" terminals located on the HeatNet control board. The boiler input will rise to its maximum input, "Run 100%", see Figure 22.
26. Allow the boiler to reach steady state and verify supply gas pressure and check input rates as explained in the "Gas Supply Piping" section. Also, refer to "Combustion Reading" table for proper combustion readings and elbow pressure, Table 15. The high five trim is located on the outlet flange of the gas valve, see Figure 20. O₂-CO₂ can be adjusted by inserting a screw driver and rotating clockwise to increase the CO₂ and lower the O₂. Rotating counterclockwise will decrease the CO₂ and increase the O₂.
27. Remove jumper "AA" and allow boiler to settle into minimum input. Observe the combustion readings and make any final adjustments. When finished disable the Low Fire Hold Switch and replace test ports to normal state.
28. Boiler allows for many modes of operation and control methods. Reference the "HeatNet Control Manual".

Table 14 Combustion Readings (Category I)

	Natural Fuel	Propane Fuel
CO ₂ %	7.6 - 7.8 (min.)	8.8 - 9.0 (min.)
	7.8 - 8.0 (100%)	9.0 - 9.4 (100%)
O ₂ %	7.5 - 7.0 (min.)	7.5 - 7.0 (min.)
	7.0 - 6.7 (100%)	7.0 - 6.7 (100%)

For factory set gas manifold (elbow) pressures see label on inner cabinet door.

Table 15 Combustion Readings (Category II and IV)

	Natural Fuel	Propane Fuel
CO ₂ %	8.0 - 8.5 (min.)	9.4 - 9.9 (min.)
	8.8 - 9.8 (100%)	10.3 - 11.5 (100%)
O ₂ %	6.6 - 5.8 (min.)	6.6 - 5.8 (min.)
	5.2 - 3.5 (100%)	5.2 - 3.5 (100%)

For factory set gas manifold (elbow) pressures see label on inner cabinet door.

Figure 20

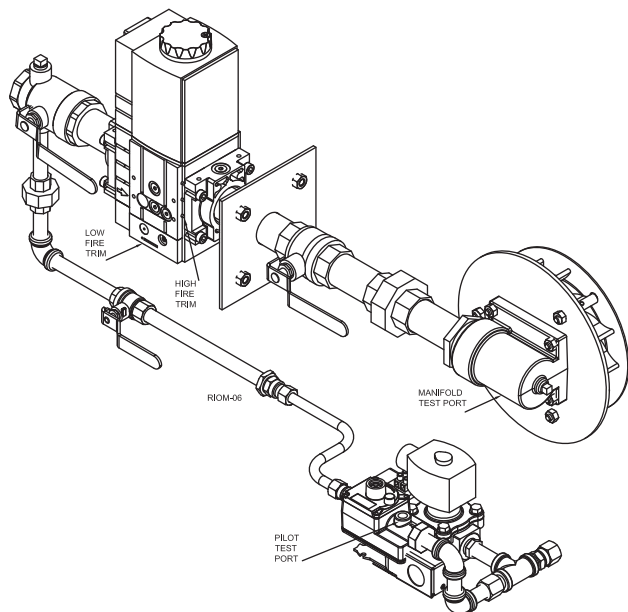

INSTRUCTIONS DE MISE EN MARCHÉ

1. ARRÊTEZ! Lisez les instructions de sécurité sur la portion supérieure de cette étiquette.
2. Réglez le thermostat à la température la plus basse.
3. Coupez l'alimentation électrique de l'appareil.
4. Cet appareil est muni d'un dispositif d'allumage qui allume automatiquement la veilleuse. Ne tentez pas d'allumer la veilleuse manuellement.
5. Fermer la vanne manuelle d'arrêt d'alimentation de gaz.
6. Attendre cinq (5) minutes pour laisser échapper tout le gaz. Reniflez tout autour de l'appareil, y compris près du plancher, pour déceler une odeur de gaz. Si vous sentez une odeur de gaz, ARRÊTEZ! Passez à l'étape B des instructions de sécurité sur la portion supérieure de cette étiquette. S'il n'y a pas d'odeur de gaz, passez à l'étape suivante.
7. Ouvrir la vanne manuelle d'arrêt d'alimentation de gaz.
8. Mettez l'appareil sous tension.
9. Réglez le thermostat à la température désirée.
10. Si l'appareil ne se met pas en marche, suivez les instructions intitulées couper l'admission de gaz de l'appareil et appelez un technicien qualifié ou le fournisseur de gaz.

TO TURN OFF GAS TO APPLIANCE

1. Set the operating control to its lowest setting.
2. Turn off all electric power to the boiler if service is to be performed.
3. Close the manual main and pilot gas shut-off valves.

COMMENT COUPER L'ADMISSION DE GAZ DE L'APAREIL

1. Réglez le thermostat à la température la plus basse.
2. Coupez l'alimentation électrique de l'appareil s'il faut procéder à l'entretien.
3. Fermer la vanne manuelle d'arrêt d'alimentation de gaz.

SEQUENCE OF OPERATION

NO DEMAND

Standby

1. The boiler is idle with no interlocks in the fault condition.

DEMAND

Pre-Purge

1. The blower operates at purge RPM. The water flow interlock must 'make' within 15 seconds after the demand signal is initiated.
2. The Honeywell 7800 starts a 10 second purge delay once the air prove switch contacts close.

Pilot Run - % Input

1. The blower operates at minimum ignition setting. See the calibration section in the "HeatNet Control-IOM" to enter the calibration menus.
2. The ignition transformer is energized. The pilot solenoid valve opens for the 10 second pilot ignition trial.

Main Run % Input

1. The main gas valve opens.
2. The ignition transformer is de-energized.
3. The pilot solenoid valve closes.
4. The blower stays at the minimum input setting for 3 seconds then operates at demand % input. See the calibration section in the "HeatNet Control-IOM" to enter the calibration menus.

NO DEMAND

Post-Purge

1. The main gas valve closes.
2. The blower operates at purge RPM for 10 seconds.
3. The boiler is idle with no interlocks in the fault condition.

CHECKING & ADJUSTMENTS

Spark Gap

With the main and pilot gas manual valves in the closed position energize the unit. Observe the trial for ignition to confirm that the spark is strong and continuous. If not check and adjust the spark gap as shown in Figure 21.

Figure 21 Spark Gap

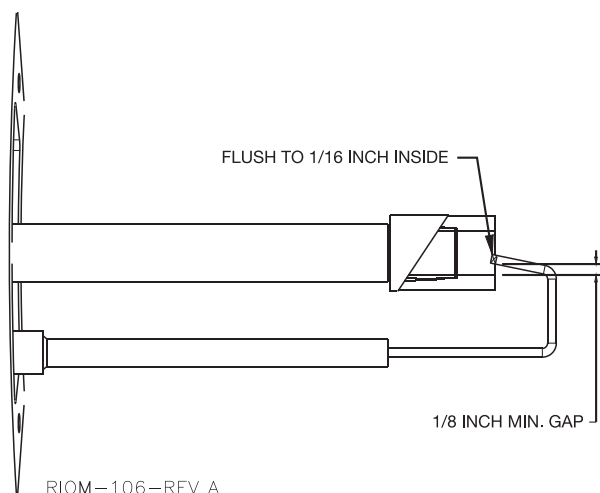

RIOM-106-REV A

Pilot Adjustment

The pilot pressure has been factory set at 3 in. W.C. for natural and LP gas and shouldn't need adjustment. To check the pilot pressure close the manual main shut-off valve 2 and the pilot gas shut-off valve, Figure 18. Remove the 1/8" pipe plug from the pilot tee and connect a manometer having a minimum range of **6 in, 152 mm** WC to it. Open the pilot gas shut-off valve. With the unit powered, generate a call for heat. When the prepurge is complete the ignition/pilot trial will begin. At this point put the Honeywell RM7800 test switch in the test position. The control will hold in the ignition/pilot sequence allowing you to check the pressure.

To adjust the pilot the following steps must be taken:

1. Remove the pilot gas pressure regulator cap.
2. Turn the pressure regulator adjustment screw clock-wise to increase the pressure and counterclockwise to decrease it.
3. Replace the pressure regulator adjustment screw cap.

CAUTION Never force the regulator adjustment screw beyond the stop limits or damage to the regulator will occur!

Required Gas Pressure

Provide gas supply pressure at inlet to boiler gas train as follows:

	LP	Nat
Minimum (in. W.C.)	2	2
Maximum (in. W.C.)	14	14

Measure pressure when the boiler is firing at full rate. Low gas pressure could indicate undersized gas line or insufficient gas supply.

"Static and operating gas pressure required at the gas valve inlet is between 2" W.C. and 14" W.C. for natural gas and 2" W.C. and 14" W.C. propane. If the gas pressure is above this limit, a lock-up style regulator suitable for dead end service such as an Equimeter or Fisher must be installed to prevent increase (creep) of gas pressure when the units are not operating. This pressure regulator (supplied by others) may be installed at the service entrance to each unit or a "master" regulator sized to handle multiple units may be utilized. Consult local gas utility or regulator manufacturer for recommendations to meet specific job site requirements."

Input Rate, Natural Gas

Gas appliances are rated based on sea level operation with no adjustment required at elevations up to **2000 ft, 610 m**. At elevations above **2000 ft, 610 m** input ratings should be reduced by 4% for each **1000 ft, 305 m**.

Check the input rate as follows:

1. Turn off all other gas appliances that use the same gas meter as the boiler/water heater.
2. Call your gas supplier and ask for the heating value of the gas.
3. Start the boiler/water heater and let it run for 15 minutes.
4. Using the gas meter and a stopwatch, clock the time that it takes to burn **10 ft³, 0.28 m³** of gas and divide this time by 10.
5. Insert the heating value and the time, in seconds, into the formula below.
6.
$$\text{Input} = (\text{heating value, Btu/hr})(3600)/(\text{time, seconds})$$
7. If the computed rate deviates by more than 5% from the rated input value of the unit, consult factory.

CAUTION Never increase the input to the boiler/water heater above that for which it is rated. Doing so can cause premature failure of the boiler!

RBI FIELD WIRING TO HEATNET BOARD

Figure 22 RBI Field Wiring to HeatNet Board (Board Revision 3.0 and greater)

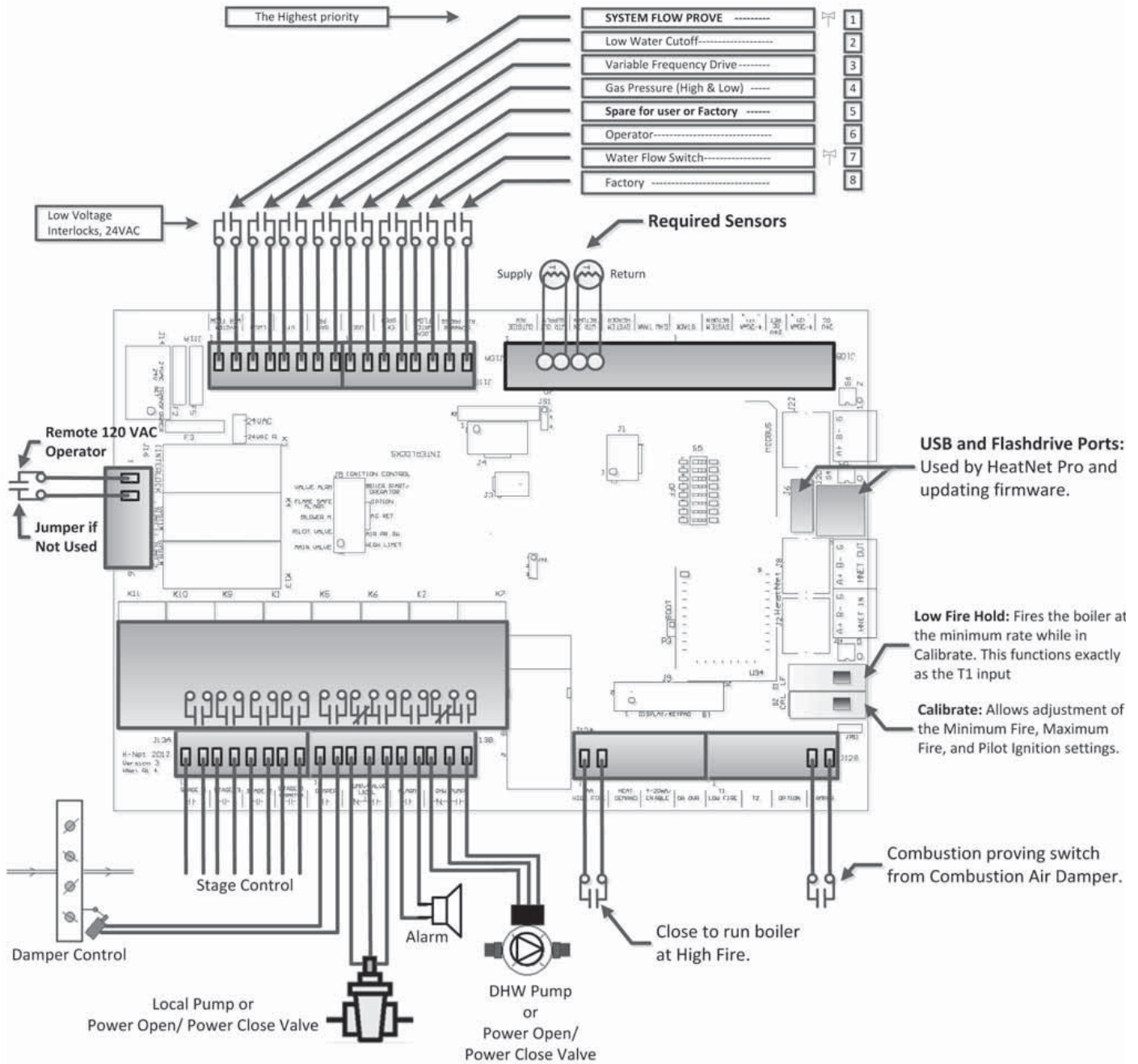

RBI HEATNET FIELD WIRING TO TERMINAL BLOCK

Figure 23

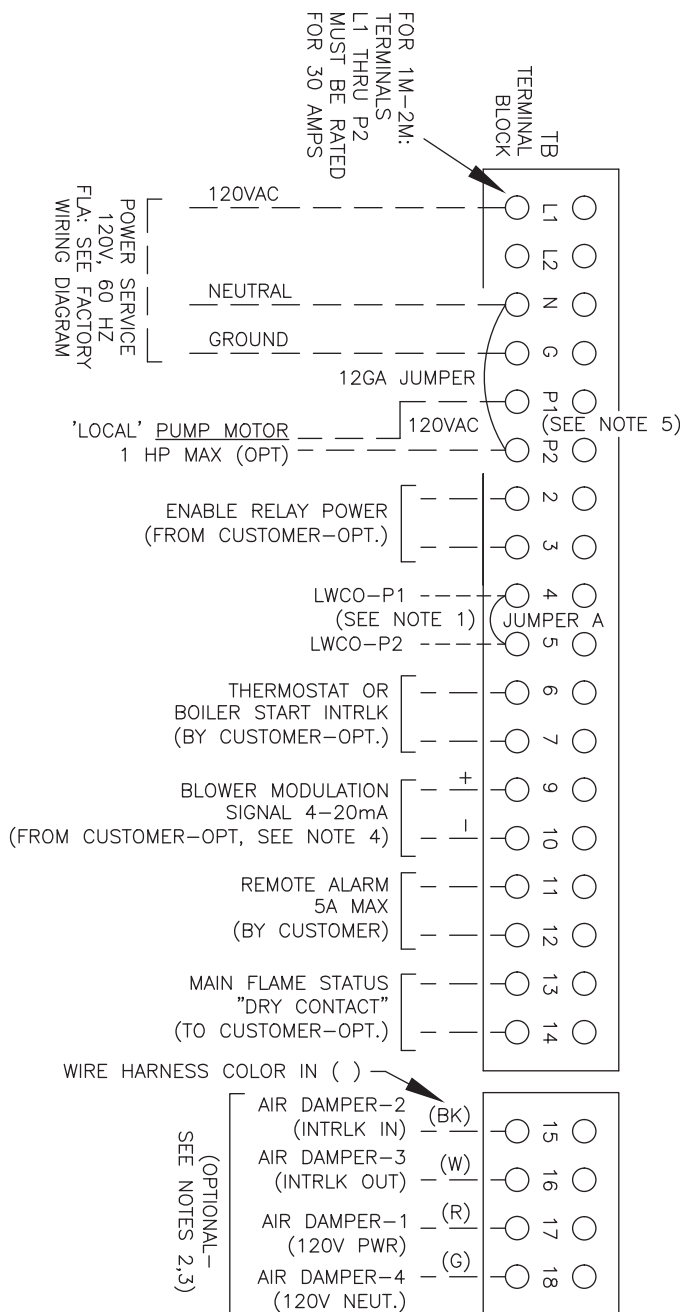

NOTES:

1. Remove jumper "A" when using a low water cutoff interlock.
2. For multiple boilers utilizing a system air damper when in a master/member configuration consult factory or reference wiring diagram 42-0501 sheet 3 for wiring connections.
3. For single boilers or multiple boilers with individual dampers connect the end proving switch to main terminal block 15 and 16. Terminals 17 and 18 provide 120V power to the damper motor.
4. There are two methods in which a 4-20mA signal can be used to control HeatNet equipped boilers.

Method 1

A 4-20mA signal can be used to directly modulate each boiler from a remote panel or building management system. On multiple boiler installations, there is no communication between boilers, no HeatNet system sensor; therefore no master/member relationship exists. (Use Menu: Setup: Setpoints: Setpoint Source: Auto)

Method 2

A 4-20mA signal can be used to change the setpoint temperature the HeatNet is maintaining. This can be used on single or multiple boilers with a master/member relationship. (Use Menu: Setup: Setpoints: Setpoint Source: 4-20, then set the parameters for the temperature and boiler start point.)

5. The 'local' pump relay in the control panel is rated for 1 hp, 1Ø motors. For larger or 3Ø reference factory wiring diagram.

CONTROL DESCRIPTION

Low Water Cutoff

If the boiler is to be installed above radiation or if required by other codes or regulations, install a low water cutoff in appropriate piping. Wire the switch to the “Interlock” contacts as illustrated on “Field Wiring” schematic. Ensure that the low water cutoff device(s) will function properly.

Operating Control

The preferred control setting for potable hot water is **130°F, 54°C**. The operating control should be set to the lowest setting that will satisfy the consumer’s needs.

WARNING Setting the thermostat or operation control too high can result in scalding resulting in severe personal injury!

High Limit (Aquastat)

The high limit is located in the top control area of the boiler/water heater. A remote capillary bulb is run to a well on the outlet side of the supply header. The high limit can be reset by depressing the red button.

The water heater high limit should be set a minimum of **20°F, 11°C** higher than the operating control. Refer to the HOT WATER SUPPLY section for the proper supply water temperature.

Flow Switch

A flow switch is provided in the water outlet piping to prevent the boiler/water heater from firing without adequate water flow through the heat exchanger.

DIAGNOSTICS

The Futera III has a display that indicates the sequence of operation. The display will also list faults should the unit fail to operate. An explanation of each status message and fault can be located in HeatNet Control Manual under status screen fault display section.

STATUS SCREEN FAULT DISPLAY

There are numerous interlock switches and software limits that are detected. Each of these, when tripped will produce a display message, an audible beeping, and an alarm relay closure. The fault is displayed first, then after a second, the time the fault occurred is displayed. This cycle will keep occurring until the fault is cleared. These faults are:

HIGH LIMIT: When the high limit aquastat trips the following message is displayed:

FAULT HIGH LIMIT	SYSTEM SET 160°F
---------------------	-------------------------

FAULT 10/27 9:16	SYSTEM SET 160°F
---------------------	-------------------------

The high limit interlock breaks power to the ignition control (shutting it off) and effectively removes any chance of the gas valve receiving power. The FIII series control will remain powered to display the fault, latch the alarm relay/audible beeper, and to access the log. The interlock is located on J5, HIGH LIMIT.

INTERLOCK SPARE 3: This is a reserved interlock input that is normally jumpered at the factory, but can have a remote interlock connected as a field install. The interlock is located on J11A, SPARE 3.

FAULT INTERLOCK SPARE 3	SYSTEM SET 160°F
----------------------------	-------------------------

LOW WATER CUTOFF: If there is a low water condition reported by the low water cutoff switch this fault is displayed. Check that there is water flow and water in the boiler. There is a reset switch located on the LWCO box. The interlock connection is located on J11A, LWCO.

FAULT LOW WATER CUTOFF	SYSTEM SET 160°F
---------------------------	-------------------------

VAR FREQ DRIVE: The variable frequency drive, which controls the blower, reports this fault in the event of over current or other conditions that would cause it to shut down. If this is the case, check the fault indicators on the VFD. The interlock is located on J11A, VFD.

FAULT VAR FREQ DRIVE	SYSTEM SET 160°F
-------------------------	---------------------

GAS PRESSURE: The optional gas pressure switches (high pressure and low pressure) are connected in series, so if either trip, a fault will be reported here. A reset switch is located on the gas pressure switches. The interlock is located on J11A, GAS PR.

FAULT GAS PRESSURE	SYSTEM SET 160°F
-----------------------	---------------------

INTERLOCK SPARE 4: This is also a spare interlock (similar to INTERLOCK SPARE 3) for future expansion or use as a field interlock. The interlock is located on J11B, SPARE 4.

FAULT INTERLOCK SPARE 4	SYSTEM SET 160°F
----------------------------	---------------------

FLOW SWITCH ERROR: Once the FIII series boiler receives a call for heat, it closes the circulator pump relay. It then waits 10 seconds to prove flow. If there is no flow, the flow switch alarm will be set. Every 10 seconds the circulator pump relay will cycle ON for 10 seconds and then OFF for 10 seconds to try and establish flow. The interlock connection is located on J11B, WTR FLW.

FAULT WATER FLOW SWITCH	SYSTEM SET 160°F
----------------------------	---------------------

IGNITION CTRL ALARM: The ignition control alarm is displayed if the ignition control detects a fault. This could be a flame failure, air proving switch, or other fault associated with the ignition control. When this fault occurs, you will need to refer to the ignition control for the reason.

FAULT IGNITION CTRL ALARM	SYSTEM SET 160°F
------------------------------	---------------------

IRI ALARM: The optional IRI alarm is the alarm from the gas valve. If this alarm is set check the gas valve.

FAULT IRI ALARM	SYSTEM SET 160°F
--------------------	---------------------

COMBUST AIR DAMPER: If the combustion air damper has been selected for use (MASTER BOILER, AUX FUNCTIONS), and the proof switch does not make, this fault will be displayed.

When the combustion air damper is used, the master's BOILER3/DAMPER relay contacts at J13 are closed. These should be wired to the combustion air damper or preferably an isolation relay. The prove switch on the combustion air damper must be wired to J10B, SPARE 1.

FAULT	SYSTEM SET
COMBUSTION AIR DAMPER	160°F

When the master boiler receives a call for heat and needs to start a boiler, the BOILER3/DAMPER relay K5 closes. At the same time, the boiler is started, fires, and continues to fire. If the combustion air damper does not prove within the proof time specified in the combustion air damper menu, the boiler will shut down and display the fault. The fault on the Master boiler can be cleared by removing the call for heat on the master boiler and fixing the combustion air damper problem. A combustion damper fault on a Member boiler can only be cleared by power cycling.

The Master boiler controls a system damper and Member boilers control their own respective dampers. When the call for heat is removed, the damper will remain open for 30 seconds before closing. This allows for post purge cycles to complete.

OPEN *** SENSOR:** If the open sensor fault is displayed, the sensor in the position reported was originally detected, but has since opened. The boiler will shut down on any OPEN sensor.

FAULT	SYSTEM SET
OPEN OUTSIDE SENSOR	160°F

SHORTED *** SENSOR:** If the shorted sensor fault is displayed, the sensor in the position reported was originally detected, but has since shorted. The boiler will shut down on any SHORTED sensor.

FAULT	SYSTEM SET
SHORTED OUTSIDE SENSOR	160°F

DELTA TEMP > 40°F: If the temperature across the heat exchanger rises above the maximum designated temperature for the FIII model boiler, a warning or fault will be displayed. This protection is required to prevent damage to the heat exchanger in the event high differential temperatures are encountered. The fault or warning condition may be changed in the AUX FUNCTIONS menu under ALARM TYPE. The default condition is WARNING with LIM->HALF RATE = YES.

When this condition exists and the ALARM TYPE is set to WARNING and LIM-> HALF RATE, the boiler is limited to 1/2 it's input rate. So, if the boiler is trying to fire at 80%, the rate is limited to 40% until the temperature across the heat exchanger falls at least 10°F below the maximum designated temperature for the FIII boiler model. In this case: 40°F - 10°F = 30°F.

If the ALARM TYPE is set to FAULT, the boiler will display the FAULT message and this condition will be treated as an interlock, thus shutting down the boiler until the Delta Temp drops 10°F below the maximum designated temperature.

1/2 INPUT	LOCAL SET
DELTA TEMP > 40°F	41°F

RETURN TEMP < 130°F: If the Return Inlet temperature is less than 130°F this warning will be displayed. This warning does not affect operation and does not set the alarm relay. A log entry is made to aide in diagnosing why this may be occurring. Condensing will occur with return temperatures below 130°F and a shortened heat exchanger life will occur.

PREPURGE	LOCAL SET
RETURN TEMP < 130°F	41°F

MAINTENANCE

WARNING Disconnect electrical power and close the manual gas shut off valve before performing maintenance or severe personal injury may result!

CAUTION Servicing, inspection and adjustment must be done by a trained technician in accordance with all applicable local and national codes. Improper servicing or adjustment can damage the boiler/water heater!

The boiler/water heater must be cleaned and inspected at least once a year and before each heating season. Make sure that the burner and ignition components are free from dust, soot, dirt, corrosion or other deposits that would impair the boiler/water heater's performance. Refer to Figure 25 for component identification.

CAUTION Improper burner servicing can result in premature burner failure voiding the warranty!

Burner Removal

1. Close the manual shutoff valves in the gas supply line and turn off electrical power to the boiler/water heater.
2. Remove the jacket top panel.
3. Disconnect the wires to the fan and remove the four bolts that secure the fan to the transition piece.
4. Remove wires from the spark rods and remove the UV sense from the transition piece.
5. Disconnect the compression nut at the back of the transition piece to remove pilot gas tubing.
6. Remove the four nuts holding the transition piece to the heat exchanger.
7. Lift and remove the transition piece and burner together from the boiler/water heater, taking care not to damage the spark rods and or their alignment.
8. Disconnect the compression nut from the inside of the transition piece.
9. Remove the transition piece, taking care not to damage the spark rods and or their alignment.

Heat Exchanger Inspection

1. Close the manual shutoff valves in the gas supply lines and turn off electrical power to the boiler/water heater.
2. Remove burner following the instructions in the **Burner Removal** section.
3. Remove the front jacket panel and combustion chamber door.
4. Inspect the inside and outside of the heat exchanger for signs of damage, sooting or corrosion.
5. The outside surfaces of the copper tubes should be free of any soot deposits. A slight black smudge is normal with some types of gases. Black soot indicates poor combustion. Green deposits indicate condensation due to low return water temperatures. In either case the heat exchanger must be cleaned thoroughly and the problem resolved before the boiler/water heater is returned to service.

6. If there are no signs of damage, sooting or corrosion, reassemble the unit following the previous steps in reverse order.
7. A badly corroded or damaged heat exchanger must be replaced, see the **Heat Exchanger Repair & Replacement** section.

Heat Exchanger Cleaning

1. Close the shut off valves in the inlet and outlet piping. On heating systems close the system fill valve and relieve the system pressure from the boiler by carefully lifting the relief valve or opening the drain valve.
2. Disconnect the boiler/water heater from the system piping.
3. Remove the eight bolts on the rear pipe enclosure panel.
4. Remove the front jacket panel and combustion chamber door.
5. Slide the heat exchanger out of the unit.
6. Remove the "V" baffle straps and "V" baffles.
7. Thoroughly clean the heat exchanger with water from a high-pressure hose. Use a soft bristle brush if necessary.
8. Replace the cleaned heat exchanger and other components in the reverse order of their removal.

Heat Exchanger Repair & Replacement

1. A leaking or otherwise damaged tube(s) can be replaced as outlined in steps 2 through 8.
2. Remove the heat exchanger from the boiler/water heater as outlined in the **Heat Exchanger Cleaning** section.
3. Remove the pipe plugs from the inlet/outlet and return headers opposite from the ends of the tube(s) being replaced.
4. Carefully cut the damaged tube(s) in half, taking care not to damage the adjacent tubes and remove.
5. Install and swage/expand in place the new tube(s).
6. Replace the pipe plugs using a suitable thread sealant on each one.
7. Sagging or distorted heat exchanger tubes are an indication of low water flow through the system. A damaged heat exchanger must be replaced and the condition that caused the damage resolved before the boiler/water heater is returned to service.
8. Replace the heat exchanger and other components in the reverse order of their removal.
9. The recommended torque value for the heat exchanger plugs is approximately 45 ft. lbs, not to exceed 50 ft. lbs.

Air Intake & Vent System

Thoroughly inspect the air intake and vent systems for any signs of blockage, corrosion or leakage. Immediately replace any unsound vent system piping. Inspect the air filter and wash with warm water and soap if dirty.

Controls

Use the “GENERAL OPERATION” and “CHECKING AND ADJUSTMENTS” sections of this manual for reference.

1. Check the operating controls for proper operation.
2. A float type low water cutoff device must be flushed out per the manufacturers' instructions. The probe on a probe low water cut off must be removed, cleaned and inspected at least once a year. Ensure that the low water cutoffs operate properly. If not, replace them.
3. The flow switch contacts must be open when water flow is not present.
4. The relief valve should not weep or discharge water at normal system pressure. If it does, contact a qualified service technician to have it inspected. NEVER try to clean or repair the relief valve! If the valve fails to operate properly, have it replaced!
5. The aquastat high limit controls the maximum water temperature in the boiler. If the water temperature reaches the set temperature before the demand for heat has been met, the aquastat high limit should shut the boiler off. The water temperature should never exceed the maximum set point of **250°F, 121°C**, for boilers and **210°F, 99°C** for water heaters. The aquastat high limit cannot be repaired. If it fails to function properly, replace it.
6. Visually check the pilot and main burner flames to ensure proper operation, see Figure 24.

WARNING A yellow, floating flame indicates a lack of combustion air. Do not operate the boiler/water heater until the problem is solved or severe personal injury or death may occur!

Figure 24 Main Burner Flame

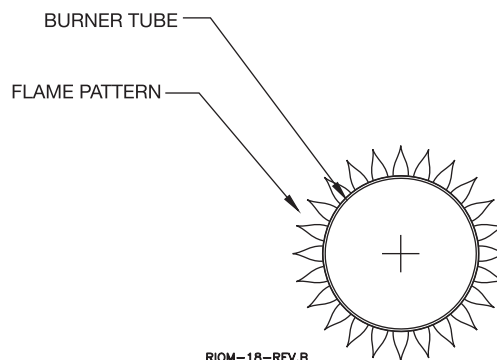

Troubleshooting A Startup

	Symptom	Identify Source	Check	Action
1.	An Interlock is tripped.	<p>1. Is it a 24 VAC Interlock?</p> <p>2. Is it a 120 VAC Interlock/ Alarm?</p> <p>3. Internal Alarms</p>	<p>1. All 24 VAC Interlocks are located on J11A and J11B. Examples of 24 VAC Interlocks: 1. SPARE3 2. Variable Frequency Drive(VFD) 3. Low Water Cutoff(LWCO), 4. Gas Pressure 5. Spare 4 6. Operator OPLIM 7. Water Flow 8. Air Pressure from UV Sensor.</p> <p>2. All 120 VAC interlocks/Alarms are located on J5. These include: 1. FLAME SAFE ALARM (Ignition CTRL ALARM) 2. Valve Alarm (IRI ALARM) 3. XS_FACTORY (Reserved) 4. HIGH LIMIT</p> <p>1. OPEN SENSOR 2. SHORTED SENSOR 3. COMBUSTION AIR DAMPER</p>	<p>1. Use a multimeter and check for 24 VAC on J11A, J11B to identify which interlock has tripped. Reset the Interlock or check for disconnected wiring or shorts.</p> <p>The Air Pressure from UV Sensor interlock if displayed will allow the boiler to function, but it needs to be functional while the boiler is running for it to clear.</p> <p>1. Use a multimeter on J5 to check for 120 VAC on these interlocks (except the HIGH LIMIT). The High Limit Interlock is displayed when there is no 120 VAC, since the HIGH LIMIT breaks the 120VAC to the Ignition Control.</p> <p>NOTE: Stray Voltages Greater than 8 VAC and less than 18 VAC on these interlocks can cause intermittent operation. If this is the case, check for back fed voltages from field wiring.</p> <p>Check sensor voltages at J10A and J10B. The Temperature sensor inputs should be between 0 VDC and 5 VDC measured across the sensor. Example: At 77°F, the voltage would read 2.5 VDC.</p> <p>The combustion air damper prove switch must be wired across SPARE 1 and must be a "DRY" contact. Do not apply a voltage to this input, the input supplies it's own voltage/current.</p>
2.	Proceed to HeatNet Control Manual for more details and problem resolution.			

REPAIR PARTS

Figure 25 Exploded View

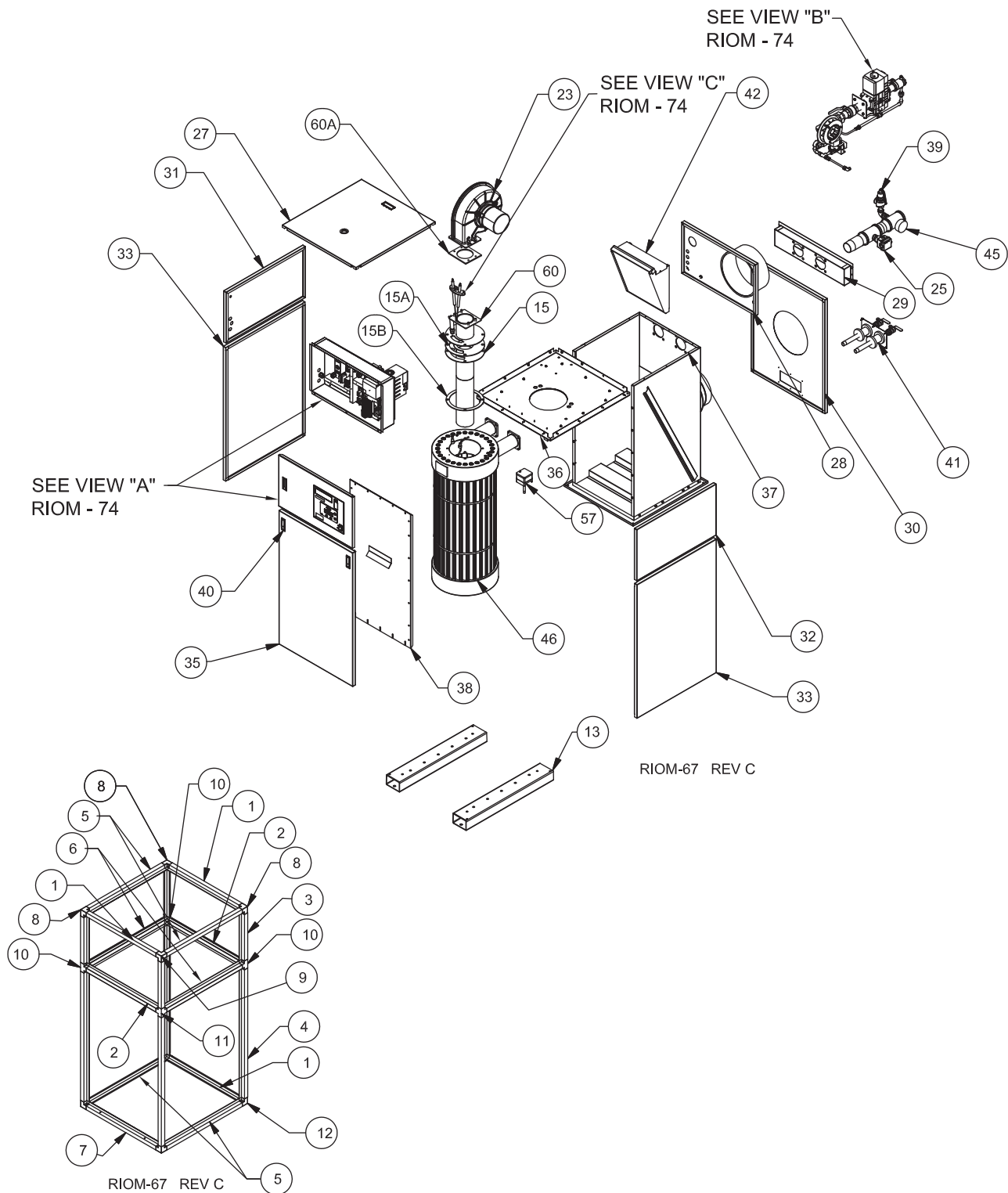

REPAIR PARTS (CONTINUED)

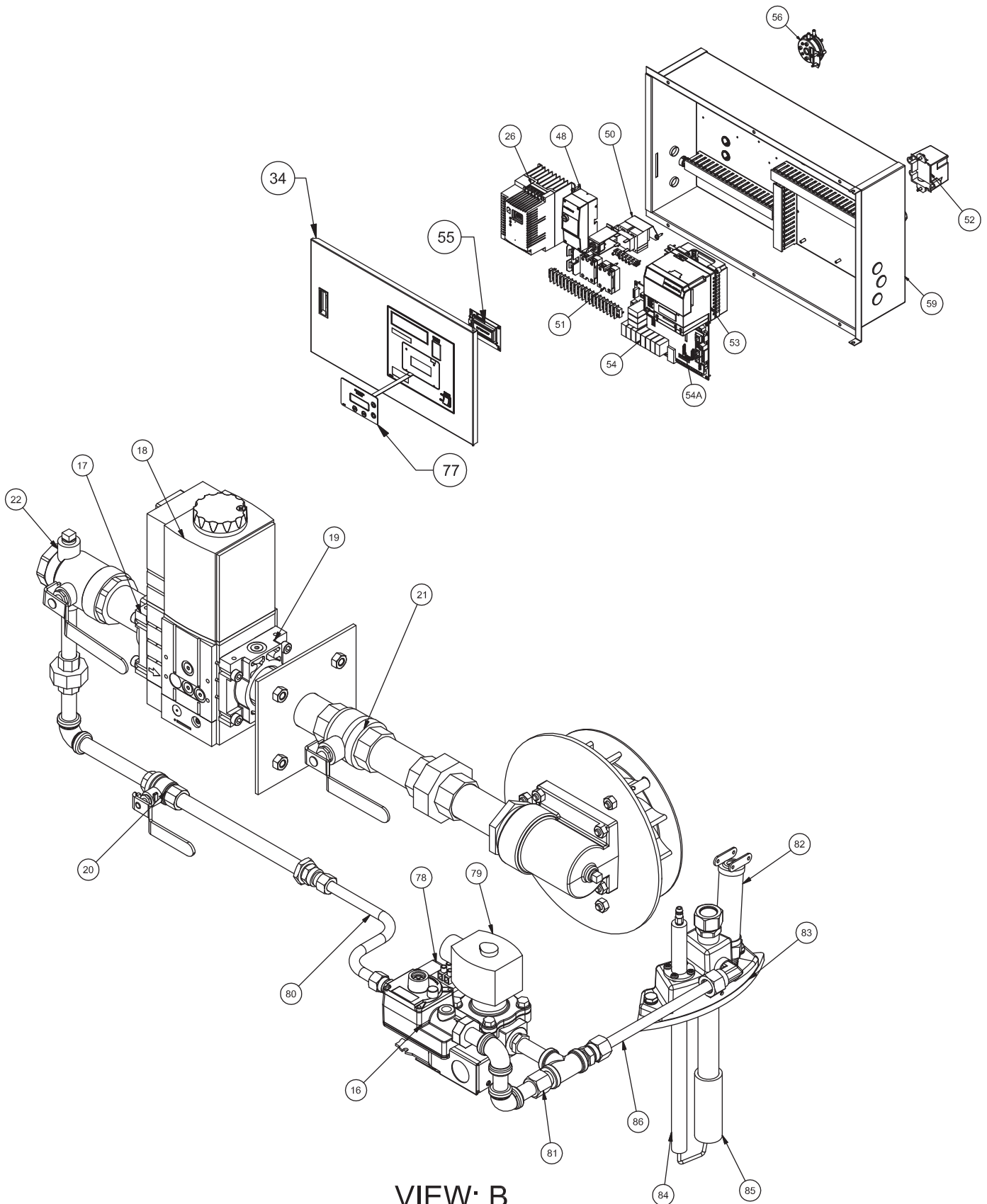

VIEW: B

REPAIR PARTS (CONTINUED)

Ref #	Name of Part	Part #	Model Size with Item Quantities Below						
			500	750	1000	1250	1500	1750	2000
15	Burner for Turbo Pilot	70-2529.1	1						
		70-2530.1		1					
		70-2531.1			1				
		70-2532.1				1			
		70-2533.1					1		
		70-2534.1						1	
		70-2535.1							1
15a	Transition Gasket	(must order as kit 21-2007)							
		(must order as kit 21-2008)							
15b	Burner Gasket	(must order as kit 21-2007)							
		(must order as kit 21-2008)							
16	Solenoid Valve w/Regulator, NG	11-0372	1	1	1	1	1	1	1
	Solenoid Valve w/Regulator, LP	11-0374	1	1	1	1	1	1	1
17	Flange 1" (Inlet)	11-0231	1	1	1	1	1		
	Flange 1-1/2" (Inlet)	11-0214						2	2
18	Gas Valve	11-0230	1	1	1	1			
		11-0227					1	1	1
	Test Port (CSD-1)	11-0354	1	1	1	1	1	1	1
19	Flange 1" (Outlet)	11-0228	1	1	1	1			
	Flange 1-1/2" (Outlet)	11-0229					1	1	1
NS	Orifice Gasket	06-0022	1	1	1	1	1	1	1
NS	Gas Injectors NG	10-1009	1	1	1	1			
	Gas Injectors NG	10-1002					1	1	1
	Gas Injectors LP	10-1010	1	1	1	1	1	1	1
20	Ball Valve	11-0395	1	1	1	1	1	1	1
21	Firing Valve, 1"	11-0456	1	1					
	Firing Valve, 1-1/2"	11-0458					1	1	1
22	"A" Valve, 1"	11-0465	1	1					
	"A" Valve, 1-1/4"	11-0466			1	1	1		
	"A" Valve, 1-1/2"	11-0467						1	1
23	Blower, Fasco 7043	70-2348	1	1	1				
	Blower, Fasco 7035	12-0017				1	1	1	1
25	Flow Switch	14-0203	1	1	1	1	1	1	1
	Flow Switch (Outdoor)	14-0205	1	1	1	1	1	1	1
	Flow Switch (Potter)	14-0201	1	1	1	1	1	1	1
	Flow Switch (Outdoor Potter)	14-0202	1	1	1	1	1	1	1
26	Frequency Drive	15-0231	1	1	1	1	1	1	1
27	Jacket Top Panel	70-2412	1	1	1				
		70-2413				1	1	1	1
36	Combustion Chamber Top Panel	70-2356	1	1	1				
		70-2357				1	1	1	1
	Manning Glass Insulation (per square foot)	05-0104	4	4	4	5	5	5	5

REPAIR PARTS (CONTINUED)

Ref #	Name of Part	Part #	Model Size with Item Quantities Below						
			500	750	1000	1250	1500	1750	2000
NS	2" Blanket Insulation (per sq ft)	05-0200	20	22	24	26	26	30	30
	Red Silicone Gasket (per ft / sold per roll 50')	06-0146	50	50	50	50	50	50	50
39	Pressure Relief Valve 50#	30-0360	1	1	1				
	Pressure Relief Valve 50#	30-0374				1			
	Pressure Relief Valve 50#	30-0379					1	1	1
	Pressure Relief Valve 125#	30-0364	1	1	1	1	1	1	1
40	Latch	20-0046	2	2	2	2	2	2	2
42	Air Filter Upgrade Kit	21-2005	1	1	1				
		21-2006				1	1	1	1
	Air Filter	09-0483	1	1	1				
		09-0484				1	1	1	1
45	Tridicator 30 - 60 psi	13-0308	1	1	1	1	1	1	1
	Tridicator 75 - 160 psi	13-0305	1	1	1	1	1	1	1
46	Heat Exchanger Assembly (Copper) Cast Iron (prior to 0209 must replace combustion chamber top panel #36)	70-2515.1R	1						
		70-2516.1R		1					
		70-2517.1R			1				
		70-2518.1R				1			
		70-2519.1R					1		
		70-2520.1R						1	
		70-2521.1R							1
	Heat Exchanger Assembly (Copper) Bronze	70-2186.1R	1						
		70-2187.1R		1					
		70-2188.1R			1				
		70-2189.1R				1			
		70-2190.1R					1		
		70-2191.1R						1	
		70-2192.1R							1
Individual copper/cupronickel tubes* available for field repair *model and serial number required									
	Tube Expansion Tool	30-0761	1	1	1	1	1	1	1
	Heat Exchanger Assembly (Cupronickel) Cast Iron (prior to 0209 must replace combustion chamber top panel #36)	70-2522.1R	1						
		70-2523.1R		1					
		70-2524.1R			1				
		70-2525.1R				1			
		70-2526.1R					1		
		70-2527.1R						1	
		70-2528.1R							1
	Heat Exchanger Assembly (Cupronickel) Bronze	70-2193.1R	1						
		70-2194.1R		1					
		70-2195.1R			1				
		70-2196.1R				1			
		70-2197.1R					1		
		70-2198.1R						1	
		70-2199.1R							1

REPAIR PARTS (CONTINUED)

Ref #	Name of Part	Part #	Model Size with Item Quantities Below						
			500	750	1000	1250	1500	1750	2000
NS	Inlet Adapters (Flanged)	01-0044GL	1	1	1				
		01-0045GL				1	1	1	1
	Outlet Adapters (Flanged)	01-0046GL	1	1	1				
		01-0047GL				1	1	1	1
	Outlet Adapters (Threaded)	01-0042	1	1	1				
		01-0043				1	1	1	1
Inlet/Outlet Header Gasket		(must order as kit 21-2007)							
		(must order as kit 21-2008)							
NS	Heat Exchanger "V" Baffle	03-1612	20						
		03-1613		20					
		03-1614			20				
		03-1615				28			
		03-1616					28		
		03-1617						28	
		03-1618							28
	Heat Exchanger "V" Baffle Strap	03-1619	2	2	2				
		03-1620				2	2	2	2
48	High Limit, Jumo, (MB)	14-0013	1	1	1	1	1	1	1
	High Limit, Jumo, (MW)	14-0014	1	1	1	1	1	1	1
NS	Operator, T6031A (pool heater)	14-0003	1	1	1	1	1	1	1
NS	High Limit Well, 3/8 x 3	13-0104	2	2	2	2	2	2	2
NS	10K Temperature Sensor	14-0325	3	3	3	3	3	3	3
50	Transformer, 50 VA	15-0007	1	1	1	1	1	1	1
51	Purge Timer, ST7800	16-0007	1	1	1	1	1	1	1
52	Spark Generator, Q652B	16-0036	1	1	1	1	1	1	1
53	Flame Safeguard, RM78957C	16-0024R	1	1	1	1	1	1	1
NS	Keyboard Display Module, S7800A	16-0010	1	1	1	1	1	1	1
54	Main Board (HeatNet)	16-0047	1	1	1	1	1	1	1
55	Display Board (HeatNet)	40-0088	1	1	1	1	1	1	1
NS	Ribbon Cable	40-0115	1	1	1	1	1	1	1
NS	Power Switch	48-0013	1	1	1	1	1	1	1
NS	Toggle Switch Remote / Local	48-0014	1	1	1	1	1	1	1
56	Air Pressure Switch	11-0416	1	1	1	1	1	1	1
NS	Low Gas Pressure Switch (Manual Reset)	11-0422	1	1	1	1	1	1	1
NS	High Gas Pressure Switch (Manual Reset)	11-0411	1	1	1	1	1	1	1
NS	High Gas Pressure Switch Adapter	11-0423	1	1	1	1	1	1	1
NS	UV Amplifier, R7849A	16-0006	1	1	1	1	1	1	1
NS	Ignition Cable	44-0063	1	1	1	1	1	1	1
60	Transition Assembly (prior to 0209 must upgrade to turbo pilot by replacing burner, spark rod and transition assembly)	70-2305	1	1	1				
		70-2306				1	1	1	1

REPAIR PARTS (CONTINUED)

Ref #	Name of Part	Part #	Model Size with Item Quantities Below						
			500	750	1000	1250	1500	1750	2000
60a	Gasket		(must order as kit 21-2007)						
			(must order as kit 21-2008)						
61	Pump Contactor Relay	15-0137	1	1	1	2	2	2	2
NS	Rating Plate	82-0054	1	1	1	1	1	1	1
NS	Futera III Overlay (HeatNet)	82-0200	1	1	1	1	1	1	1
77	Keypad Overlay	82-0189	1	1	1	1	1	1	1
78	Mini Fan	12-0021	1	1	1	1	1	1	1
79	Air Solenoid Valve	11-0376	1	1	1	1	1	1	1
80	3/8" Aluminum Tubing	62-0102	1	1	1	1	1	1	1
81	Pilot Orifice, .052 NG	10-0140	1	1	1	1	1	1	1
	Pilot Orifice, .040 LP	10-0139	1	1	1	1	1	1	1
82	Mini Peeper, C7027A	16-0009	1	1	1	1	1	1	1
83	Spark Plate Gasket	06-0102	1	1	1				
		06-0037				1	1	1	1
NS	Spark Rod Assembly	70-2566	1	1	1				
		70-2567				1	1	1	1
84	Electrode	16-0335	1	1	1	1	1	1	1
NS	Spark Rod O'ring	06-0008	1	1	1	1	1	1	1
86	1/2" Aluminum Tubing	62-0103	1	1	1	1	1	1	1
NS	Silicone	66-0151	1	1	1	1	1	1	1
NS	Silicone Tubing	06-0051	2	2	2	2	2	2	2
NS	Vent Termination Hood 5"	09-0117	1	1					
	Vent Termination Hood 6"	09-0112			1	1			
	Vent Termination Hood 8"	09-0113					1		
	Vent Termination Hood 10"	09-0115						1	1
NS	Air Intake Hood 6"	09-0102	1	1	1				
	Air Intake Hood 8"	09-0103				1			
	Air Intake Hood 10"	09-0104					1		
	Air Intake Hood 12"	09-0105						1	1

START-UP REPORT



DATE:	JOB NAME:
TECHNICIAN:	LOCATION:
COMPANY:	MODEL: CATEGORY:
PHONE NUMBER:	SERIAL #:

PRE-STARTUP CHECK LIST

- | | |
|--|--|
| <input type="checkbox"/> NO VISIBLE DAMAGE TO UNIT | <input type="checkbox"/> INLET AIR FILTER INSTALLED AND CLEAN |
| <input type="checkbox"/> PIPING PROPERLY CONNECTED | <input type="checkbox"/> PROPER SERVICE CLEARANCES PROVIDED |
| <input type="checkbox"/> BOILER CIRCULATOR WIRED | <input type="checkbox"/> PUMP RUNNING, HEAT EXCHANGER FULL |
| <input type="checkbox"/> VENT/STACK CONNECTED | <input type="checkbox"/> GAS LINES PURGED, NO LEAKS, NO MISSING TEST PLUGS |

BOILER STARTUP SEQUENCE

Note: Locate the AA terminals and minimum hold switch in the bottom-right of the electrical panel on the main HeatNet board. Also locate the manometer test manifold in the bottom of the electrical panel.

1. Disable any external call for heat and toggle the remote/local switch to REMOTE.
2. Toggle the LOW FIRE switch to cycle the boiler then hold at trial for pilot ignition.
3. Set pressure to 3–3.5" w.c. (flame signal should read 5.0 VDC).
4. Release boiler to main flame trial for ignition.
5. Check for stable flame.
6. Record combustion and manifold pressure at minimum firing rate.
7. Jumper the AA terminals to force 100% input.
8. Record combustion and manifold pressure.
9. Remove the AA jumper to place the boiler at minimum rate.
10. Make any final adjustments on low fire.
11. Check all combustion results using a calibrated flue gas analyzer.
12. Release the LOW FIRE switch to place boiler in standby.

NOTICE

In addition to completing the Fusion/Futera III start-up report, complete the control set-up information in the rear of the HeatNet manual.

COMBUSTION ANALYSIS	MINIMUM FIRING RATE	100% FIRING RATE
GAS PRESSURE AT SUPPLY TEST PORT	INCHES W.C.	INCHES W.C.
CO ₂	%	%
O ₂	%	%
CO (PPM)	PPM	PPM
NET STACK TEMPERATURE	°F	°F
MANIFOLD PRESSURE (W.C.)	INCHES W.C.	INCHES W.C.

SAFETY TEST CHECKLIST

- FLOW SWITCHES
- AIR SWITCH
- FLAME SAFEGUARD
- LOW WATER CUT-OFF
- HIGH LIMITS

NOTICE Verify that the piping and controls ensure the boiler return water temperature does NOT drop below 140°F, 60°C. Operating at lower return temperatures is likely to cause condensation in the primary heat exchanger, resulting in corrosion and possible failure of the heat exchanger.

COMMISSIONING THE BOILER/WATER HEATER

<ul style="list-style-type: none"> <input type="checkbox"/> UNIT CYCLED MINIMUM OF 15 TIMES <input type="checkbox"/> CUSTOMER INSTRUCTED <input type="checkbox"/> ALL COVERS REPLACED <input type="checkbox"/> CUSTOMER GIVEN MANUAL <input type="checkbox"/> TARGET TEMPERATURE SET PER CUSTOMER <p>COMMISSIONED BY: _____ (SIGNATURE)</p> <p>DATE: _____</p>	<p>THE DELTA T BETWEEN THE HEATER INLET AND OUTLET IS CRITICAL TO PROPER FLOW. BEFORE YOU LEAVE THE JOBSITE, YOU MUST RECORD THE DELTA T. THIS READING SHOULD NOT EXCEED 35°F, 19.4°C, NOR BE LOWER THAN 20°F, 11.2°C.</p> <p style="text-align: center;">DELTA T = <input style="width: 100px; height: 20px;" type="text"/></p>
---	--

ADDITIONAL NOTES AND COMMENTS

NOTICE!

Commonwealth of Massachusetts Installation Requirements

MACODE-3

NOTICE In the Commonwealth of Massachusetts, the installation must be performed by a licensed plumber or gas fitter.

1. For all side wall horizontally vented gas fueled equipment installed in every dwelling, building or structure used in whole or in part for residential purposes, including those owned or operated by the commonwealth and where the side wall exhaust vent termination is less than seven (7) feet above finished grade, in the area of the venting, including but not limited to decks and porches, the following requirements shall be satisfied:
 - d. **INSTALLATION OF CARBON MONOXIDE DETECTORS.** At the time of installation of the side wall horizontal vented gas fueled equipment, the installing plumber or gasfitter shall observe that a hard wired carbon monoxide detector with an alarm and battery back-up is installed on the floor level where the gas equipment is to be installed. In addition, the installing plumber or gasfitter shall observe that a battery operated or hard wired carbon monoxide detector with an alarm is installed on each additional level of the dwelling, building or structure served by the side wall horizontal vented gas fueled equipment. It shall be the responsibility of the property owner to secure the services of qualified licensed professionals for the installation of hard wired carbon monoxide detectors.
 - i. In the event that the side wall horizontally vented gas fueled equipment is installed in a crawl space or an attic, the hard wired carbon monoxide detector with alarm and battery back-up may be installed on the next adjacent floor level.
 - ii. In the event that the requirements of this subdivision can not be met at the time of completion of installation, the owner shall have a period of thirty (30) days to comply with the above requirements; provided, however, that during said thirty (30) day period, a battery operated carbon monoxide detector with an alarm shall be installed.
 - e. **APPROVED CARBON MONOXIDE DETECTORS.** Each carbon monoxide detector as required in accordance with the above provisions shall comply with NFPA 720 and be ANSI/UL 2034 listed and IAS certified.
 - f. **SIGNAGE.** A metal or plastic identification plate shall be permanently mounted to the exterior of the building at a minimum height of eight (8) feet above grade directly in line with the exhaust vent terminal for the horizontally vented gas fueled heating appliance or equipment. The sign shall read, in print size no less than one-half (1/2) inch in size, "GAS VENT DIRECTLY BELOW. KEEP CLEAR OF ALL OBSTRUCTIONS".
 - g. **INSPECTION.** The state or local gas inspector of the side wall horizontally vented gas fueled equipment shall not approve the installation unless, upon inspection, the inspector observes carbon monoxide detectors and signage installed in accordance with the provisions of 248 CMR 5.08(2)(a)1 through 4.

WARNING Improper venting can result in excessive levels of carbon monoxide which can cause severe personal injury or death!

2. Exemptions — The following equipment is exempt from 248 CMR 5.08(2)(a) 1 through 4:
 - a. The equipment listed in Chapter 10 entitled "Equipment Not Required To Be Vented" in the most current edition of NFPA 54 as adopted by the Board; and
 - b. Product Approved side wall horizontally vented gas fueled equipment installed in a room or structure separate from the dwelling, building or structure used in whole or in part for residential purposes.
3. **MANUFACTURER REQUIREMENTS - GAS EQUIPMENT VENTING SYSTEM PROVIDED.**
 - a. When the manufacturer of Product Approved side wall horizontally vented gas equipment provides a venting system design or venting system components with the equipment, the instructions provided by the manufacturer for installation of the equipment and the venting system shall include:
 - i. Detailed instructions for the installation of the venting system design or the venting system components; and
 - ii. A complete parts list for the venting system design or venting system.
4. **MANUFACTURER REQUIREMENTS – GAS EQUIPMENT VENTING SYSTEM NOT PROVIDED.**
 - a. When the manufacturer of a Product Approved side wall horizontally vented gas fueled equipment does not provide the parts for venting the flue gases, but identifies "special venting systems", the following requirements shall be satisfied by the manufacturer:
 - i. The referenced "special venting system" instructions shall be included with the appliance or equipment installation instructions; and
 - ii. The "special venting systems" shall be Product Approved by the Board, and the instructions for that system shall include a parts list and detailed installation instructions.
5. A copy of all installation instructions for all Product Approved side wall horizontally vented gas fueled equipment, all venting instructions, all parts lists for venting instructions, and/or all venting design instructions shall remain with the appliance or equipment at the completion of the installation.

WARNING Improper venting can result in excessive levels of carbon monoxide which can cause severe personal injury or death!

LIMITED WARRANTY

Boilers/Water Heaters Industrial, Commercial and Other Non-Residential Use

The "Manufacturer" warrants to the original owner at the original installation site that the heat exchanger of the Industrial, Commercial, and other Non-Residential Use Boiler (the "Product") will be free from defects in material or workmanship for ten (10) years from the date of installation. Additional twenty one (21) year thermal shock warranty on heat exchanger. If upon examination by the Manufacturer the Product is shown to have a defect in material or workmanship during the warranty period, the Manufacturer will repair or replace, at its option, that part of the Product which is shown to be defective. All other RBI supplied Boiler/Water Heater parts are warranted against defects in material and workmanship for one (1) year from date of installation or 18 months from date of shipment from RBI.

The "Manufacturer" warrants to the original owner at the original installation site that the heat exchanger of the Industrial, Commercial, and other Non-Residential Use Water Heater (the "Product") will be free from defects in material or workmanship for five (5) years from the date of installation. Additional twenty one (21) year thermal warranty on heat exchanger. If upon examination by the Manufacturer the Product is shown to have a defect in material or workmanship during the warranty period, the Manufacturer will repair or replace, at its option, that part of the Product which is shown to be defective. All other RBI supplied Boiler/Water Heater parts are warranted against defects in material and workmanship for one (1) year from date of installation or 18 months from date of shipment from RBI.

This limited warranty does not apply:

- (a) if the Product has been subjected to misuse or neglect, has been accidentally or intentionally damaged, has not been installed, maintained or operated in accordance with the furnished written instructions, or has been altered or modified in any way.

These include but not limited to:

- Excessive water hardness causing a lime build-up in the heat exchanger tubes is not a fault of the equipment and is not covered under the manufacturer's warranty.
 - Excessive pitting and erosion on the inside of the heat exchanger tubes caused by high water velocity through the tubes and is not covered by the manufacturer's warranty. (See Installation Instructions for proper pump performance.)
 - Chemical corrosion, no corrosive chemical (freon, dry cleaning chemicals, degreasing liquids, chlorine or any chemicals that produce hydrochloric acid) can be present in the boiler room as it rapidly destroys the heating equipment and voids the warranty.
 - All copper fin boilers should not operate with a return water temperature less than 110°F, 43°C atmospheric combustion, 125°F, 52°C fan assist combustion. If a lower temperature is required, an external bypass should be installed to prevent condensation. The manufacturer's warranty does not cover damage done by condensation.
- (b) to any expenses, including labor or material, incurred during removal or reinstallation of the Product or parts thereof.
- (c) to damage as a result of settlement, distortion, collapse, or cracking of any foundation area, beams or pipes surrounding the Product.
- (d) to any workmanship of any installer of the Product; or to Products installed outside the continental United States or Canada.

This limited warranty is conditional upon:

- (a) shipment, to the Manufacturer, of that part of the Product thought to be defective. Goods can only be returned with prior written approval from the Manufacturer. All returns must be freight prepaid.
- (b) determination in the reasonable opinion of the Manufacturer that there exists a defect in material or workmanship.

Repair or replacement of any part under this Limited Warranty shall not extend the duration of the warranty with respect to such repaired or replaced part beyond the stated warranty period.

THIS LIMITED WARRANTY IS IN LIEU OF ALL OTHER WARRANTIES, EITHER EXPRESS OR IMPLIED, AND ALL SUCH OTHER WARRANTIES, INCLUDING WITHOUT LIMITATION IMPLIED WARRANTIES OF MERCHANTABILITY OR FITNESS FOR A PARTICULAR PURPOSE, ARE HEREBY DISCLAIMED AND EXCLUDED FROM THIS LIMITED WARRANTY. IN NO EVENT SHALL THE MANUFACTURER BE LIABLE IN ANY WAY FOR ANY CONSEQUENTIAL, SPECIAL, OR INCIDENTAL DAMAGES OF ANY NATURE WHATSOEVER, OR FOR ANY AMOUNTS IN EXCESS OF THE SELLING PRICE OF THE PRODUCT OR ANY PARTS THEREOF FOUND TO BE DEFECTIVE. THIS LIMITED WARRANTY GIVES THE ORIGINAL OWNER OF THE PRODUCT SPECIFIC LEGAL RIGHTS. YOU MAY ALSO HAVE OTHER RIGHTS WHICH MAY VARY BY EACH JURISDICTION.



260 North Elm Street
Westfield, MA 01085
Phone: (413) 568-9571
Fax: (413) 568-9613

www.rbiwaterheaters.com

7555 Tranmere Drive
Mississauga, Ontario L5S 1L4 Canada
Phone: (905) 670-5888
Fax: (905) 670-5782



A MESTEK COMPANY