

SERIES 19HE

Smith

**Smith**  
CAST IRON BOILERS



series 19HE

PRESSURIZED WET BASE  
BOILER/BURNER UNIT





# series 19HE

Smith 19HE Series cast iron, pressurized, wet-base boiler/burner units are ideal for light commercial water or steam heating systems utilizing No. 2 fuel oil, natural gas, or combination gas/oil. Ten different sizes are available, ranging from 308 MBH I=B=R gross output units to 1750 MBH I=B=R gross output units. Series 19HE boilers are available in three ways — knocked down, assembled sections, or completely packaged units. All sections are tested and approved for 80 psi working pressure as standard equipment.

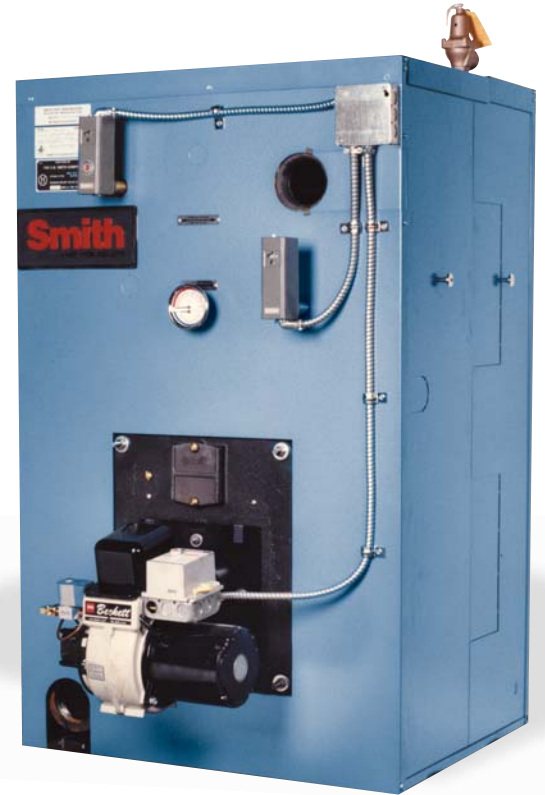

## STANDARD EQUIPMENT

### All Boilers

- Cast iron wet-base sections tested for 80psi.
- Insulated metal jacket
- Cast iron smokehood with integral damper
- Burner mounting plate with insulation block
- Front and rear flame observation ports
- Steel angle floor rails
- Hi-Temp hydronic port seals
- Flue brush
- Target Wall (3-6 sections)

### Water Boiler/Burner Units

- ASME relief valve, 40 psi
- Theraltimeter
- Manual reset, Hi-Limit control
- Lo-Limit operating control

### Steam Boiler/Burner Units

- ASME side outlet safety valve, 15 psi
- Steam gauge (0-30 psig)
- Gauge glass with gauge cocks and guards
- Manual reset, Hi-Limit control
- Lo-Limit operating control

*All sizes exceed the Ashrae 90.1 efficiency requirements*

## Designed and Constructed for Easy Service and Long Life.

19HE Series boiler/burner units are designed and constructed for easy service. A front observation port allows the serviceman to visually check the flame and combustion area. Easy-to-remove, side-mounted cover plates make boiler clean-out quick and easy. Side-mounted tankless 9 GPM coils allow for easy visual inspection and service. Heavy-duty, hydrocarbon-resistant Viton port seal gaskets are exceptionally easy to install. The integral, cast-iron, fail-safe breeching damper may be easily adjusted and securely locked in position. Individual section draw rods simplify assembly while reducing stress.

### Reliable, Fuel-Efficient Heat

Smith 19HE Series boiler/burner units are designed and constructed for high efficiency and superior performance. High-quality cast iron sections, cast-in heat extraction pins, completely insulated metal jacket, ceramic fiber rope section seals, obround-shaped upper ports, and carefully selected, high-efficiency burner add up to a boiler/burner unit that will provide reliable, fuel-efficient heat for years to come.

Compare Smith 19HE Series units with other brands with similar capacities — you'll discover that Smith is your smartest choice.



# PRESSURIZED WET-BASE BOILER BURNER UNITS

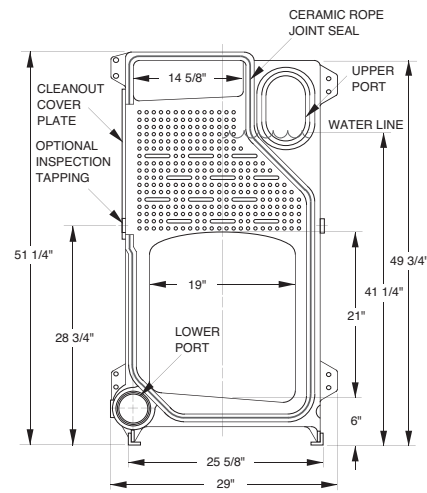
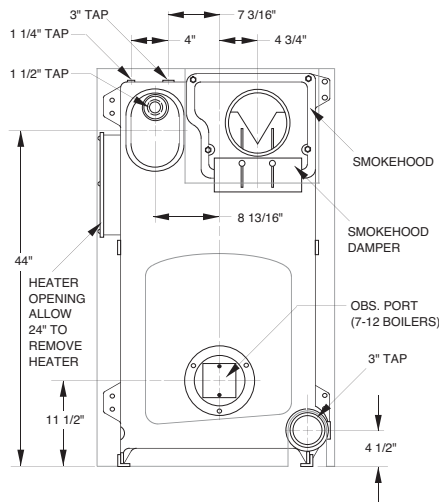
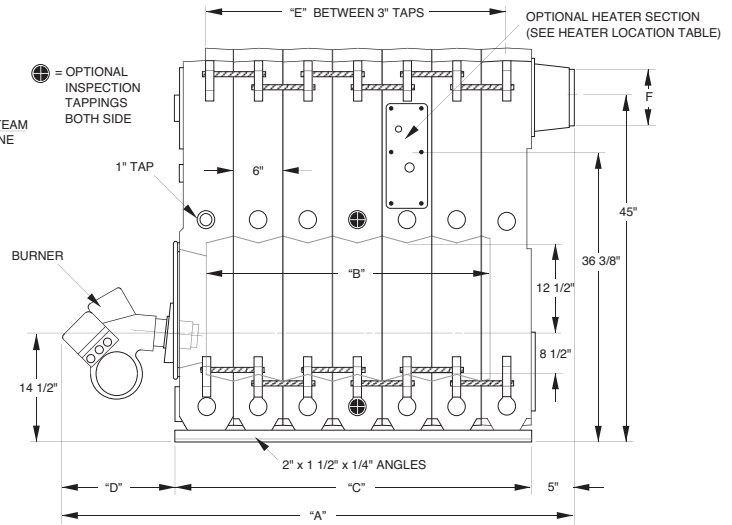
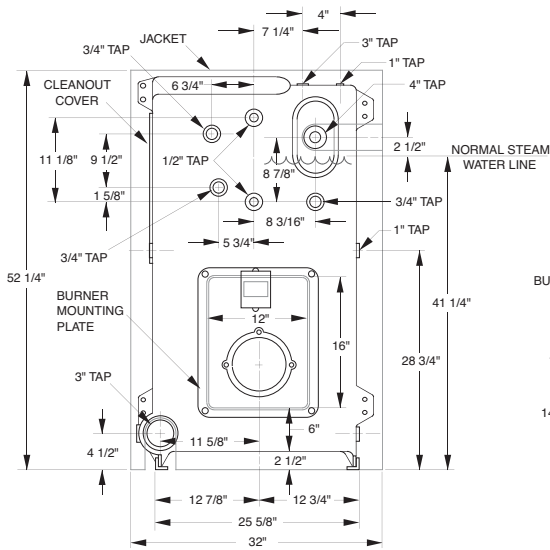

## Dimensions (inches)

Boiler Number	Overall Length "A"				"B"	"C"	Burner Length "D"				"E" Distance Between Supply Tappings	"F" Flue Pipe Diameter
	Carlin	PF/J	PF/C	Beckett Oil			Carlin	PF/J	PF/C	Beckett Oil		
†19HE-3	39	44	—	31	9	18	16	21	—	13	12	7
†19HE-4	45	50	59	37	15	24	16	21	30	13	18	7
†19HE-5	51	56	65	43	21	30	16	21	30	13	24	8
†19HE-6	61	62	71	49	27	36	20	21	30	13	30	8
†19HE-7	67	68	82	64	33	42	20	21	35	22	36	9
†19HE-8	73	74	88	71	39	48	20	21	35	23	42	10
†19HE-9	79	80	94	77	45	54	20	21	35	23	48	10
†19HE-10	87	86	100	83	51	60	22	21	35	23	54	10
†19HE-11	93	—	106	89	57	66	22	—	35	23	60	10+
†19HE-12	99	—	112	99	63	72	22	—	35	27	66	10+

The manufacturer should be consulted before selecting a boiler for installations having unusual piping and pickup requirements, such as intermittent system operation, extensive piping, etc. For forced hot water heating systems where the boiler and all the piping are within the area to be heated, the boiler may be selected on the basis of its Gross Output.

+ 11 and 12 section requires 12" diameter vent pipe. Transition collar provided by Smith.  
**NOTE: Dimensions are approximate. Should not be used to "rough-in" equipment.**

## Assembled Block or Packaged Boiler without Burner

NO. OF SECTIONS	CHANNEL LENGTH DIM. "A"	ANGLE LENGTH DIM. "B"
3	39	18
4	45	24
5	51	30
6	57	36
7	63	42
8	69	48
9	75	54
10	81	60
11	87	66
12	93	72

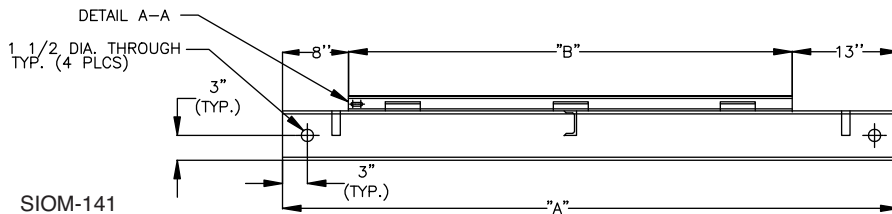

## Packaged Boiler with Burner

NO. OF SECTIONS	CHANNEL LENGTH DIM. "A"			ANGLE LENGTH DIM. "B"
	CARLIN/BECKETT	POWERFLAME J-SERIES	POWERFLAME C-SERIES	
3	49	59		18
4	55	65	74	24
5	61	71	80	30
6	67	77	86	36
7	73	83	92	42
8	79	89	98	48
9	85	95	104	54
10	91	101	110	60
11	97	107	116	66
12	103	113	122	72

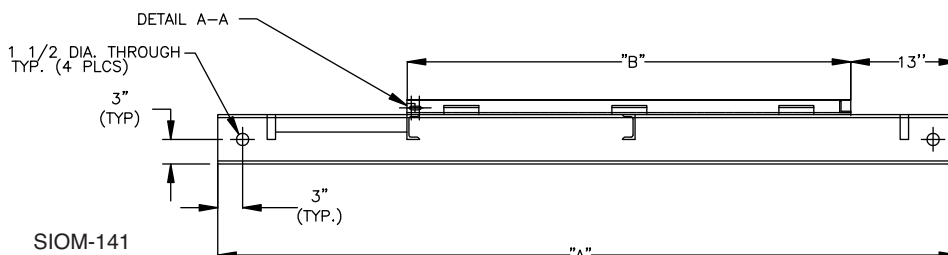

## I B R Ratings, Burner Capacities

Designed and tested to the A.S.M.E. boiler and pressure vessel code, section IV for maximum allowable working pressure, steam 15 psig, water 80 psig.

Boiler Number	Boiler Horsepower	Heating Surface (Sq. Ft.)	Furnace Volume (Cu. Ft.)	I=B=R Gross Output (MBH)	Net I=B=R Rating (1)			I=B=R Burner Capacity		Draft Loss (in W.C.)	Overfire(4) Pressure (in W.C.)	Water Content (Gals.)		Water Working Weight (Lbs.)	
					Steam		Water	OilGPH(2)	GasMBH(3)			Steam	Water	Steam	Water
					(Sq. Ft.)	MBH	MBH								
†19HE*-3	9.2	23.9	2.12	308	963	231	268	2.60	375	0.18	0.28	33.2	38.6	1673.6	1716.8
†19HE*-4	12.5	35.8	3.50	421	1316	316	369	3.60	520	0.18	0.28	41.1	49.2	2057.8	2122.6
†19HE*-5	17.5	47.7	4.88	587	1835	441	510	5.00	725	0.20	0.30	49.0	59.8	2442.0	2528.4
†19HE*-6	22.8	59.7	6.27	762	2382	572	663	6.50	931	0.23	0.33	56.8	70.3	2825.4	2933.4
†19HE*-7	27.6	71.6	7.65	924	2888	694	803	7.90	1137	0.26	0.36	64.7	80.9	3209.6	3339.2
†19HE*-8	32.5	83.5	9.04	1087	3398	817	945	9.30	1342	0.29	0.39	72.6	91.5	3593.8	3745.0
†19HE*-9	37.7	95.4	10.42	1262	3945	947	1087	10.80	1548	0.32	0.42	80.5	102.0	3978.0	4150.0
†19HE*-10	42.5	107.4	11.81	1424	4504	1081	1238	12.20	1754	0.35	0.45	88.3	112.6	4361.4	4555.8
†19HE*-11	47.4	119.3	13.20	1587	5071	1217	1380	13.60	1989	0.38	0.48	96.2	123.1	4745.6	4960.8
†19HE*-12	52.3	131.2	14.58	1750	5633	1352	1522	15.00	2165	0.41	0.51	104.0	133.7	5129.0	5366.6

† No insert for oil. Insert prefix "G" for gas or "GO" for combination gas/oil.  
 \* Insert "S" for steam, "W" for water. Example: GO19A-S-10 is a 10-section 19A Series Boiler for steam using combination gas/oil burner.

- (1) The net I=B=R Steam Ratings shown are based on a piping and pickup allowance of 1.333. The I=B=R Water Ratings shown are based on an allowance of 1.15.
- (2) Based on light oil having a heat content of 140,000 BTU per gallon.
- (3) Gas having a heat content of 1,000 BTU/cu. ft. at 0.6 specific gravity.
- (4) Includes 0.10" W.C. pressure on upstream side of exit damper.

## Side-Mounted Tankless Heater Capacities

No. of Sections	I=B=R Gross Output MBH	Cont. Draw (GPM)		
		One Heater	Two Heaters	Three Heaters
3	308	8.5	N/A	N/A
4	421	8.5	N/A	N/A
5	587	9.0	10.6	N/A
6	762	9.0	12.9	N/A
7	924	9.0	15.3	N/A
8	1087	9.0	17.6	N/A
9	1262	9.0	18.0	19.9
10	1424	9.0	18.0	22.2
11	1587	9.0	18.0	24.6
12	1750	9.0	18.0	26.9

Heater ratings based on 100° F. temperature rise, 200° F. boiler water, 9 GPM at 9.5 psi ∅ P. For 180° boiler water ratings, consult factory.

## Heater Section Location

Boiler Number	Max. No. of heaters	Location by boiler section (Heaters install from right side)
19HE-3	1	F - <b>H</b> - B
19HE-4	1	F - P - <b>H</b> - B
19HE-5	2	F - <b>H</b> - P - <b>H</b> - B
19HE-6	2	F - P - <b>H</b> - P - <b>H</b> - B
19HE-7	3	F - <b>H</b> - P - <b>H</b> - P - <b>H</b> - B
19HE-8	3	F - P - <b>H</b> - P - <b>H</b> - P - <b>H</b> - B
19HE-9	3	F - P - <b>H</b> - P - <b>H</b> - P - <b>H</b> - P - B
19HE-10	3	F - P - P - <b>H</b> - P - <b>H</b> - P - <b>H</b> - P - B
19HE-11	3	F - P - P - P - <b>H</b> - P - <b>H</b> - P - <b>H</b> - P - B
19HE-12	3	F - P - P - P - P - <b>H</b> - P - <b>H</b> - P - <b>H</b> - P - B

F = Front, P = Intermediate Plain, **H** = Intermediate Heater, B = Back



## Burners:

### Carlin Light Oil Burner

- High performance, forced draft, UL listed, flame retention oil burner:
  - On-off firing, (4 thru 5 sections), with cadmium cell primary control, oil valve, delay timer. Lo-hi firing (6 thru 12 sections)
  - Single stage fuel unit (3 thru 5 sections)
  - Two stage fuel unit (6 thru 12 sections)

### Beckett Light Oil Burner

- High performance, forced draft, UL listed, flame retention oil burner:
  - On-off firing, (3 thru 5 sections) with cadmium cell primary control, oil valve. Lo-hi off firing (6 thru 12 sections)
  - Single stage fuel unit (3 and 4 sections)
  - Two stage fuel unit (5 thru 12 sections)

### Power Flame Gas Burner

- High performance, forced draft, UL listed, power gas burner for natural gas firing:
  - On-off firing, (3 thru 12 sections), fixed air shutter combustion control, 115 volt diaphragm gas shut-off valve, 115 volt solenoid auxiliary gas valve, spark ignited intermittent gas pilot (gas train not assembled), pilot gas train with solenoid valve, pressure regulator and manual shut-off cock, pilot tubing and fittings

### Power Flame Gas/Oil Burner

- Both fuels — Spark ignited gas pilot, intermittent UV flame detection, prepurge.
  - On-off firing (4 thru 12 sections), with fixed air shutter, two stage fuel pump for oil, oil valve, slow opening diaphragm gas valve for gas, auxiliary solenoid gas valve. Gas train not assembled
  - Pilot gas train with solenoid valve, pressure regulator and manual shut-off cock, pilot tubing and fittings

# series 19HE

## OPTIONAL EQUIPMENT

### All Boilers

- Tankless water heaters
- Heater cover plates
- Sections assembled
- Packaged
- Burner start-up and one-year service
- Low water cutoffs
- Feeder and pump controllers
- Inspection taps and brass plugs (up to four per section)
- Water boilers—80 psi pressure relief valve

### Beckett & Carlin Oil Burners

- Electronic controls
- Two stage fuel unit (4 thru 6 sections)
- N.Y.C.— D.E.P. (formerly B.A.R.) approval
- Burner mounted, factory wired control panel
- Lo-hi-lo firing (7 thru 12 sections)

### Power Flame Gas and Oil Burners

- Two stage firing with fuel-air control
- Lo-hi-lo firing
- Modulating firing
- I.R.I., FM, MASS approval
- Other motor current characteristics
- Increased gas train sizes for low pressure drops
- Flame safeguard options

Burner Models										
No. of Boiler Sections	Carlin Oil	HP	Beckett Oil	HP	Power Flame					
					Oil	HP	Gas	HP	Gas/Oil	HP
3	201CRD	—	CF500	1/3	—	—	JR15A	1/4	—	—
4	301CRD	1/4	CF500	1/3	CR1-0	1/3	JR15A	1/4	CR1-GO	1/3
5	301CRD	1/4	CF800	1/3	CR1-0	1/3	JR30A	1/4	CR1-GO	1/3
6	702CRD	1/2	CF1400	1/2	CR1-0	1/2	JR30A	1/3	CR1-GO	1/3
7	702CRD	1/2	CF1400	1/2	CR2-0	3/4	JR30A	1/3	CR2-GO	3/4
8	702CRD	1/2	N/A	N/A	CR2-0	3/4	JR50A	1/3	CR2-GO	3/4
9	702CRD	1/2	CF2300	3/4	CR2-0	3/4	JR50A	1/3	CR2-GO	3/4
10	801CRD	3/4	CF2300	3/4	CR2-0	3/4	JR50A	1/3	CR2-GO	3/4
11	801CRD	3/4	CF2500	2	CR2-0	1	CR2G	1/2	CR2-GO	3/4
12	801CRD	3/4	CF2500	2	CR2-0	1 1/2	CR2G	1/2	CR2-GO	3/4



MEA #416-99-M

In the interest of product development, we reserve the right to make changes without notice.

**Smith**  
CAST IRON BOILERS

Westcast, Inc., 260 North Elm Street, Westfield, MA 01085  
(413) 562-9631 • FAX: (413) 562-3799  
www.smithboiler.com

◆ A MESTEK COMPANY



Log on to [www.smithboiler.com](http://www.smithboiler.com) and get connected to the Smith Heating Pros SPECifier. Fast, browser-based, easy-to-use program provides dynamically generated specifications, Auto-Cad drawings and more for Smith commercial boilers.