

PRODUCT DATA

 **Smith Water Boilers [RTS HE Series]**
 High Efficiency Pressurized Wet Base
 Water Boiler/Burner Unit



Designed to provide the highest efficiencies possible with forced draft firing. This new product line of Smith cast iron boilers is available in fifteen basic sizes, with gross output ratings from 931 to 4,622 MBH. RTS HE Series boilers are used in water systems, and may be fired with light oil, gas or gas/light oil.

STANDARD FEATURES

- Up to 85.8% thermal efficiencies
- Return temperature stabilizer (RTS)
- Cast iron wet base sections tested for 80 psi water working pressure
- Insulated metal jacket (R11.7)
- Burner mounting plate with insulation block
- Front and rear flame observation ports
- Steel angle floor rails
- Heat Transfer Rods
- Ceramic fiber rope seal between sections
- Graphite port connectors
- Flue brush
- Manual reset hi-limit
- Operating control

ADDITIONAL FEATURES FOR WATER BOILERS

- A.S.M.E. relief valve, 40 psi
- Theraltimer



I B R Ratings, Burner Capacities

Designed and tested to the A.S.M.E. boiler and pressure vessel code, section IV for maximum allowable working pressure, water 80 PSIG.

Boiler Number (Note 1)	Boiler Horsepower	I=B=R Gross Output (MBH)	Net I=B=R Ratings (Note 2)			Heating Surface (Sq. Ft.)	Furnace Volume (Cu. Ft.)	Water Contents (Gals.)	Water Working Weight (Lbs.)	Thermal Efficiency		Combustion Efficiency	
			Water	I=B=R Burner Capacity						Oil	Gas	Oil	Gas
				MBH	Oil GPH (Note 3)			Gas MBH (Note 4)	Water				
†RTS/28HE-4	27	931	810	7.9	1143	81.2	12.04	123.4	4215	83.9	81.4	86.2	83.6
†RTS/28HE-5	35	1194	1038	10.2	1458	105.3	16.14	150.3	5038	84.4	81.9	86.2	83.6
†RTS/28HE-6	43	1458	1268	12.2	1773	129.4	20.24	177.2	5861	84.8	82.2	86.1	83.5
†RTS/28HE-7	51	1722	1497	14.4	2088	153.5	24.34	204.1	6684	85.0	82.5	86.1	83.5
†RTS/28HE-8	59	1985	1726	16.6	2403	177.6	28.44	231.0	7507	85.2	82.6	86.1	83.5
†RTS/28HE-9	67	2249	1956	18.8	2718	201.7	32.54	257.9	8331	85.3	82.7	86.1	83.5
†RTS/28HE-10	75	2513	2185	21.0	3033	225.8	36.64	284.8	9169	85.4	82.8	86.1	83.5
†RTS/28HE-11	83	2776	2414	23.0	3348	249.9	40.74	311.7	9992	85.5	82.9	86.0	83.5
†RTS/28HE-12	91	3040	2643	25.5	3663	274.0	44.84	338.6	10,815	85.6	83.0	86.0	83.5
†RTS/28HE-13	98	3304	2873	27.5	3978	289.1	48.94	365.5	11,649	85.6	83.0	86.0	83.5
†RTS/28HE-14	106	3567	3102	29.5	4293	322.2	53.04	392.4	12,467	85.7	83.1	86.0	83.5
†RTS/28HE-15	114	3831	3331	32.0	4608	346.3	57.14	419.3	13,511	85.7	83.1	86.0	83.4
†RTS/28HE-16	122	4095	3561	34.0	4923	370.4	61.24	446.2	14,375	85.7	83.2	86.0	83.4
†RTS/28HE-17	130	4358	3790	36.5	5238	394.5	65.34	473.1	15,239	85.8	83.2	86.0	83.4
†RTS/28HE-18	138	4622	4019	38.5	5553	418.6	69.44	500.0	16,103	85.8	83.2	86.0	83.4

(Note 1) Important Ordering information

(†) Add Prefix for type of fuel to be burned. "LO" for light oil, "G" for Gas or "GO" for gas/oil.

Example: LO-RTS/28HE-6 is the model no. for a six section water boiler firing light oil.

(Note 2) Net I=B=R Water Ratings are based on an allowance of 1.15.

(Note 3) Light oil having a heat content of 140,000 BTU/Gal.

(Note 4) Gas having a heat content of 1,000 BTU/Cu. Ft., 0.60 specific gravity.

RTS HE Series

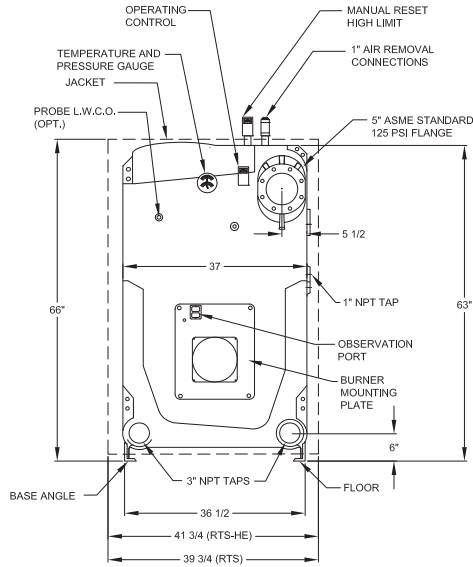

SIOM-94 R-1

FRONT VIEW (Water Boiler)

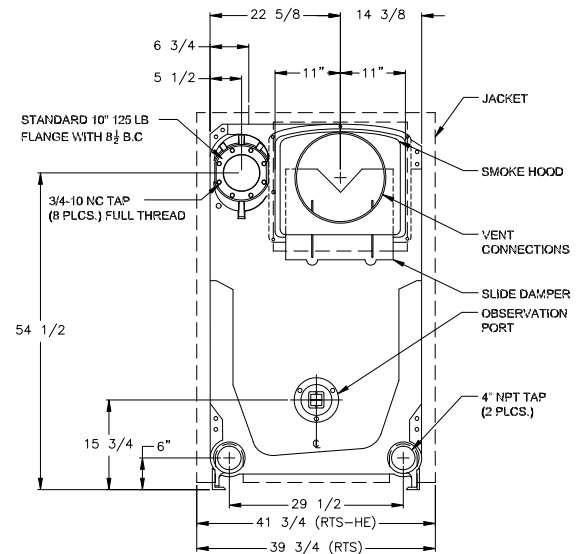

SIOM-97

REAR VIEW

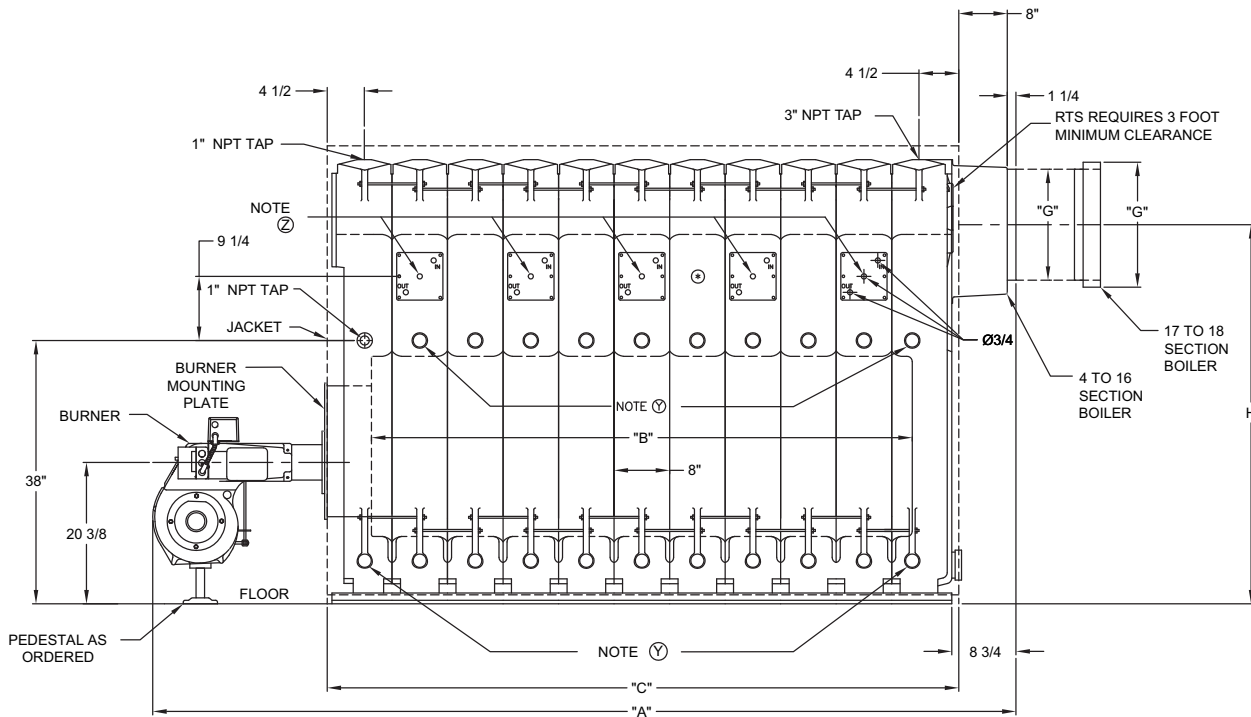

SIOM-96

SIDE VIEW

(Note Y) 1-1/2" inspection tappings when ordered.

(Note Z) Tankless heater sections when ordered. Allow 36" clear space for heater withdrawal.

Dimensions (inches)

Boiler Number (Note 1)	Overall Length — "A"			Opt. Packaged Base Dimensions				Furnace Length "B"	Boiler Length "C"	Draft Loss Ins. W.C.	Firebox Press Ins. W.C.††	Dia. Vent Conn. "G"	(Note 7) Height Vent Conn. "H"
	(Note 8)			Carlin & Beckett		Power Flame							
	Carlin	Beckett	Power Flame	"J"	"K"	"J"	"K"						
†RTS/28HE-4	62¼	64	71¾	54¼	83¼	54¼	91¼	23½	33	.40	.50	10	57%
†RTS/28HE-5	70¼	72	83¾	62¼	91¼	62¼	104¼	31½	41	.42	.52	10	57%
†RTS/28HE-6	80¾	80¼	91¾	70¾	99¾	70¾	112¾	39¾	49	.44	.54	10	57%
†RTS/28HE-7	88¾	88¾	99¾	78¾	107¾	78¾	120¾	47½	57	.46	.56	12	56%
†RTS/28HE-8	96¾	96¾	107¾	86½	115¼	86½	128½	55½	65	.48	.58	12	56%
†RTS/28HE-9	108¾	104¼	115¾	96½	123¼	94½	136½	63½	73	.52	.62	14	55%
†RTS/28HE-10	116¾	116¾	128	102¾	135¼	102¾	144¾	71½	81	.53	.63	14	55%
†RTS/28HE-11	125¾	124¾	137¾	110¾	143¼	110¾	157¾	79¾	89	.55	.65	14	55%
†RTS/28HE-12	133¾	132½	145¾	118¾	151¼	118¾	165¾	87¾	97	.57	.67	14	55%
†RTS/28HE-13	141¾	140½	153¾	126¾	159¼	126¾	173¾	95¾	105	.59	.69	14	55%
†RTS/28HE-14	—	—	161¾	—	—	134¾	181¾	103¾	113	.61	.71	16	54%
†RTS/28HE-15	—	—	169¾	—	—	142¾	189¾	111¾	121	.63	.73	16	54%
†RTS/28HE-16	—	—	177¾	—	—	150¾	198	119¾	129	.66	.76	16	54%
†RTS/28HE-17	—	—	191¾	—	—	159	206	127¾	137	.69	.79	18	54%
†RTS/28HE-18	—	—	199¾	—	—	167¾	214¾	135¾	145	.70	.80	18	54%

(Note) These measurements are approximate. The Smith representative should be consulted before selecting boilers for installation having unusual piping and pick-up requirements, such as intermittent system operation, extensive piping systems, etc. The boiler ratings have been determined under previous governing forced draft units.

(††) Based on 0.10 ins. W.C. pressure at boiler outlet. If vent sizing results in a back pressure greater than 0.10 ins. W.C., consult Smith.

(Note 7) When unit is assembled or packaged, add 6" to heights for 4-14 sect., 8" to heights for 15-18 sect.

(Note 8) Add 2-3/4" to sect. 17 and 18 for smoke hood adaptor.

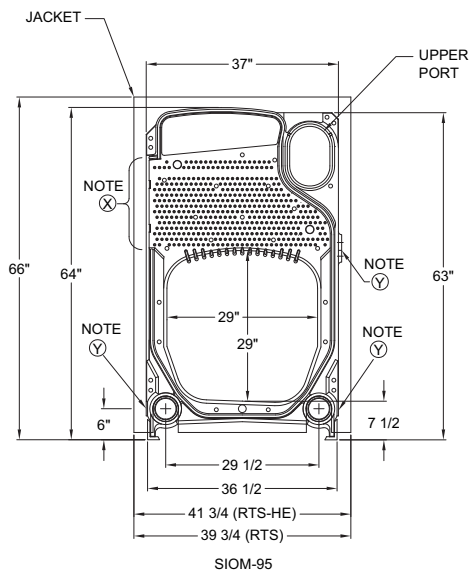

INTERMEDIATE VIEW

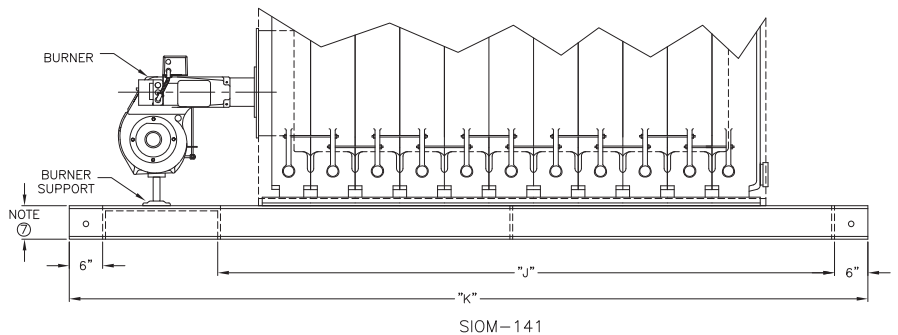

ASSEMBLY – SIDE VIEW

(Note X) Flue cleanout opening. Allow 36" clear work space for using flue brush, and for the removal of the heat transfer rods.

(Note Y) 1-1/2" inspection tappings when ordered.

Recommended Water Piping Diagram

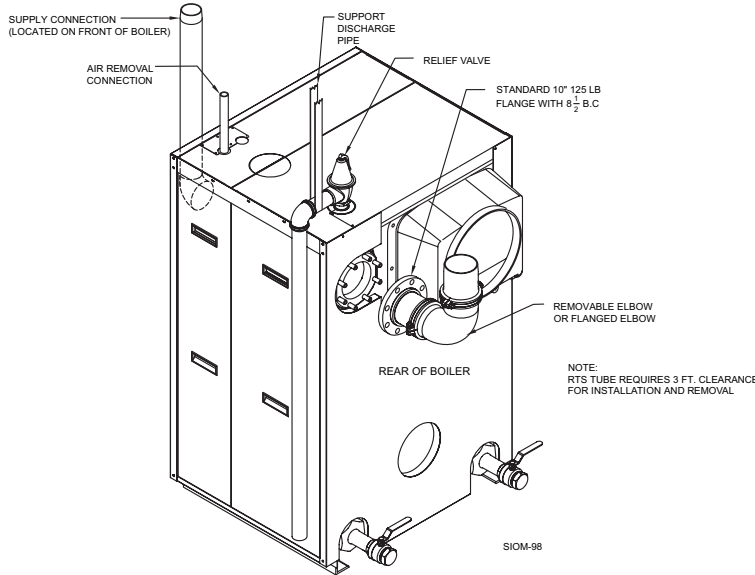

RTS HE Boiler Size	20°F Δ T Ø GPM	Return Connection	Supply Connection
RTS/28HE-4	90	3"	3"
RTS/28HE-5	116	3"	3"
RTS/28HE-6	143	4"	4"
RTS/28HE-7	169	4"	4"
RTS/28HE-8	196	4"	4"
RTS/28HE-9	223	4"	4"
RTS/28HE-10	249	5"	5"
RTS/28HE-11	276	5"	5"
RTS/28HE-12	303	5"	5"
RTS/28HE-13	329	5"	5"
RTS/28HE-14	356	5"	5"
RTS/28HE-15	383	5"	5"
RTS/28HE-16	409	5"	5"
RTS/28HE-17	436	5"	5"
RTS/28HE-18	462	5"	5"

Burner Specifications

Boiler Number	Burners - Light Oil						Burners - Gas		Burners - Gas/Oil	
	Carlin (Note 5)		Beckett (Note 5)		Power Flame (Note 6)		Power Flame (Note 6)		Power Flame (Note 6)	
	Model No.	H.P.	Model No.	H.P.	Model No.	H.P.	Model No.	H.P.	Model No.	H.P.
†RTS/28HE-4	702CRD	½	CF1400	½	C1-0	½	J50A-15	⅓	C1-G0-12	½
†RTS/28HE-5	702CRD	½	CF1400	½	C1-0	½	J50A-15	½	C1-G0-12	½
†RTS/28HE-6	801CRD	¾	CF2300	¾	C2-0A	1	J50A-15	½	C2-G0-15	1
†RTS/28HE-7	801CRD	¾	CF2300	¾	C2-0A	1	J50A-15	½	C2-G0-15	1
†RTS/28HE-8	801CRD	¾	CF2300	¾	C2-0B	1	C2-G-20A	¾	C2-G0-20A	1
†RTS/28HE-9	1050FFD	1	CF2300	¾	C2-0B	1½	C2-G-20B	1	C2-G0-20B	1½
†RTS/28HE-10	1050FFD	1	CF2500	2	C2-0B	1½	C2-G-20B	1	C2-G0-20B	1½
†RTS/28HE-11	1150FFD	1½	CF2500	2	C3-0	2	C3-G-20	1½	C3-G0-20	2
†RTS/28HE-12	1150FFD	1½	CF3500	2	C3-0	2	C3-G-25	1½	C3-G0-25	2
†RTS/28HE-13	1150FFD	1½	CF3500	2	C3-0	2	C3-G-25	1½	C3-G0-25	2
†RTS/28HE-14	—	—	—	—	C3-0	2	C3-G-25	1½	C3-G0-25	2
†RTS/28HE-15	—	—	—	—	C3-0B	3	C3-G-25B	3	C3-G0-25B	3
†RTS/28HE-16	—	—	—	—	C3-0B	3	C3-G-25B	3	C3-G0-25B	3
†RTS/28HE-17	—	—	—	—	C4-0A	5	C4-G-25	3	C4-G0-25	5
†RTS/28HE-18	—	—	—	—	C4-0A	5	C4-G-25	3	C4-G0-25	5

(Note 5) Burner operation: Low-High-Low (4-13 sect.).

(Note 6) Burner operation: Low-High-Low, (4-9 sect.); Modulation (10-18 sect.).

(†) Add Prefix for type of fuel to be burned. "LO" for light oil, "G" for Gas or "GO" for gas/oil.

Example: LO-RTS/28HE-6 is the model no. for a six section water boiler firing light oil.

Smith
CAST IRON BOILERS

WESTCAST, INC.
260 NORTH ELM STREET WESTFIELD, MA 01085
TEL. (413) 562-9631 FAX (413) 562-3799
www.smithboiler.com