



SPECTRUM FINNED COPPER GAS BOILERS (MODEL SB) & WATER HEATERS (MODEL SW) INSTALLATION & OPERATION MANUAL



DESIGNED AND TESTED ACCORDING TO A.S.M.E. BOILER AND PRESSURE VESSEL CODE, SECTION IV FOR A MAXIMUM ALLOWABLE WORKING PRESSURE OF 160 PSI, 1103 kPa WATER

WARNING: If the information in this manual is not followed exactly, a fire or explosion may result causing property damage, personal injury or loss of life.

Do not store or use gasoline or other flammable vapors and liquids in the vicinity of this or any other appliance.

WHAT TO DO IF YOU SMELL GAS:

- Do not try to light any appliance.
- Do not touch any electrical switch; do not use any phone in your building.
- Immediately call your gas supplier from a neighbor's phone. Follow the gas supplier's instructions.
- If you cannot reach your gas supplier, call the fire department.

Installation and service must be performed by a qualified installer, service agency or the gas supplier.

WARNING: Failure to properly vent this unit can cause excessive amounts of carbon monoxide resulting in severe personal injury or death!

INSTALLER, THESE INSTRUCTIONS TO BE AFFIXED ADJACENT TO THE HEATER.
CONSUMER, RETAIN THESE INSTRUCTIONS FOR FUTURE REFERENCE PURPOSES.



260 North Elm Street
Westfield, MA 01085
Phone: (413) 568-9571
Fax: (413) 568-9613

7555 Tranmere Drive
Mississauga, Ontario L5S 1L4
Phone: (905) 670-5888
Fax: (905) 670-5782



AVERTISSEMENT. Assurez-vous de bien suivre les instructions données dans cette notice pour réduire au minimum le risque d'incendie ou d'explosion ou pour éviter tout dommage matériel, toute blessure ou la mort

Ne pas entreposer ni utiliser d'essence ou ni d'autres vapeurs ou liquides inflammables à proximité de cet appareil ou de tout autre appareil.

QUE FAIRE SI VOUS SENTEZ UNE ODEUR DE GAZ:

- **Ne pas tenter d'allumer d'appareil.**
- **Ne touchez à aucun interrupteur; ne pas vous servir des téléphones se trouvant dans le bâtiment.**
- **Appelez immédiatement votre fournisseur de gaz depuis un voisin. Suivez les intructions du fournisseur.**
- **Si vous ne pouvez rejoindre le fournisseur, appelez le service des incendies.**

L'installation et l'entretien doivent être assurés par un installateur ou un service d'entretien qualifié ou par le fournisseur de gaz.

CONTENTS

Before Your Start.....	page 2
Ratings & Capacities	page 3
Boiler/Water Heater Location	page 3
Combustion Air & Ventilation	page 3
Chimney & Vent Pipe Connections	page 4
Common Vent Systems	page 5
Outdoor Venting	page 8
General Piping Requirements	page 8
Heating System Piping	page 9
Domestic Water Supply Piping	page 13
Gas Supply Piping	page 17
Electrical Wiring	page 18
General Operation	page 19
Lighting Instructions	page 20
Operating Instructions	page 21
Checking & Adjustments	page 22
Control Description	page 22
Maintenance	page 23
Repair Parts.....	page 25

BEFORE YOU START

This manual covers the application, installation, operation and maintenance of a Spectrum finned copper heating boiler/water heater/pool heater (Canada Only).

To obtain the safe, dependable, efficient operation and long life for which this heating boiler/water heater was designed, these instructions must be read, understood and followed.

The Spectrum finned copper heating boiler/water heaters have been design certified by CSA for use with natural and propane gas under the latest revision of ANSI-Z21.10.3/CSA 4.3, Gas Water Heaters, ANSI-Z21.13/CSA 4.9, Gas-Fired Low Pressure Steam and Hot Water Boilers and CAN-1-3.1, Industrial and Commercial Gas Fired Boilers. Each unit has been constructed and hydrostatically tested for a maximum working pressure of **160 psi, 1103 KPa** in accordance with Section IV of the A.S.M.E. Boiler and Pressure Vessel Code.

All aspects of the boiler/water heater installation must conform to the requirements of the authority having jurisdiction, or, in the absence of such requirements, to the National Fuel Gas Code, ANSI Z223.1/NFPA54-latest revision.

In Canada, the installation must be in accordance with the requirements of CAN/CGA B149.1 or .2, Installation Code for Gas Burning Appliances and Equipment.

If installed in the Commonwealth of Massachusetts, you **MUST FOLLOW** the additional instructions contained in RBI's instruction sheet MACODE-3. If you do not have a copy, call your RBI distributor or contact the RBI Customer Service Department.

The owner should maintain a record of all service work performed with the date and a description of the work done. Include the name of the service organization for future reference.

Direct all questions to your RBI distributor or contact the RBI Customer Service Department, 260 North Elm Street, Westfield, MA 01085 for U.S. or 7555 Tranmere Drive, Mississauga ONT L5S 1L4 for Canada. Always include the model and serial numbers from the rating plate of the boiler/water heater in question.

RATINGS & CAPACITIES

Before undertaking the installation of the Spectrum boiler/water heater check the rating plate to ensure that the unit has been sized properly for the job. The "Net I=B=R Ratings" specify the equivalent amount of direct cast iron radiation that the unit can supply under normal conditions. Also ensure that the unit has been set up for the type of gas available at the installation site. Other important considerations are the availability of an adequate electrical supply, fresh air for combustion and a suitable chimney or vent system.

BOILER/WATER HEATER LOCATION

1. This boiler/water heater is suitable for indoor and outdoor installations. Locate the boiler/water heater in an area that provides good access to the unit. Servicing may require the removal of jacket panels. Allow the minimum clearances between adjacent construction and the boiler/water heater as listed in Table 1.

NOTE: Service clearances are not mandatory, but are recommended to ensure ease of service should it be required.

Table 1

	Clearance to Combustibles		Service Clearance	
	in	mm	in	mm
Top	14	356	18	457
Back	6	152	18	457
Left Side	6	152	24	609
Right Side	6	152	24	609
Front	6	152	24	609
Flue	6	152	6	152

2. An optimum site will be level, central to the piping system, close to a chimney and have adequate fresh air for combustion. Ensure that the boiler/water heater is level from front to back and from side to side. Use metal shims to level the boiler/water heater. Electrical and electronic components must also be protected from exposure to water during operation and maintenance. DO NOT install this boiler/water heater in a location that would subject any of the gas ignition components to direct contact with water or excessive moisture during operation or servicing.
3. Ensure that the floor is structurally sound and will support the weight of the boiler/water heater.

NOTE: The Spectrum may be installed directly on combustible flooring, only if RBI supplied special floor pan is used but never on carpeting, see Table 2.

Table 2 - Special Base for Combustible Floors

Model Number	Part Number
100	70-1248
150	70-1249
200	70-1250
250	70-1251
300	70-1252
350	70-1253
400	70-1254

4. Locate the boiler/water heater in an area that will prevent water damage to adjacent construction should a leak occur or during routine maintenance. If such a location doesn't exist, a suitable drain pan that's adequately drained must be installed under the unit. The pan must not restrict the flow of combustion air to the unit.
5. DO NOT place this boiler/water heater in a location that would restrict the introduction of combustion air into the unit or subject it to a negative pressure, see "GENERAL VENTING GUIDELINES".
6. NEVER place this boiler/water heater in a location that would subject it to temperatures at or near freezing. See the "Freeze Protection" section on page 8.

WARNING: Never store combustible materials, gasoline or any product containing flammable vapors or liquids in the vicinity of the boiler/water heater. Failure to comply with this warning can result in an explosion or fire causing extensive property damage, severe personal injury or death!

CAUTION: Units installed outdoors MUST be protected from ice and snow accumulation or the unit will be damaged voiding the warranty!

COMBUSTION AIR & VENTILATION

WARNING: This boiler/water heater must be supplied with combustion air in accordance with Section 5.3, Air for Combustion & Ventilation, of the latest revision of the National Fuel Gas Code, ANSI Z223.1/NFPA 54 and all applicable local building codes. Canadian installations must comply with CSA B149.1 or .2 Installation Code for Gas Burning Appliances and Equipment, or applicable provisions of the local building codes. Failure to provide adequate combustion air for this boiler/water heater can result in excessive levels of carbon monoxide that can result in severe personal injury or death!

To operate properly and safely this boiler/water heater requires a continuous supply of air for combustion. NEVER store objects on or around the boiler/water heater!

CAUTION: Combustion air contaminated with fluorocarbons or other halogenated compounds such as cleaning solvents and refrigerants will result in the formation of acids in the combustion chamber. These acids will cause premature failure of the boiler/water heater voiding the warranty!

CAUTION: If the boiler/water heater is operated while the building is under construction it MUST be protected from wood, concrete, sheet rock and other types of dust. Failure to properly protect the unit from construction dust will damage the unit voiding the warranty!

All Air From Inside The Building

If the boiler/water heater is to be located in a confined space, minimum clearances listed in Table 1 must be maintained between the boiler/water heater and any combustible construction. When installed in a confined space, Figures 1 and 2, two permanent openings communicating with an additional room(s) are required. The combined volume of these spaces must have sufficient volume to meet the criteria for an unconfined space. The total air requirements of all gas utilization equipment, fireplaces, wood stoves or any type of exhaust fan must be considered when making this determination. Each opening must have a minimum free area of **1 in²/1000 Btu/hr, 2200 mm²/kW** based on the total input rating of ALL gas utilization equipment in the confined area. Each opening must be no less than **100 in², 64,516 mm²** in size. The upper opening must be within **12 in, 305 mm** of, but not less than **3 in, 76 mm** from, the top of the enclosure. The bottom opening must be within **12 in, 305 mm** of, but not less than **3 in, 76 mm** from, the bottom of the enclosure.

All Air From Outside The Building

When installed in a confined space two permanent openings communicating directly with, or by ducts to, the outdoors or spaces that freely communicate with the outdoors must be present. The upper opening must be within **12 in, 305 mm** of, but not less than **3 in, 76 mm** from, the top of the enclosure. The bottom opening must be within **12 in, 305 mm** of, but not less than **3 in, 76 mm** from, the bottom of the enclosure.

Where directly communicating with the outdoors or communicating with the outdoors through vertical ducts, each opening shall have a minimum free area of **1 in²/4000 Btu/hr, 550 mm²/kW** of the total input rating of all of the equipment in the enclosure.

Where communicating with the outdoors through horizontal ducts, each opening shall have a minimum free area of **1 in²/2000 Btu/hr, 1100 mm²/kW** of the total input rating of all of the equipment in the enclosure.

When louvers and screens are used, they must have the same cross-sectional area as the free area of the opening to which they connect.

When calculating the free area necessary to meet the make-up air requirements of the enclosure, consideration must be given to the blockage effects of louvers, grills and screens. Screens must have a minimum mesh size of **1/4 in, 6.4mm**. If the free area through a louver or grill is not known, ducts should be sized per Table 3.

Canadian installations must comply with CSA B149.1 when **air supply** is provided by natural air flow from the outdoors for **natural draft**, partial fan-assisted, fan-assisted, or power draft-assisted **burners**, there shall be a permanent **air supply** opening(s) having a cross-sectional area of not less than **1 in² per 7,000 Btuh (310 mm² per kW)** up to **and including 1 million Btuh, plus 1 in² per 14,000 Btuh (155 mm² per kW) in excess of 1 million Btuh.**

Table 3 - Make-up Air Louver Sizing

Input (MBH)	Required Cross Sectional Area					
	1/4 in 6.4 mm Wire Screen		75% Free Area Metal Louvers		25% Free Area Wooden Louvers	
	in ²	cm ²	in ²	cm ²	in ²	cm ²
100	25	161	33	213	100	645
150	37	858	50	322	150	967
200	50	322	67	432	200	1290
250	62	400	83	535	250	1612
300	75	484	100	645	300	1934
350	87	561	117	754	350	2257
400	100	645	133	858	400	2579

CHIMNEY & VENT PIPE CONNECTIONS

WARNING: The vent installation must be in accordance with Part 7, Venting of Equipment, of the latest revision of the National Fuel Gas Code, ANSI Z223.1/NFPA 54 or applicable provisions of the local building codes. Canadian installations must comply with CSA B149.1 or .2 Installation Code. Improper venting can result in excessive levels of carbon monoxide which can result in severe personal injury or death!

Chimney Inspection & Sizing

A thorough inspection of the masonry chimney must be performed to ensure that the chimney is clean, properly constructed, lined and sized. Exterior masonry chimneys should not be used unless properly lined to prevent condensation and draft problems. Table 4 lists the equivalent breeching and flue sizes required for the boiler/water heater.

Table 4 - Equivalent Breeching & Chimney Size

Model Size	Size in	Size mm
100	5	127
150	6	152
200	7	178
250	8	203
300	8	203
350	9	229
400	10	254

Note: These sizes are based on a **20 ft, 6.1 m** chimney height.

When more than one appliance is connected to the same chimney flue, the flue must be large enough to safely vent the combined output of all the appliances.

WARNING: If an appliance using any type of a mechanical draft system operating under positive pressure is connected to a chimney flue, never connect any other appliances to this flue. Doing so can result in the accumulation of carbon monoxide which can cause severe personal injury or death!

Vent Connections

Always use a type B or single wall galvanized metal vent pipe the same diameter as the draft hood flue collar, Table 4. Use the shortest, straightest vent system possible for the installation. If horizontal runs exceed **6 ft, 1.8 m** they must be supported at **6 ft, 1.8 m** intervals with overhead hangers. The vent system should be sloped up toward the chimney at a minimum rate of **1/4 in/ft, 20 mm/m** and terminate flush with the inside of the chimney flue. Fasten each connection with at least 3 corrosion resistant sheet metal screws.

WARNING: Never modify or alter any part of the boiler's draft hood. This includes the removal or alteration of any baffles. Never install a vent pipe of a diameter different than that of the boiler draft hood flue collar. Failure to comply with this warning can result in severe personal injury or death!

Always provide a minimum clearance of **6 in, 152 mm** between type C vent pipe and any combustible materials. Type B1 vent may be used, clearance between it and any combustible material must be as listed.

WARNING: Failure to maintain minimum clearances between vent connectors and any combustible material can result in a fire causing extensive property damage, severe personal injury or death!

To determine the appropriate power venter for the boiler/water heater, see Table 5, Power Venter Sizes. Follow the power venter manufacturer's installation instructions.

Table 5 - Power Venter Sizes

Spectrum Model	Power Venter Size	Max. Pipe Length	
		FT	m
100-250	HS-1	100	31
300-400	HS-2	100	31

COMMON VENT SYSTEMS

If an existing boiler/water heater is removed from a common venting system, the common venting system may then be too large for the proper venting of the remaining appliances connected to it. At the time of removal of an existing boiler/water heater, the following steps shall be followed with each appliance remaining connected to the common venting system placed in operation, while the other appliances remaining connected to the common venting system are not in operation.

Au moment du retrait d'une chaudière existante, les mesures suivantes doivent être prises pour chaque appareil toujours raccordé au système d'évacuation commun et qui fonctionne alors que d'autres appareils toujours raccordés au système d'évacuation ne fonctionnent pas: système d'évacuation.

- a) Seal any unused openings in the common venting system.

Sceller toutes les ouvertures non utilisées du système d'évacuation.

- b) Visually inspect the venting system for proper size and horizontal pitch and determine there is no blockage or restriction, leakage, corrosion and other deficiencies which could cause an unsafe condition.

Inspecter de façon visuelle le système d'évacuation pour déterminer la grosseur et l'inclinaison horizontale qui conviennent et s'assurer que le système est exempt d'obstruction, d'étranglement de fuite, de corrosion et autres défaillances qui pourraient présenter des risques.

- c) Insofar as is practical, close all building doors and windows and all doors between the space in which the appliances remaining connected to the common venting system are located and other spaces of the building. Turn on clothes dryers and any appliance not connected to the common venting system. Turn on any exhaust fans, such as range hoods and bathroom exhaust, so they will operate at maximum speed. Do not operate a summer exhaust fan for a boiler installation. Close fireplace dampers.

Dans la mesure du possible, fermer toutes les portes et les fenêtres du bâtiment et toutes les portes entre l'espace où les appareils toujours raccordés du système d'évacuation sont installés et les autres espaces du bâtiment. Mettre en marche les sècheuses, tous les appareils non raccordés au système d'évacuation commun et tous les ventilateurs d'extraction comme les hottes de cuisinière et les ventilateurs des salles de bain. S'assurer que ces ventilateurs fonctionnent à la vitesse maximale. Ne pas faire fonctionner les ventilateurs d'été. Fermer les registres des cheminées.

- d) Place in operation the appliance being inspected. Follow the lighting instructions. Adjust thermostat so appliance will operate continuously.

Mettre l'appareil inspecté en marche. Suivre les instructions d'allumage. Régler le thermostat de façon que l'appareil fonctionne de façon continue.

- e) Test for spillage at the draft hood relief opening after 5 minutes of main burner operation. Use the flame of a match or candle, or smoke from a cigarette, cigar or pipe.

Faire fonctionner le brûleur principal pendant 5 min ensuite, déterminer si le coupe-tirage déborde à l'ouverture de décharge. Utiliser la flamme d'une allumette ou d'une chandelle ou la fumée d'une cigarette, d'un cigare ou d'une pipe.

- f) After it has been determined that each appliance remaining connected to the common venting system properly vents when tested as outlined above, return doors, windows, exhaust fans, fireplace dampers and any other gas-burning appliance to their previous condition of use.

Une fois qu'il a été déterminé, selon la méthode indiquée ci-dessus, que chaque appareil raccordé au système d'évacuation est mis à l'air libre de façon adéquate. Remettre les portes et les fenêtres, les ventilateurs, les registres de cheminées et les appareils au gaz à leur position originale.

- g) Any improper operation of the common venting system should be corrected so the installation conforms with the National Fuel Gas Code, ANSI Z223.1/NFPA 54. When resizing any portion of the common venting system, the common venting system should be resized to approach the minimum size as determined using the appropriate tables in Part 11 in the National Fuel Gas Code, ANSI Z223.1/NFPA 54 and or CAN/CGA B149 Installation Codes.

Tout mauvais fonctionnement du système d'évacuation commun devrait être corrigé de façon que l'installation soit conforme au National Fuel Gas Code, ANSI Z223.1/NFPA 54 et (ou) aux codes d'installation CAN/CGA-B149. Si la grosseur d'une section du système d'évacuation doit être modifiée, le système devrait être modifié pour.

Figure 1 - Vertical Venting with a Metal Chimney System and Inside Air

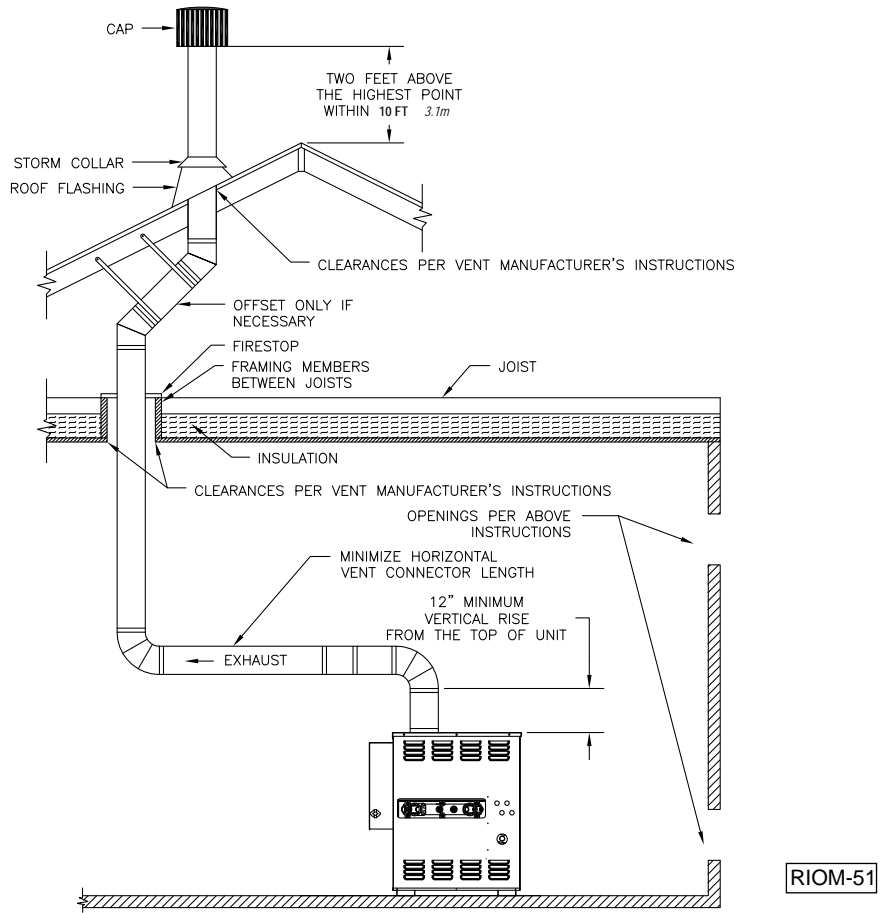
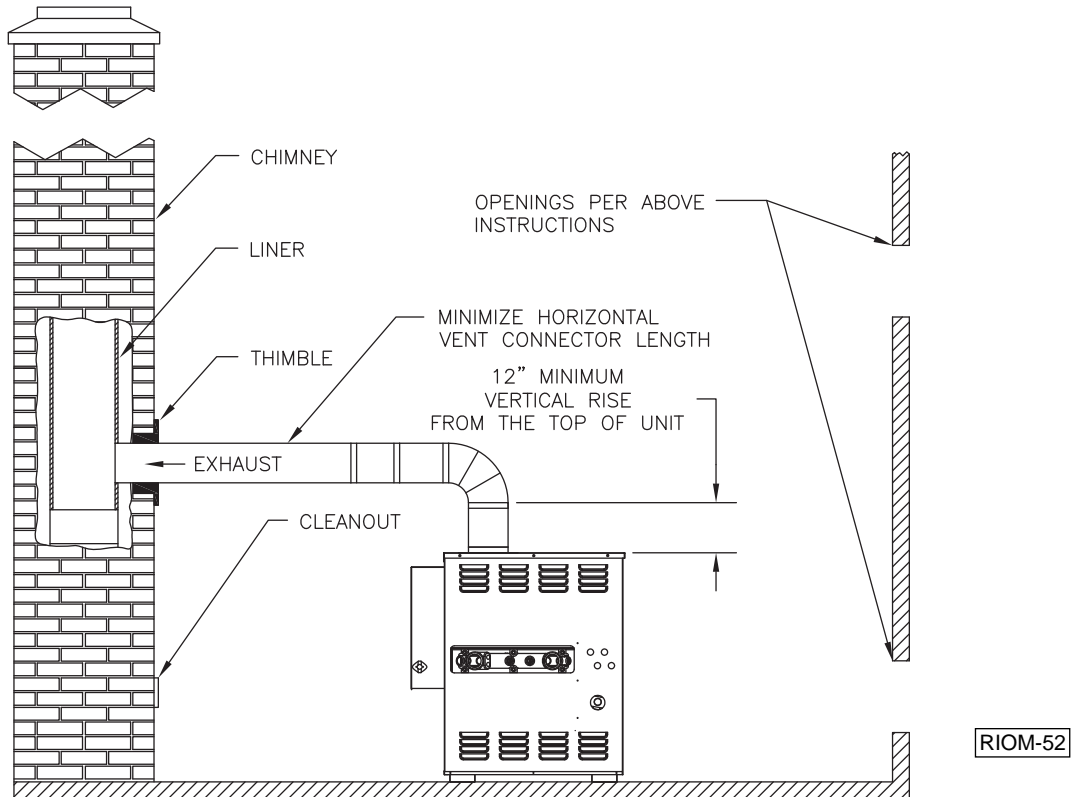

Figure 2 - Vertical Venting using a Masonry Chimney and Inside Air



OUTDOOR VENTING

When installed outdoors the Spectrum must be fitted with the factory supplied outdoor hood assembly, see Figure 3. Multiple units must be spaced per Figure 3A.

The boiler/water heater must be at least **10 ft, 3.1 m** from any door, window or gravity air inlet into any building and at least **3 ft, 0.9 m** from any overhang unless local codes dictate differently.

Avoid locations where wind deflection off of adjacent walls, buildings or shrubbery might cause a down draft. The unit(s) should be located at least **3 ft, 0.9 m** from structures. Outdoor installations are not recommended in areas where the danger of snow blockage exists.

CAUTION: Do not place the boiler/water heater in a location that would subject it to runoff from adjacent buildings or damage may occur voiding the warranty!

Figure 3 - Outdoor Venting

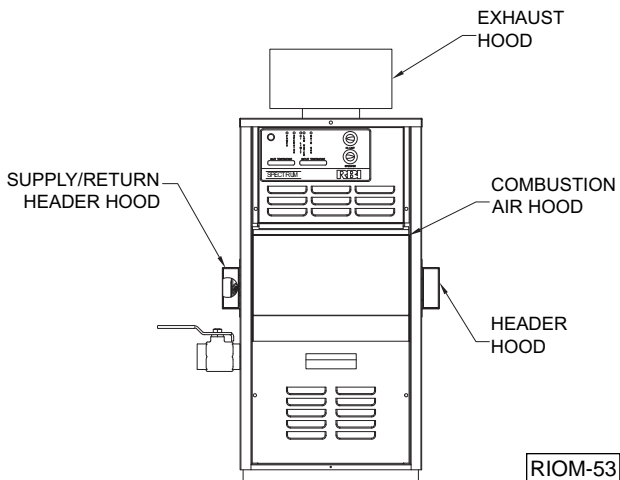
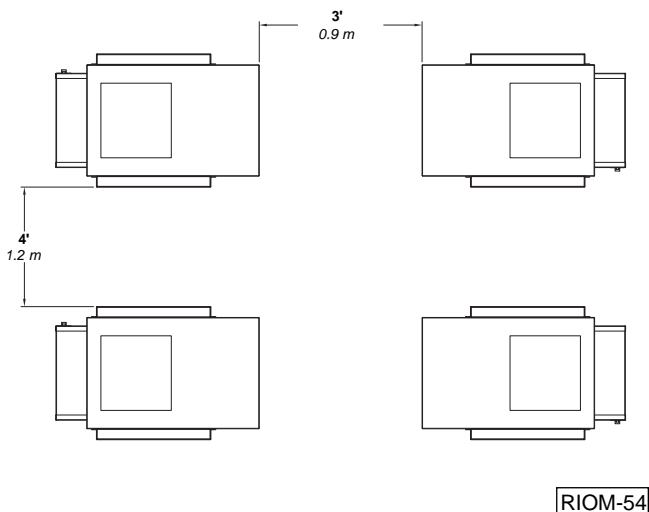

Figure 3A -Multiple Outdoor Units



GENERAL PIPING REQUIREMENTS

CAUTION: Improper piping of this boiler/water heater will void the manufacturer’s warranty and can cause boiler failure resulting in flooding and extensive property damage! Excessive water hardness causing lime build-up in the copper heat exchanger tubes is NOT covered under the manufacturer’s warranty. Excessive pitting and erosion of the internal surface of the copper heat exchanger tubes is NOT covered under the manufacturer’s warranty if the result of high water flow rates, see Table 7 or 8. Return water temperatures below 110°F, 43°C will result in heat exchanger damage from excessive condensation voiding the manufacturer’s warranty, see Primary/Secondary Piping Figure 5.

NOTE: Shut off valves and unions should be installed at the inlet and outlet connections of the boiler water heater to provide for isolation of the unit should servicing be necessary.

Freeze Protection

This boiler/water heater is CSA designed certified for outdoor installation. Outdoor installations in areas where the danger of freezing exists are not recommended unless proper freeze protection is provided. If the unit is to be installed in such an area the following precautions MUST be observed:

1. A continuous flow of water through the boiler/water heater MUST be maintained! The pump responsible for flow through the boiler/water heater must run continuously!
2. An ethylene glycol/water mixture suitable for the minimum temperature that the unit will be exposed to must be used. The pump must be capable of producing 15% more flow and overcoming a 20% increase in head loss. Domestic water systems must be isolated from the water heater by the use of a heat exchanger or other approved method.
3. If the boiler/water heater must be shut off for any reason the electric, gas and water supplies MUST be shut off and the unit and its pump completely drained.

CAUTION: Improper outdoor installation of this boiler/water heater can cause boiler failure voiding the manufacturer's warranty!

Relief Valve

Pipe the discharge of the pressure relief valve to prevent scalding in the event of a discharge, see Figure 4. The discharge piping must be sized the same as the pressure relief valve outlet and installed to allow complete drainage of both the relief valve and the discharge piping.

Figure 4

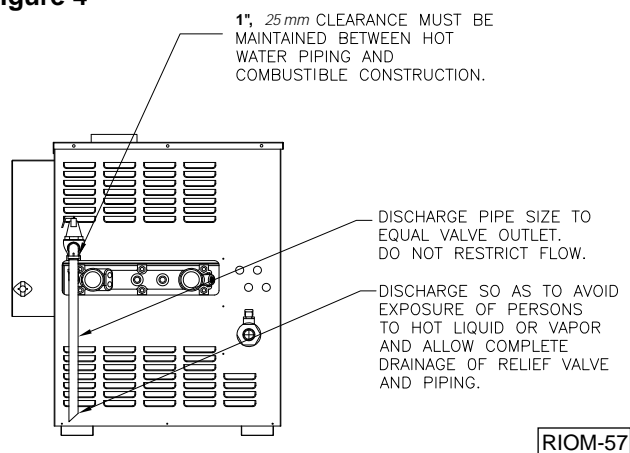

WARNING: Never install any type of valve between the boiler/water heater and the relief valve or an explosion causing extensive property damage, severe personal injury or death may occur!

Flow Switch

The flow switch supplied with the boiler/water heater must be wired to the terminal strip in the control panel to prevent the boiler from firing unless there's adequate water flow through the unit. The flow switch must be installed in the supply piping adjacent to the boiler outlet connection.

CAUTION: Failure to properly install the flow switch may result in damage to the boiler/water heater heat exchanger voiding the warranty!

HEATING SYSTEM PIPING

General Piping Requirements

All heating system piping must be installed by a qualified technician in accordance with the latest revision of the ANSI/ASME Boiler and Pressure Vessel Code, Section IV, and ANSI/ASME CSD-1, Standard for Controls and Safety Devices for Automatically Fired Boilers. All applicable local codes and ordinances must also be followed. A minimum clearance of **1 in, 25 mm** must be maintained between heating system pipes and all combustible construction. All heating system piping must be supported by suitable hangers not the boiler.

The thermal expansion of the system must be considered when supporting the system. A minimum system pressure of **12 psig, 82.7 kPa** must be maintained.

Heating Boiler Piping Connections

The supply and return connections should be sized to suit the system, see Table 6.

Table 6 - Supply & Return Pipe Sizing

Model Size	Supply	Return
100 thru 400	1½" NPT	1½" NPT

Pump Requirements

This low mass boiler requires a continuous minimum water flow for proper operation. The boiler pump must be sized to overcome the head loss of the boiler and the near piping in order to achieve the required temperature rise. Table 7 and 8 provides the heat exchanger pressure drop and temperature rise figures.

The temperature rise across the boiler must never exceed **30°F, 16.7 °C**. A pump delay is installed, the pump delay turns the pump on each time the burners fire and runs the pump up to 10 minutes after the call for heat is satisfied.

CAUTION: A temperature rise outside of the range listed in Tables 7 or 8 indicates that the flow rate through the heat exchanger is incorrect which will damage the heat exchanger voiding the warranty!

The maximum allowable flow rate through a Spectrum boiler with copper heat exchanger is 92 GPM, 5.8 L/s (2-pass heat exchanger) and 46 GPM, 2.9 L/s (4-pass heat exchanger).

Low Water Cutoff

If a boiler is installed above any radiation elements it must be fitted with a low water cutoff device.

Refer to wiring diagram supplied with the boiler/water heater for proper wiring connections.

Expansion Tank

An expansion tank or other means to control thermal expansion must be installed in the heating system. An expansion tank must be installed close to the boiler on the suction side of the system pump.

Primary/Secondary Piping

Boilers connected to heating systems using zone valves, zone pumps, or systems that have excessive flow rates or return water temperatures less than **110°F, 43 °C** must be isolated from these systems to protect the boiler.

Table 7 - Temperature Rise Table – 2 Pass Headers

Model Number	$\Delta T = 10^{\circ}\text{F}$		$\Delta T = 5.5^{\circ}\text{C}$		$\Delta T = 20^{\circ}\text{F}$		$\Delta T = 11.1^{\circ}\text{C}$		$\Delta T = 30^{\circ}\text{F}$		$\Delta T = 16.7^{\circ}\text{C}$	
	Flow Rate	Pres. Drop	Flow Rate	Pres. Drop	Flow Rate	Pres. Drop	Flow Rate	Pres. Drop	Flow Rate	Pres. Drop	Flow Rate	Pres. Drop
	GPM	Ft	L/s	kPa	GPM	Ft	L/s	kPa	GPM	Ft	L/s	kPa
100	16.4	0.05	1.0	0.1	—	—	—	—	—	—	—	—
150	24.6	0.13	1.6	0.4	—	—	—	—	—	—	—	—
200	32.4	0.27	2.0	0.8	16.2	0.07	1.0	0.2	—	—	—	—
250	40.5	0.48	2.6	1.4	20.3	0.13	1.3	0.4	—	—	—	—
300	49.8	0.82	3.1	2.4	24.9	0.23	1.6	0.7	16.6	0.10	1.0	0.3
350	58.1	1.23	3.7	3.6	29.1	0.34	1.8	1.0	19.4	0.20	1.2	0.5
400	66.4	1.77	4.2	5.2	33.2	0.49	2.1	1.4	22.1	0.20	1.4	0.7

Note: Unit equipped with 4 pass headers, see Table 8.

Table 8 - Temperature Rise Table – 4 Pass Headers

Model Number	$\Delta T = 10^{\circ}\text{F}$		$\Delta T = 5.5^{\circ}\text{C}$		$\Delta T = 20^{\circ}\text{F}$		$\Delta T = 11.1^{\circ}\text{C}$		$\Delta T = 30^{\circ}\text{F}$		$\Delta T = 16.7^{\circ}\text{C}$	
	Flow Rate	Pres. Drop	Flow Rate	Pres. Drop	Flow Rate	Pres. Drop	Flow Rate	Pres. Drop	Flow Rate	Pres. Drop	Flow Rate	Pres. Drop
	GPM	Ft	L/s	kPa	GPM	Ft	L/s	kPa	GPM	Ft	L/s	kPa
100	16.4	0.34	1.0	1.0	—	—	—	—	—	—	—	—
150	24.6	0.94	1.6	2.8	—	—	—	—	—	—	—	—
200	32.4	1.92	2.0	5.7	16.2	0.53	1.0	1.6	—	—	—	—
250	40.5	3.46	2.6	10.2	20.3	0.96	1.3	2.8	—	—	—	—
300	49.8*	5.89	3.1	17.3	24.9	1.63	1.6	4.8	16.6	0.80	1.0	2.3
350	See Note				29.1	2.47	1.8	7.3	19.4	1.20	1.2	3.4
400					33.2	3.54	2.1	10.4	22.1	1.70	1.4	4.9

Note: Unit equipped with 2 pass headers, see Table 7.

*Flow exceeds recommended maximum use a greater temperature rise or consult manufacturer. Cupro-nickel heat exchanger should be considered.

Figure 5 - Typical Primary/Secondary Piping System

(See Notes)

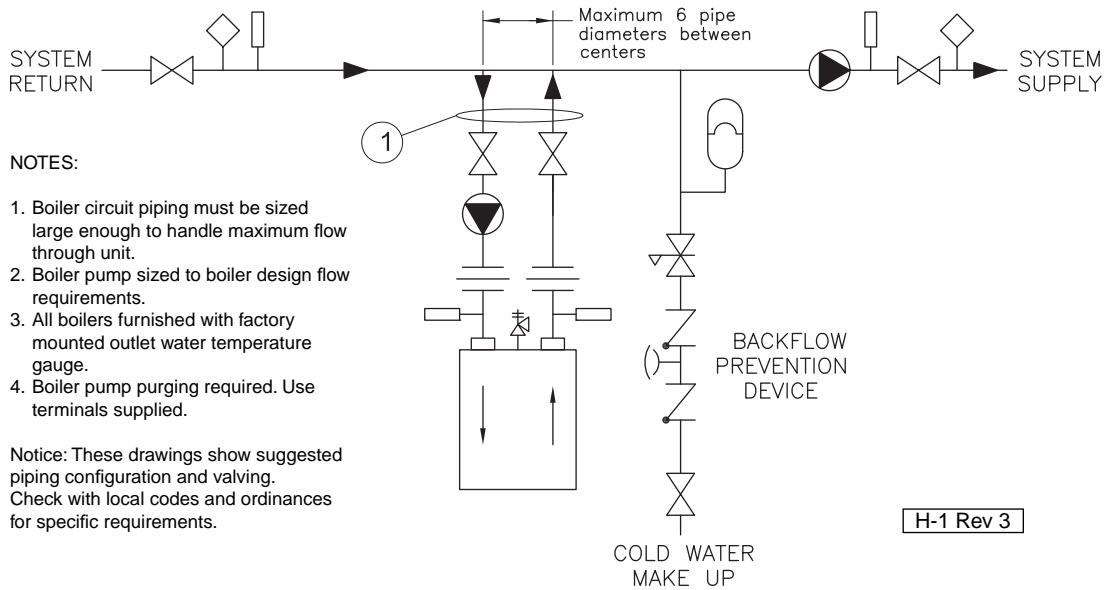
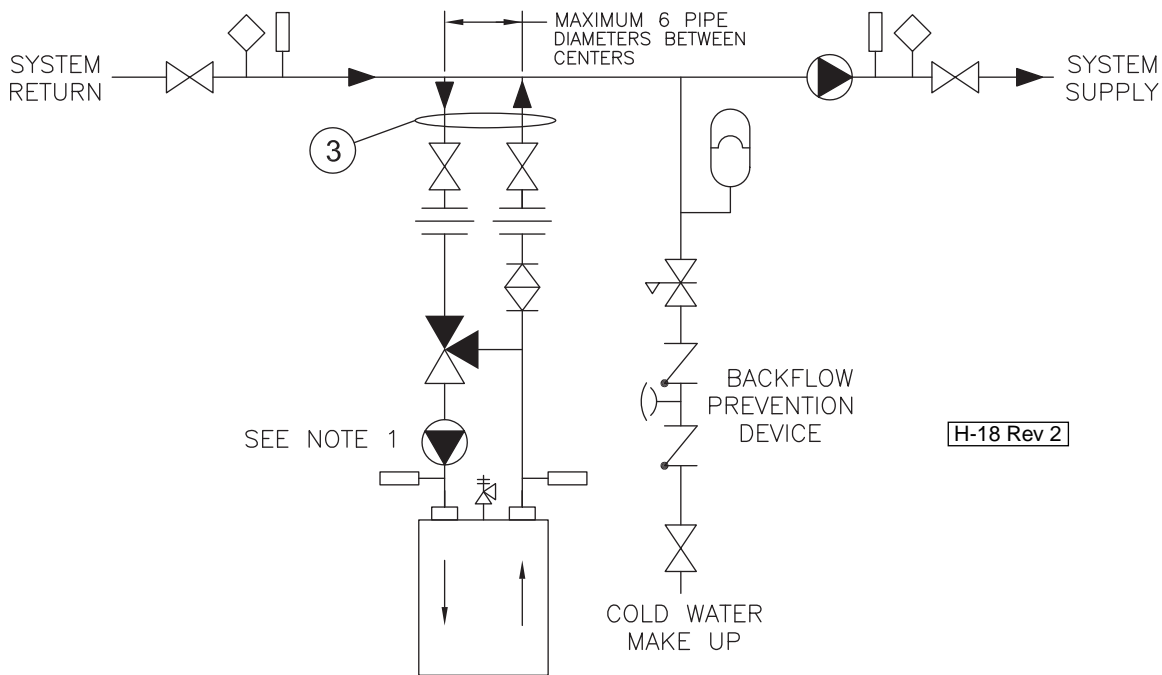

Figure 6 - Low Temperature Piping with Thermostatic Valve

(See Notes and Adjustment Procedures)



NOTES:

- For pump selection consult factory.
- Boiler pump sized to boiler and thermostatic 3-way valve design flow requirements.
- Boiler circuit piping must be sized large enough to handle maximum flow through unit.
- All boilers furnished with factory mounted outlet water temperature gauge.
- Boiler pump purging required. Use terminals supplied.
- Valve is precalibrated for 140°F return temperature.

Notice: These drawings show suggested piping configuration and valving. Check with local codes and ordinances for specific requirements.

	Pump
	Gate Valve
	Globe Valve
	Angle Valve
	Butterfly Valve
	Balance Valve
	Ball Valve
	Motorized Valve
	Solenoid Operated Valve
	Self-Operated Valve
	Pressure Reducing Valve
	Check Valve
	Pressure Relief Valve
	Flow Switch
	Thermometer
	Aquatstat Union
	Pressure Switch
	Gas Pressure Regulator
	Automatic Air Vent
	Backflow-Prevention Device
	3-Way Valve
	Expansion Tank

Figure 6A - Low Temperature Piping
(See Notes and Adjustment Procedures)

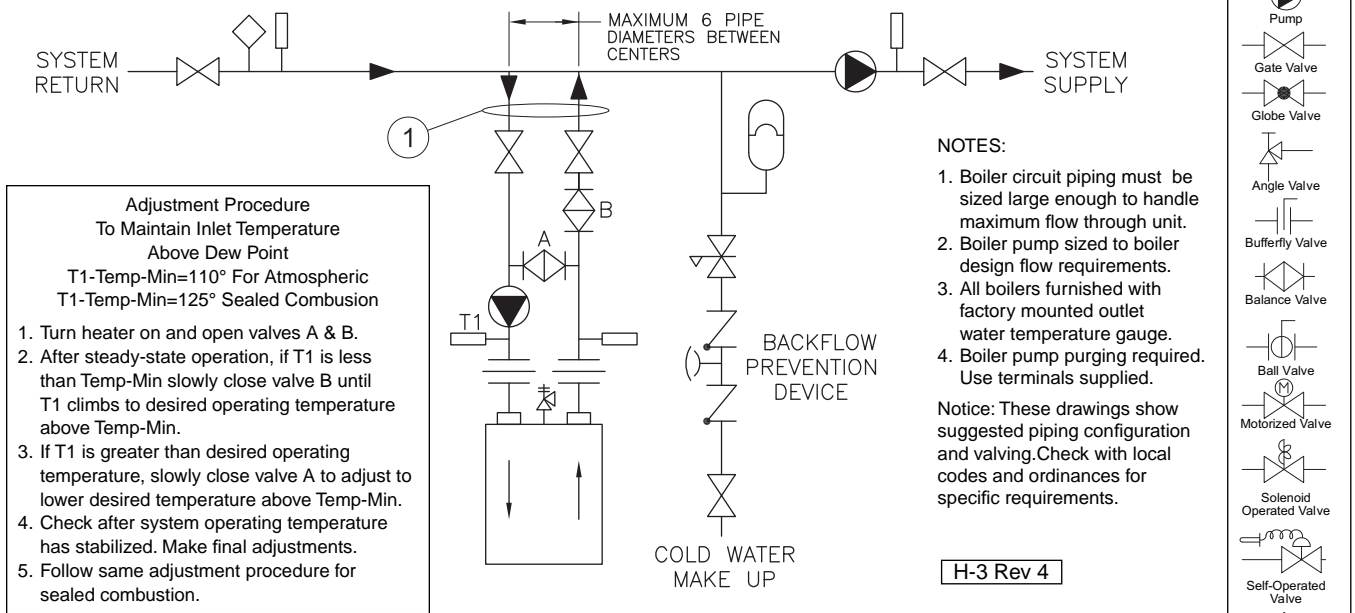
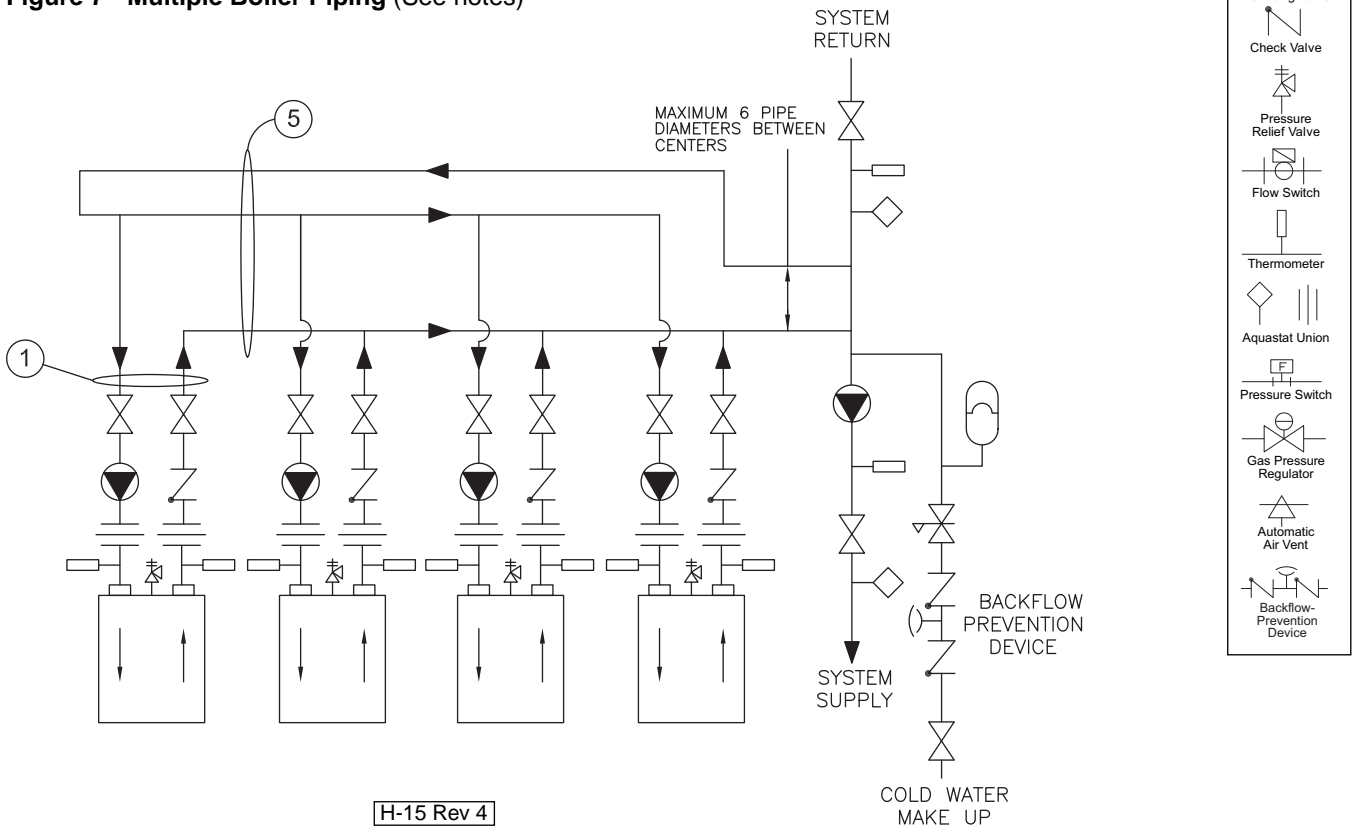

Figure 7 - Multiple Boiler Piping (See notes)



NOTES:

1. Boiler circuit piping must be large enough to handle maximum flow through unit.
2. Boiler pump sized to boiler design flow requirements.
3. All boilers furnished with factory mounted outlet water temperature gauge.
4. Boiler pump purging required. Use terminals supplied.
5. Secondary loop pipe diameter must be sized large enough to handle maximum flow through all units.

Notice: These drawings show suggested piping configuration and valving. Check with local codes and ordinances for specific requirements.

	Pump
	Gate Valve
	Globe Valve
	Angle Valve
	Butterfly Valve
	Balance Valve
	Ball Valve
	Motorized Valve
	Solenoid Operated Valve
	Self-Operated Valve
	Pressure Reducing Valve
	Check Valve
	Pressure Relief Valve
	Flow Switch
	Thermometer
	Aquastat Union
	Pressure Switch
	Gas Pressure Regulator
	Automatic Air Vent
	Backflow-Prevention Device

Variable Water Flows

Figure 5 shows a typical primary/secondary piping system. A dedicated pump is used to maintain a constant water flow through the boiler. This boiler pump is sized to overcome the head loss of the boiler and near piping while supplying the flow rate required to maintain the desired temperature rise across the boiler heat exchanger. The system pump is sized to provide the required flow to the heating system. The boiler piping connections to the heating system piping must not be more than **12 in, 305 mm** apart to ensure zero pressure drop, see Figure 5.

Low Return Water Temperatures

To prevent the problems associated with condensation of the products of combustion due to low return water temperatures a primary/secondary piping system with a bypass and bypass valve must be installed, see Figures 6 and 6A. The bypass and bypass valve must be sized the same as the secondary piping. A balancing valve must also be installed in the supply side of the secondary piping downstream of the bypass. The balancing valve should be adjusted to divert some of the heated discharge water into the return water until the required inlet water temperature is achieved. The primary and secondary pumps should be sized to provide the required flow through each system. The boiler piping connections to the heating system piping must not be more than **12 in, 305 mm** apart to ensure zero pressure drop, see Figures 6 and 6A.

Multiple Boiler Systems

Systems using multiple boilers can also be installed using a primary/secondary manifold system, Figure 7.

Piping For Use With Cooling Units

The boiler, when used in connection with a refrigeration system, must be installed so the chilled medium is piped in parallel with the boiler. Appropriate valves must be used to prevent the chilled water from entering the boiler.

When a boiler is connected to a heating coil that may be exposed to refrigerated air from an air handling device, the piping system must be equipped with flow-control valves or some other automatic means of preventing gravity circulation of the boiler water during the cooling cycle.

DOMESTIC WATER SUPPLY PIPING

CAUTION: Proper controls must be used to prevent water supplied for domestic use from exceeding 130°F, 54°C or a scald injury will occur! When higher water temperatures are required for appliances such as a dishwasher, a mixing valve or some other tempering means must be installed. Households with small children may require water temperatures less than 120°F, 49°C. Local codes must be complied with!

General Piping Requirements

Ensure that the water heater is equipped with bronze headers. Piping and components connected to the water heater must be suitable for use with potable water. The water heater must not be connected to any heating system piping or components previously used with a non-potable water heating appliance. No toxic chemicals, such as those used for boiler treatment, are to be introduced into any potable water used for space heating. If a hot water storage tank is used in the system, it must be equipped with a temperature and pressure relief valve that complies with ANSI Z21.22 or CAN-4.4 and CAN-4.6.

NOTE: The storage tank must be located as close to the water heater as possible to prevent excessive head loss which will reduce flow.

Water Chemistry

The required temperature rise across the water heater is based on water having a hardness between 5 and 25 grains per gallon with a level of dissolved solids not exceeding 350 ppm. Water having a hardness less than 5 grains can cause excessive corrosion of the heat exchanger. Water that has a hardness greater than 25 grains per gallon and/or a level of dissolved solids exceeding 350 ppm will require a recalculation of the pump size and temperature rise.

A cupro-nickel heat exchanger may also be required. The manufacturer should be consulted when these water conditions are encountered. See Table 9A.

RBI water heaters are designed to run scale free. Due to the extreme variables of water conditions world wide it is necessary to consider pH values and water hardness in relationship to scaling. It is crucial to consider these two variables when making heat exchanger and pump selections. If local water conditions are extreme follow the guidelines in the Heat Exchanger Selection Table (Table 9A) and the Pumping Performance Table (Table 9B). Scale free operation can be achieved by using water with a hardness between 8 and 18 and by maintaining the pH between 5 and 9. Follow the conditions listed under NORMAL in the table. In some areas of the country additional precautions must be observed due to unusual characteristics of the local water supply. Call the nearest RBI representative for details.

To properly size the pump a grain hardness and pH test must be taken at the installation site before the order is placed. Proper pump sizing will improve heater performance and help ensure heater longevity.

Expansion Tank

An expansion tank or other means to control thermal expansion must be installed in the water heating system if back flow prevention devices are installed.

Pump Requirements

This low-mass water heater requires a continuous minimum water flow for proper operation. The factory recommended circulating pump has been sized to overcome the head loss of the water heater plus a 30 foot piping loop under normal water conditions. Table 9B provides the heat exchanger pressure drop chart and temperature rise table. **The temperature rise across the water heater must never exceed 30°F, 16.7 °C.**

CAUTION: The maximum allowable flow rate through a Spectrum water heater is 92 GPM, 5.8 L/s (2-pass heat exchanger) and 46 GPM, 2.9 L/s (4-pass heat exchanger). The cupro-nickel heat exchanger allows for 100 GPM, 6.3 L/s (2-pass heat exchanger) and 50 GPM, 3.2 L/s (4-pass heat exchanger). See Table 9B.

Cold Water Supply

The cold water supply must be piped to the storage tank on the water heater's outlet piping between the water heater and the hot water storage tank. This will prevent untempered water from entering the water heater, see the Temperature Rise Control section. A typical water heating system is shown in Figures 8 and 9.

Temperature Rise Control

Water returned to the water heater inlet must not be less than **110°F, 43°C** or excessive condensation of the products of combustion will damage the water heater voiding the warranty. The method outlined below can be employed to prevent this condition from occurring.

A balancing valve should be installed on the outlet side of the water heater for purposes of adjusting the flow rate through the heat exchanger. Thermometers are installed on both the inlet and outlet of the water heater for determining the temperature rise through the unit.

The proper velocity through the water heater must be maintained in accordance with Table 9B for efficient operation and long life. If the temperature rise through the water heater is lower than recommended, the water velocity is too high. Premature erosion of the heat exchanger will occur. Conversely, if the temperature rise is higher than recommended in Table 9B the flow rate is too low. Scaling and softening of the heat exchanger will occur.

Thermostatic Mixing Valve - Water Above 140°F, 60°C

Water can be stored at temperatures above **140°F, 60 °C** provided that a thermostatically controlled mixing valve is used to temper the hot water to an acceptable temperature before it's supplied for domestic use.

The mixing valve **MUST** be set to prevent a scald injury from occurring, see the caution against scalding.

Storage of water for domestic use above **140°F, 60°C** will provide an increased quantity of tempered water and help prevent the growth of water born bacteria.

Table 9A - Spectrum Heat Exchanger Selection Graph

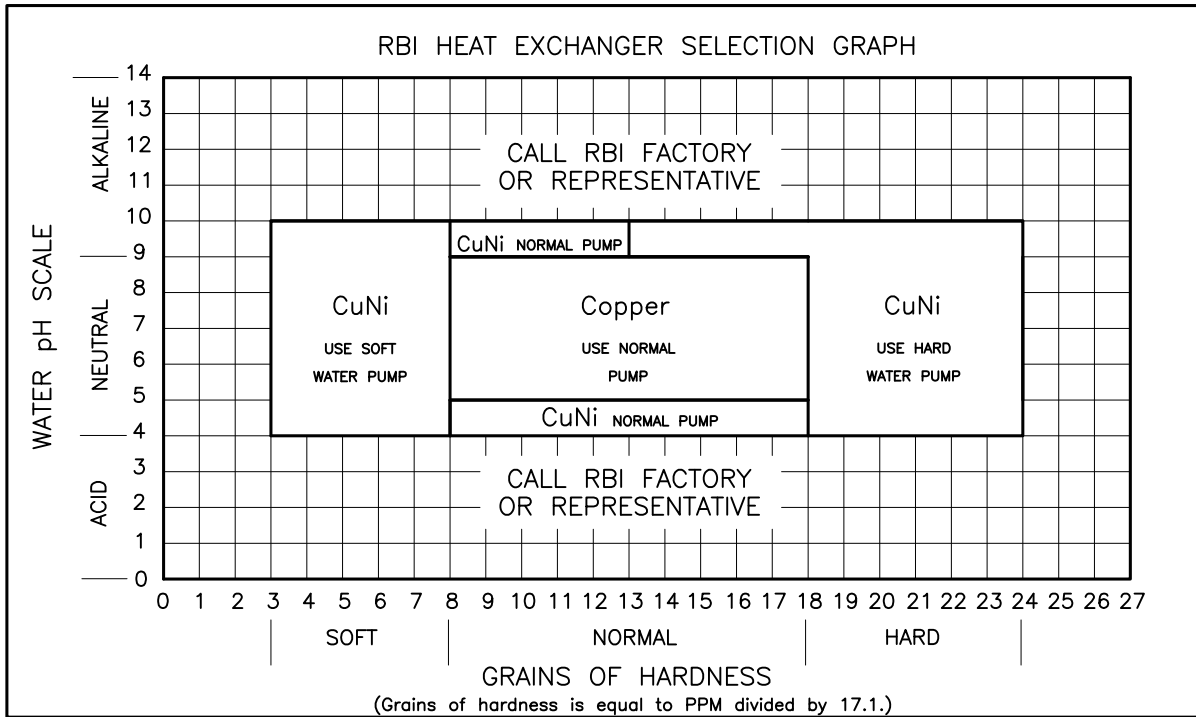

Copyright Pending, MESTEK 12/03

Table 9B - Spectrum Pumping Performance Requirement Table

SPECTRUM PUMPING PERFORMANCE REQUIREMENTS

WATER HARDNESS	SOFT			NORMAL			HARD		
HEAT EXCH. TYPE	CuNi			Copper			CuNi		
MODEL	GPM	ΔP	ΔT	GPM	ΔP	ΔT	GPM	ΔP	ΔT
SW-0100 2-PASS	30	0.14	6.0	60	0.52	3.0	90	1.09	2.0
SW-0150 2-PASS	30	0.19	8.0	60	0.68	4.0	90	1.43	3.0
SW-0200 2-PASS	30	0.23	11.0	60	0.83	6.0	90	1.77	4.0
SW-0250 2-PASS	30	0.27	14.0	60	0.99	7.0	90	2.10	5.0
SW-0300 2-PASS	30	0.32	17.0	60	1.15	8.0	90	2.44	6.0
SW-0350 2-PASS	30	0.36	19.0	60	1.31	10.0	90	2.77	6.0
SW-0400 2-PASS	30	0.41	22.0	60	1.47	11.0	90	3.11	7.0
SW-0100 4-PASS	15	0.29	11.0	30	1.03	6.0	45	2.19	4.0
SW-0150 4-PASS	15	0.37	17.0	30	1.35	8.0	45	2.86	6.0
SW-0200 4-PASS	15	0.46	22.0	30	1.67	11.0	45	3.53	7.0
SW-0250 4-PASS	15	0.55	28.0	30	1.98	14.0	45	4.20	9.0
SW-0300 4-PASS	15	0.64	33.0	30	2.30	17.0	45	4.88	11.0
SW-0350 4-PASS	15	0.73	39.0	30	2.62	19.0	45	5.55	13.0
SW-0400 4-PASS	15	0.81	44.0	30	2.94	22.0	45	6.22	15.0

ΔT=Temperature Change=(Outlet Temp.-Inlet Temp.) in F.
 ΔP=Head Loss=(Inlet Pres.-Outlet Pres.) in feet of Water Column.
 To achieve the proper flow rate adjust outlet valve on heater piping to obtain the correct ΔT.
 Call factory if grains of hardness is less than 3 or greater than 24.

SPECIAL REQUIREMENTS
 (CALL FACTORY OR REPRESENTATIVE)

Copyright Pending, MESTEK 12/03

Figure 8 - Typical Water Heating Piping (MW Models Only)
(See Notes)

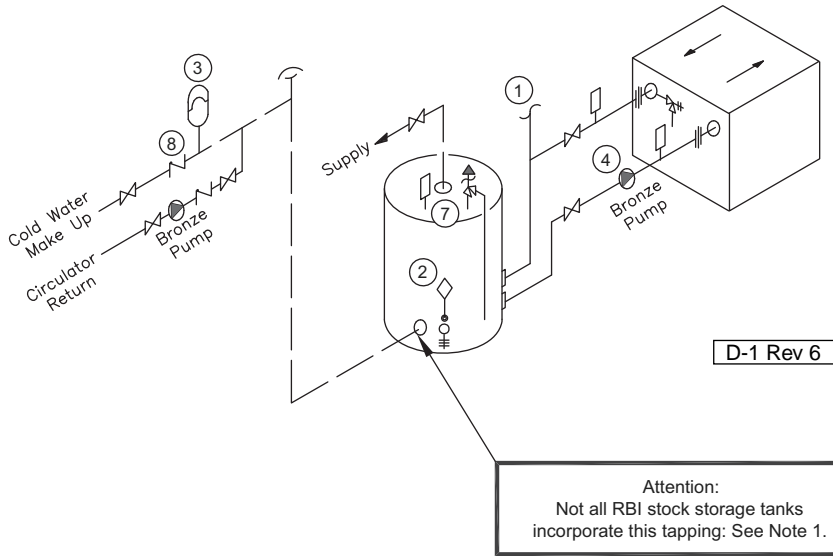

LEGEND:

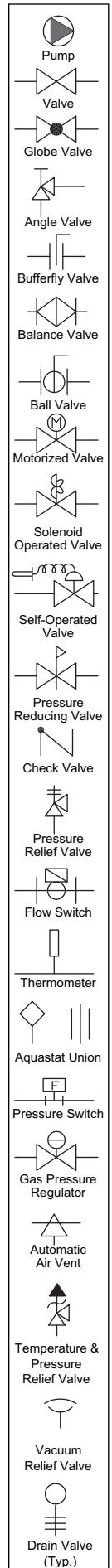
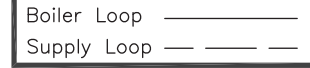
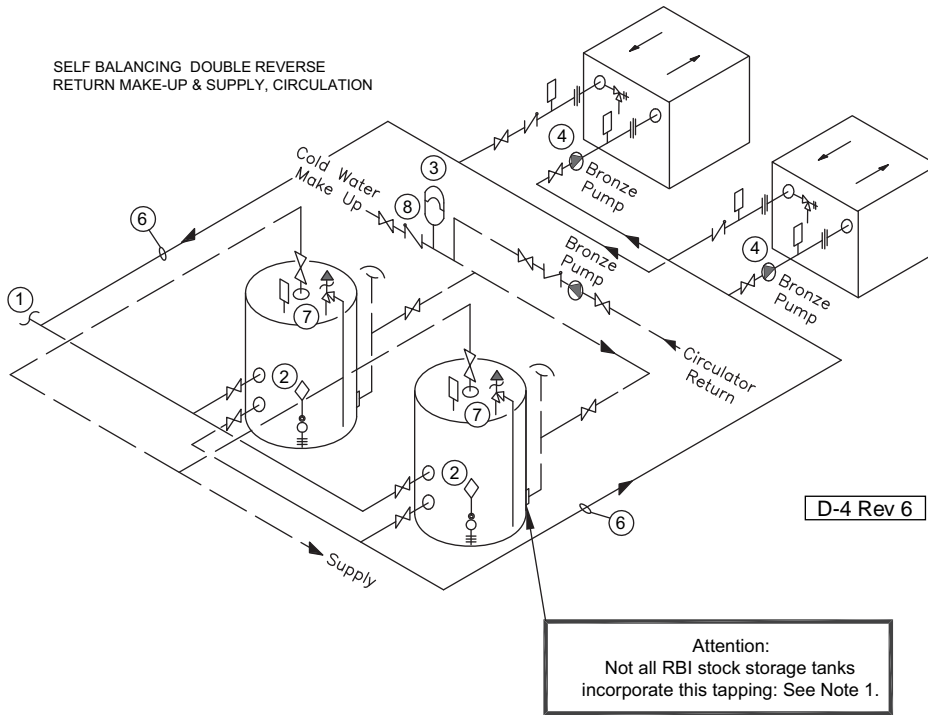

Figure 9 - Multiple Water Heating Piping (MW Models Only)
(See Notes)



NOTES:

1. Optional cold water make up and recirculation line location.
2. When using intermittent pump and pump delay, locate remote aquastat well in lower 1/3 of tank. Install aquastat with heat sensing compound.
3. Thermal expansion tank may be required, check local codes.
4. When using optional factory mounted pump, max pipe length 30' total, 6-90° elbows, full pipe size.
5. CAUTION: MEASURE WATER HARDNESS AND pH AT JOB SITE.
The pH and water hardness must be measured before selecting heat exchanger and pump. Consult the Heat Exchanger Graph and Pumping Performance Table before making selection.
6. Common piping must be sized for maximum combined heater flow.
7. Hot water tanks should be equipped with a combination temperature & pressure relief valve.
8. MA Code requires an 1/8" hole in check valve to compensate for thermal expansion.

Notice: These drawings show suggested piping configuration and valving. Check with local codes and ordinances for specific requirements.

GAS SUPPLY PIPING

WARNING: Check the boiler/water heater rating plate to make sure that the boiler/water heater is for the type of gas that will be used. If it isn't, do not connect the boiler/water heater to the gas supply. Gas supply piping must be in accordance with the National Fuel Code, ANSI Z223.1-latest revision or applicable provisions of the local building codes. Canadian Installations must comply with CAN/CGA B149.1 or .2 Installation Code. Failure to comply with this warning can result in extensive property damage, severe personal injury or death!

The Spectrum boiler/water heaters come from the factory ready to be piped to the gas supply. If for any reason the boiler/water heater is not for the type of gas available at the installation site, call the nearest RBI representative to resolve the problem.

NOTE: A minimum gas supply pressure of 5 in, 127 mm W.C. natural or 12 in, 305 mm W.C. propane and maximum gas supply pressure of 14 in, 356 mm W.C. natural or propane, must be available at the safety shutoff valve inlet with the unit(s) operating.

Table 10 should be used to ensure that the gas supply piping is sized properly. If more than one appliance is supplied by the same supply pipe, the piping must be sized based on the maximum possible demand. Do not neglect the pressure drop due to pipe fittings. Table 10 should be used in conjunction with Table 11 to ensure that the gas supply piping has the capacity to meet the demand.

Table 10 - Gas Pipe Capacity

Maximum pipe capacity in ft ³ /hr based on 0.60 specific gravity gas at a pressure of 0.5 psig or less and a 0.3" W.C. pressure drop.									
Nominal Iron Pipe Size, (in)	Pipe length in feet								
	10	20	30	40	50	60	80	100	150
Maximum gas volume of pipe, (ft ³ /hr)									
3/4"	278	190	152	130	115	105	90	79	64
1"	520	350	285	245	215	195	170	150	120
1 1/4"	1050	730	590	500	440	400	350	305	250
1 1/2"	1600	1100	890	760	670	610	530	460	380
2"	3050	2100	1650	1450	1270	1150	990	870	710
2 1/2"	4800	3300	2700	2300	2000	1850	1600	1400	1130
3"	8500	5900	4700	4100	3600	3250	2800	2500	2000
4"	17,500	12,000	9700	8300	7400	6800	5800	5100	4100

Note: Multiply the gas volume by 0.62 for propane flow capacity in ft³/hr. Multiply the propane flow capacity by 2500 Btu/ft³ to determine the propane Btu/hr capacity for a given pipe size and length.

Table 11 - Equivalent Pipe Length

Nominal Iron Pipe Size, (in)	Type of pipe fitting			
	90° Elbow	Tee ¹	Gate Valve ²	Gas Cock ²
	Equivalent of pipe length (ft)			
1"	2.6	5.2	0.6	1.5
1 1/4"	3.5	6.9	0.8	1.9
1 1/2"	4.0	8.0	0.9	2.3
2"	5.2	10.3	1.2	3.0
2 1/2"	6.2	12.3	1.4	3.7
3"	7.7	15.3	1.8	4.5
4"	7.7	15.3	1.8	4.5

Notes: 1. For flow through branch.
2. For flow at full open.

Figure 10 depicts the proper way to connect the boiler/water heater to the gas supply piping. The manual shut-off valve **MUST** be installed in the supply piping. It should be installed **5 ft, 1.5 m** above the floor where required by local codes. Provide a sediment trap at the bottom of the vertical section of the gas supply pipe upstream of the gas controls.

A ground joint union should be installed between the boiler gas controls and the supply piping. Each of these items are needed to ensure long life and ease of servicing. Always use a pipe sealant that is suitable for use with LP gas.

Figure 10 - Gas Supply Piping

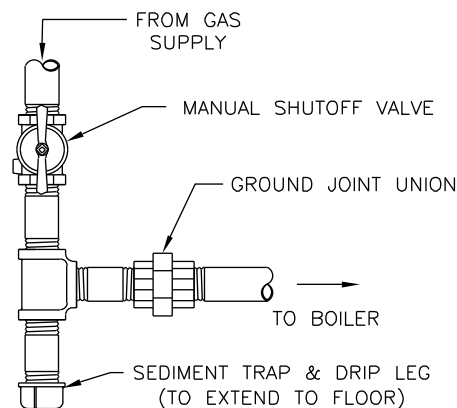

RIOM-47

CAUTION: Always use a wrench on the gas valve body when making gas connections to it. Never over-tighten the piping entering the gas valve body or gas valve failure may result!

When applicable, provisions for vent, bleed and gas relief lines must be made in accordance with the latest revision of ANSI Z223.1/NFPA 54.

Safe lighting and other performance criteria were met with the gas manifold and control assembly provided on the boiler. All gas connections MUST be leak tested before putting the boiler into operation.

WARNING: Never use an open flame to test for gas leaks. Always use an approved leak detection method. Failure to comply with this warning can cause extensive property damage, severe personal injury or death!

Whenever the gas supply piping is pressure tested the boiler/water heater gas controls must be protected. If the test pressure is equal to, or less than **1/2 psig, 3.5 kPa** isolate the boiler/water heater by closing it's manual shut off valve, see Figure 10. If the test pressure is greater than, or equal to **1/2 psig, 3.5 kPa**, disconnect the boiler/water heater and its individual shut-off valve.

Required Gas Pressure

Provide gas supply pressure at inlet to boiler gas train as follows:

	LP	Nat
Minimum (in W.C.)	12	5
Maximum (in W.C.)	14	14

Measure pressure when boiler is firing at full rate. Low gas pressure could indicate undersized gas line or insufficient gas supply.

"Static and operating gas pressure required at the gas valve inlet is between 5" W.C. and 14" W.C. for natural gas and 12" W.C. and 14" W.C. for propane. If the gas pressure is above this limit, a lock-up style regulator suitable for dead end service such as an Equimeter or Fisher must be installed to prevent increase (creep) of gas pressure when the units are not operating. This pressure regulator (supplied by others) may be installed at the service entrance to each unit or a "master" regulator sized to handle multiple units may be utilized. Consult local gas utility or regulator manufacturer for recommendations to meet specific job site requirements."

ELECTRICAL WIRING

Electrical Power Connections

CAUTION: Label all wires prior to disconnection when servicing controls. Wiring errors can cause improper and dangerous operation! Verify proper operation after servicing!

ATTENTION. Au moment de l'entretien des commandes, étiquetez tous les fils avant de les débrancher. Des erreurs de câblage peuvent entraîner un fonctionnement inadéquat et dangereux. S'assurer que l'appareil fonctionne adéquatement une fois l'entretien terminé.

The electrical connections to this boiler/water heater must be made in accordance with all applicable local codes and the latest revision of the National Electrical Code, ANSI/NFPA-70. Installation should also conform with CSA C22.1 Canadian Electrical Code Part I if installed in Canada.

Install a separate 120 volt 15 amp circuit for the boiler/water heater and circulator pump. A shut-off switch should be located at the boiler/water heater. The boiler/water heater must be grounded in accordance with the authority having jurisdiction, or if none, the latest revision of the National Electrical Code, ANSI/NFPA-70.

Line voltage field wiring of any controls or other devices must conform to the temperature limitation of type T wire at **95°F, 35°C** above room temperature. Use copper conductors with a minimum size of #14 awg.

Refer to the wiring diagram supplied with the boiler/water heater for proper wiring connections.

GENERAL OPERATION

WARNING: Before proceeding read and fully understand the instructions contained in this manual. Do not attempt to operate this boiler/ water heater if it has not been installed in accordance with the guidelines set forth in this manual. Failure to comply with this warning can result in extensive property damage, severe personal injury or death!

Should overheating occur or the gas supply fail to shut off, turn off the manual gas control valve to the appliance. Do not interrupt water flow through the boiler/ water heater.

En cas de surchauffe ou si l'alimentation en gaz ne s'arrête pas, fermez manuellement le robinet d'arrêt de l'admission de gaz.

Hydronic Heating Boilers

Open the make-up water valve and slowly fill the boiler and all of the radiation with water. Ensure that all bleed and drain valves are closed.

Adjust the make-up water pressure regulator so a minimum **12 psig**, *82.7 kPa* system pressure is maintained at the highest point in the system piping. If a make-up water pump is used adjust to maintain a minimum **12 psig**, *82.7 kPa* system pressure.

Open the system bleed and drain valves, one at a time, to purge the air trapped in the heating system piping.

With the boiler off, run the system pump for at least 30 minutes and bleed the system piping using the bleed valves. If strainers are used in the system piping, the make-up water valve should be closed and the strainers checked and cleaned.

The system expansion tank should be checked to ensure that the correct water level in the tank is maintained. The tank should be less than half full of water with the system full and adjusted to the correct operating pressure.

Start the boiler as described in the "LIGHTING AND OPERATING INSTRUCTIONS" on the next page. Run the boiler for at least an hour. The system pump(s) and all radiation units must be operated during this time. Ensure that the make-up water valve is open.

Shut the boiler off and open the bleed valves to purge the air trapped in the heating system piping. Close the make-up water valve and check and clean the strainers and make-up water pressure reducing valve.

Open the make-up water valve and adjust the system pressure if necessary. The system should be checked and bled after three days of operation.

FOR YOUR SAFETY READ BEFORE LIGHTING

WARNING: If you do not follow these instructions exactly, a fire or explosion may result causing property damage, personal injury or loss of life.

- A. If this appliance is equipped with a **continuous pilot**, it must be lit by hand. Follow the lighting instructions exactly.
- B. BEFORE LIGHTING smell all around the appliance area for gas. Be sure to smell next to the floor because some gas is heavier than air and will settle on the floor.
- C. Use only your hand to push in or turn the gas control knob. Never use tools. If the knob will not push in or turn by hand, don't try to repair it, call a qualified service technician. Force or attempted repair may result in a fire or explosion.
- D. Do not use this appliance if any part has been under water. Immediately call a qualified service technician to inspect the appliance and to replace any part of the control system and any gas control that has been under water.

DANGER: Propane gas may not always be detected by smell. Propane gas is heavier than air and can collect in low areas.

Propane gas can ignite or explode if an ignition source is present and result in death, serious injury and property damage!

FOR YOUR SAFETY:

- Have only qualified licensed professionals install, service and maintain this appliance and your gas system in accordance with all applicable codes.
- Install a nationally listed combustible gas detector(s) in your home.
- If you suspect a leak:
 1. Have everyone leave the building immediately.
 2. Do not attempt to light any appliance.
 3. Do not touch any electrical or electronic switches in the building.
 4. Do not use any phone in the building.
 5. Call your gas supplier from a phone outside of the building.
 6. If you cannot reach your gas supplier call the fire department.

LIGHTING INSTRUCTIONS

1. STOP! Read the safety information above.
2. Set the thermostat to lowest setting.
3. Remove control access panel.
4. Push in gas control knob slightly and turn clockwise

to "OFF",

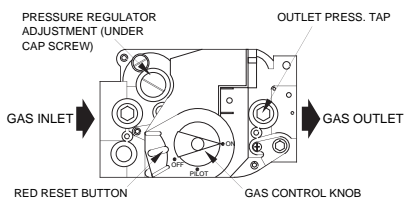

5. Wait five (5) minutes to clear out any gas. Then smell for gas, including near the floor. If you smell gas, STOP! Follow "B" in the safety information above (to the left) on this label. If you do not smell gas, go to the next step.
6. Open the pilot sight door above the main burners.
7. Find pilot – follow metal tube from the gas control. The pilot is between the two burner tubes behind the pilot sight door.

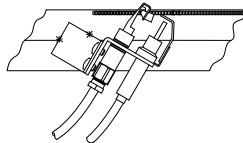

8. Turn knob on gas control counterclockwise to "PILOT".
9. Push in control knob all the way and hold in. Immediately light the pilot with a match. Continue to hold the control knob in for about one (1) minute after the pilot is lit. Release knob and it will pop back up. Pilot should remain lit. If it goes out, repeat step 4 through 9.
 - If knob does not pop up when released, STOP and immediately call your service technician or gas supplier.
 - If the pilot will not stay lit after several tries, turn the gas control knob to "OFF" and call your service technician or gas supplier.
10. Close pilot sight door.
11. Turn gas control knob counterclockwise to "ON".
12. Replace control access panel.
13. Set thermostat to desired setting.

TO TURN OFF GAS TO APPLIANCE

1. Set the thermostat to lowest setting.
2. Remove control access panel.
3. Push in gas control knob slightly and turn clockwise to "OFF". Do not force.
4. Replace control access panel.

FOR YOUR SAFETY READ BEFORE OPERATING

WARNING: If you do not follow these instructions exactly, a fire or explosion may result causing property damage, personal injury or loss of life.

- A. If this appliance is equipped with an **electronic ignition device**, this automatically lights the burner. Do not try to light the burner by hand.
- B. BEFORE OPERATING smell all around the appliance area for gas. Be sure to smell next to the floor because some gas is heavier than air and will settle on the floor.
- C. Use only your hand to push in or turn the gas control knob. Never use tools. If the knob will not push in or turn by hand, don't try to repair it, call a qualified service technician. Force or attempted repair may result in a fire or explosion.
- D. Do not use this appliance if any part has been under water. Immediately call a qualified service technician to inspect the appliance and to replace any part of the control system and any gas control that has been under water.

DANGER: Propane gas may not always be detected by smell. Propane gas is heavier than air and can collect in low areas.

Propane gas can ignite or explode if an ignition source is present and result in death, serious injury and property damage!

FOR YOUR SAFETY:

- Have only qualified licensed professionals install, service and maintain this appliance and your gas system in accordance with all applicable codes.
- Install a nationally listed combustible gas detector(s) in your home.
- If you suspect a leak:
 1. Have everyone leave the building immediately.
 2. Do not attempt to light any appliance.
 3. Do not touch any electrical or electronic switches in the building.
 4. Do not use any phone in the building.
 5. Call your gas supplier from a phone outside of the building.
 6. If you cannot reach your gas supplier call the fire department.

OPERATING INSTRUCTIONS

1. STOP! Read the safety information above.
2. Set the thermostat to lowest setting.
3. Turn off all electric power to the appliance.
4. This appliance is equipped with an ignition device, which automatically lights the pilot. Do not try to light the pilot by hand!

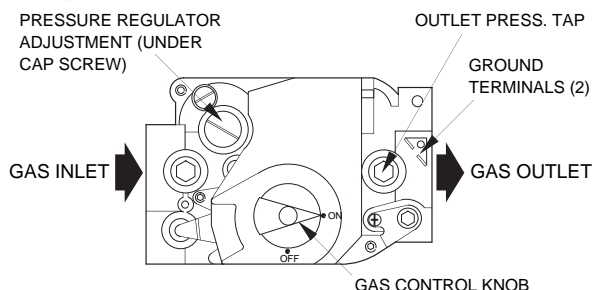

5. Remove control access panel.
6. Push in gas control knob slightly and turn clockwise to "OFF".
7. Wait five (5) minutes to clear out any gas. Then smell for gas, including near the floor. If you smell gas, STOP! Follow "B" in the safety information above (to the left) on this label. If you do not smell gas, go to the next step.
8. Turn the gas control knob counterclockwise to "ON".
9. Replace control access panel.
10. Turn on all electric power to the appliance.
11. Set thermostat to desired setting.
12. If the appliance will not operate, follow the instructions "TO TURN OFF GAS TO APPLIANCE" and call your service technician or gas supplier.

TO TURN OFF GAS TO APPLIANCE

1. Set the thermostat to lowest setting.
2. Turn off all electric power to the appliance if service is to be performed.
3. Remove control access panel.
4. Push in gas control knob slightly and turn clockwise to "OFF". Do not force.
5. Replace control access panel.

CHECKING & ADJUSTMENTS

Pilot Adjustment

The pilot burner flame should envelope **3/8 in to 1/2 in, 9.5 mm to 12.7 mm** of the flame sensing probe, Figure 11. To adjust the pilot the following steps must be taken:

1. Remove the pilot gas pressure regulator cap.
2. Turn the pressure regulator adjustment screw clockwise to decrease the flame and counterclockwise to increase it.
3. Replace the pressure regulator adjustment screw cap.

Figure 11 - Pilot Flame Adjustment

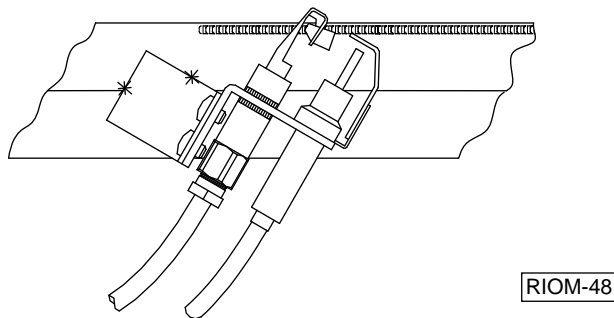

Gas Pressure Adjustment

CAUTION: The maximum inlet gas pressure listed on the rating plate must not be exceeded or damage to the boiler/water heater may occur!

The minimum supply pressure listed on the rating plate is for input adjustment.

NATURAL GAS: Optimum results are obtained when the boiler/water heater is operated at its full input rating, with **3.8 in to 4.2 in, 96.5 mm to 106.7 mm** W.C. of manifold pressure. The manifold pressure should not vary outside this range. The gas valve pressure regulator has been preset at the factory. If adjustment is necessary the following steps must be followed:

1. Attach a **20 in, 508 mm** W.C. manometer to the tap on the manifold.
2. Remove the regulator adjustment screw cap from the gas regulator. On systems that do not use a separate gas regulator, remove the adjustment screw cap from the gas valve body on the valve closest to the gas supply piping.
3. Rotate the regulator adjustment screw clockwise to increase the manifold pressure, counterclockwise to decrease it.
4. Replace the regulator adjustment screw cap and manifold pressure tap plug.

CAUTION: Never force the regulator adjustment screw beyond the stop limits or damage to the regulator will occur!

PROPANE GAS: A manifold pressure of **11 in, 279 mm** W.C. must be maintained for proper operation of the boiler. If the manifold pressure is off by more than 5% adjust it according to steps 1 through 4.

Input Rate, Natural Gas

Gas appliances are rated based on sea level operation with no adjustment required at elevations up to **2000 ft, 610 m**. At elevations above **2000 ft, 610 m**, input ratings should be reduced by 4% for each additional **1000 ft, 305 m**.

Check the input rate as follows:

1. Turn off all other gas appliances that use the same gas meter as the boiler/water heater.
2. Call your gas supplier and ask for the heating value of the gas.
3. Start the boiler/water heater and let it run for 15 minutes.
4. Using the gas meter and a stopwatch, clock the time that it takes to burn **10 ft³, 0.28m³** of gas and divide this time by 10.
5. Insert the heating value and the time, in seconds, into the formula below.
6.
$$\text{Input} = (\text{heating value, Btu/hr})(3600)/(\text{time, seconds})$$
7. If the computed rate deviates by more than 5% from the rated input value of the unit adjust the manifold pressure accordingly. **DO NOT** adjust the manifold pressure by more than 5%. If a proper rate cannot be maintained without adjusting the manifold pressure beyond the 5% limit, the main burner orifices must be replaced. If the input rate is too low, go to the next larger size of main burner orifices. If the input rate is too high, go to the next smaller size.

CAUTION: Never increase the input to the boiler/water heater above that for which it is rated. Doing so can cause premature failure of the unit!

CONTROL DESCRIPTION

Low Water Cutoff

If the boiler is to be installed above radiation or if required by other codes or regulations, install a low water cutoff in appropriate piping.

If installed, ensure that the low water cutoff device(s) function properly. Test in accordance with the manufacturer's instructions included with the device(s).

Boiler Thermostat

If a thermostat is to be used to control the boiler always follow the instructions included with the thermostat. Proper location of the thermostat will ensure efficient trouble-free operation of the boiler. Mount the thermostat to an inside wall at a height approximately five feet above the floor.

Avoid placing the thermostat in areas that will not provide an accurate measurement of the room temperature. Locating the thermostat behind a door, in an alcove, close to a source of thermal radiation or in a drafty area will cause poor or sporadic heating.

For a thermostat that employs an adjustable heat anticipator, adjust the anticipator to match the current measured in the thermostat circuit. An increased anticipator setting may be necessary if the unit cycles frequently. If the room temperature over-shoots the thermostat setting, reduce the anticipator setting.

Operating Control

The preferred control setting for potable hot water is **130°F, 54°C**. The operating control should be set to the lowest setting that will satisfy the consumer's needs.

WARNING: Setting the thermostat or operating control too high can result in scalding resulting in severe personal injury!

High Limit (Aquistat)

The high limit is located in the top control area of the boiler/water heater. A remote capillary bulb is run to a well on the outlet side of the supply header.

The water heater high limit should be set a minimum of **20°F, 11°C** higher than the operating control. Refer to the HOT WATER SUPPLY section for the proper supply water temperature.

Flow Switch

A flow switch is provided in the water outlet piping to prevent the boiler/water heater from firing without adequate water flow through the heat exchanger.

MAINTENANCE

WARNING: Disconnect electrical power and close the manual gas shut off valve before performing maintenance or severe personal injury may result!

WARNING: Improper installation, adjustment, alteration, service or maintenance can cause property damage, personal injury, exposure to hazardous materials or loss of life. Installation and service must be performed by a qualified installer, service agency or the gas supplier who must read and follow the supplied instructions before installing, servicing or removing this boiler. This boiler contains crystalline silica materials that have been identified as carcinogenic or possibly carcinogenic to humans when inhaled.

AVERTISSEMENT: Une installation, un réglage, une réparation ou un entretien non conforme aux normes peut entraîner des dommages matériels, des blessures, exposition à des matières dangereuses ou la mort. L'installation et l'entretien doivent être effectués par un installateur ou un service d'entretien qualifié ou le fournisseur de gaz qui doivent avoir lu les instructions fournies avant de faire l'installation, l'entretien ou l'enlèvement de la chaudière et les respecter. Cette chaudière contient des matériaux qui ont été identifiés comme étant cancérigènes ou pouvant l'être.

CAUTION: Servicing, inspection and adjustment must be done by a trained technician in accordance with all applicable local and national codes. Improper servicing or adjustment can damage the boiler/water heater!

WARNING: The ceramic combustion chamber contains crystalline silica. Wear a tightly fitted dust mask when removing the burners or heat exchanger to prevent inhalation of airborne fibers. Crystalline silica fibers have been identified as carcinogenic, or possibly carcinogenic when inhaled.

The boiler/water heater should be cleaned and inspected once a year and before each heating season. Make sure that the burners and ignition components are free from dust, soot, dirt, corrosion or other deposits that would impair the boiler's performance. Refer to page 24 for component identification.

CAUTION: Improper burner servicing can result in premature burner failure voiding the warranty!

Burner Drawer & Burner Removal

1. Close the manual shutoff valves in the gas supply lines and turn off electrical power to the boiler/water heater.
2. Disconnect the gas train from the gas supply piping at the ground joint union.
3. Remove the flame roll-out shield.
4. Remove the two screws that attach the burner drawer to the base panel, Figure 12.
5. Disconnect the electrical wires going to the gas valve and burner drawer.
6. On intermittent pilot models disconnect the ignition cable from the ignition module.
7. Pull the burner drawer out until the burners are fully exposed.
8. Inspect each burner for damage or signs of deterioration. Use a brush or compressed air to remove any debris from the burner ports.
9. DO NOT install damaged or badly corroded burners, replace them.
10. Reinstall the burner drawer and flame roll-out shield following the removal steps in reverse order.
11. Reconnect all electrical wires.
12. Reconnect the gas piping.

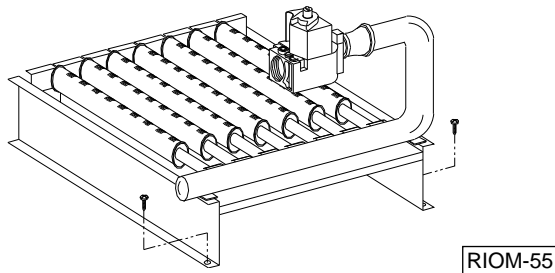
Figure 12 - Burner Drawer Assembly**Combustion Chamber Inspection**

1. Remove the burner drawer following the instructions above.
2. Inspect the combustion chamber panels using a mirror and light. If any of the combustion chamber panels are damaged or show signs of deterioration replace them.
3. Replacement of the combustion chamber panels requires that the heat exchanger be removed as outlined below.
4. Reinstall the burner drawer as outlined above.

Heat Exchanger Inspection & Cleaning

1. Close the manual shutoff valve in the gas supply line and turn off electrical power to the boiler/water heater.
2. Close the shut off valves in the inlet and outlet piping. Relieve the system pressure from the boiler/water heater by carefully opening the drain valve.
3. Disconnect the boiler/water heater from the system piping.
4. Remove the left and right headers and mounting studs.
5. Disconnect the flue pipe at the boiler/water heater.
6. Remove the top jacket panel.
7. On indoor units remove the draft hood from the back of the unit. On outdoor units remove the rear jacket panel.
8. Remove the flue collector.
9. Carefully lift the heat exchanger out of the unit and thoroughly inspect it.
10. The outside surfaces of the copper tubes should be free of any soot deposits. A slight black smudge is normal with some types of gases. Black soot indicates poor combustion. Green deposits indicate condensation due to low return water temperatures. In either case the heat exchanger must be cleaned thoroughly with water and the problem resolved before the boiler/water heater is returned to service.
11. Replace the cleaned heat exchanger and other components in the reverse order of their removal.

12. The torque values for the Spectrum header bolts are all the same: 17-20 ft. lbs. the bolts should be fastened then tightened in the following sequence:
 - 1) Middle Top
 - 2) Middle Bottom
 - 3) Right Top
 - 4) Left Bottom
 - 5) Left Top
 - 6) Right Bottom

Heat Exchanger Replacement

1. Sagging or distorted heat exchanger tubes are an indication of low water flow through the system.
2. A damaged heat exchanger must be replaced and the condition that caused the damage resolved before the boiler/water heater is returned to service.

Vent System

Thoroughly inspect the vent system for any signs of blockage, corrosion or leakage. Immediately replace any unsound vent system piping.

Controls

Use the "GENERAL OPERATION" and "CHECKING AND ADJUSTMENTS" sections of this manual for reference.

1. Check the thermostat or operating controls for proper operation.
2. A float type low water cutoff device must be flushed out per the manufacturers' instructions. The probe on a probe low water cut off must be removed, cleaned and inspected at least once a year. Ensure that the low water cutoffs operate properly. If not, replace them.
3. The flow switch contacts must be open when water flow is not present.
4. The relief valve should not weep or discharge water at normal system pressure. If it does contact a qualified service technician to have it inspected. NEVER try to clean or repair the relief valve! If the valve fails to operate properly, have it replaced!
5. The aquastat high limit controls the maximum water temperature in the boiler. It should be set at least **20°F, 11°C** above the operator set point. If the water temperature reaches the set temperature before the demand for heat has been met, the aquastat high limit should shut the boiler off. The water temperature should never exceed the maximum set point of **240°F, 116°C**. The aquastat high limit cannot be repaired. If it fails to function properly, replace it.
6. Visually check the pilot and main burner flames to ensure proper operation, see Figures 11 & 13.

WARNING: Yellow, floating flames indicate a lack of combustion air. A lifting flame indicates too much combustion air. Do not operate the boiler until the problem is solved or severe personal injury or death may occur!

Figure 13 - Main Burner Flames

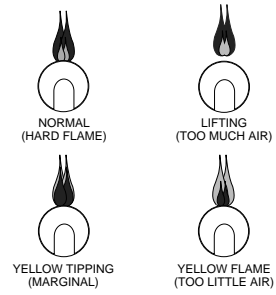

RIOM-49

Figure 14 - Replacement Parts

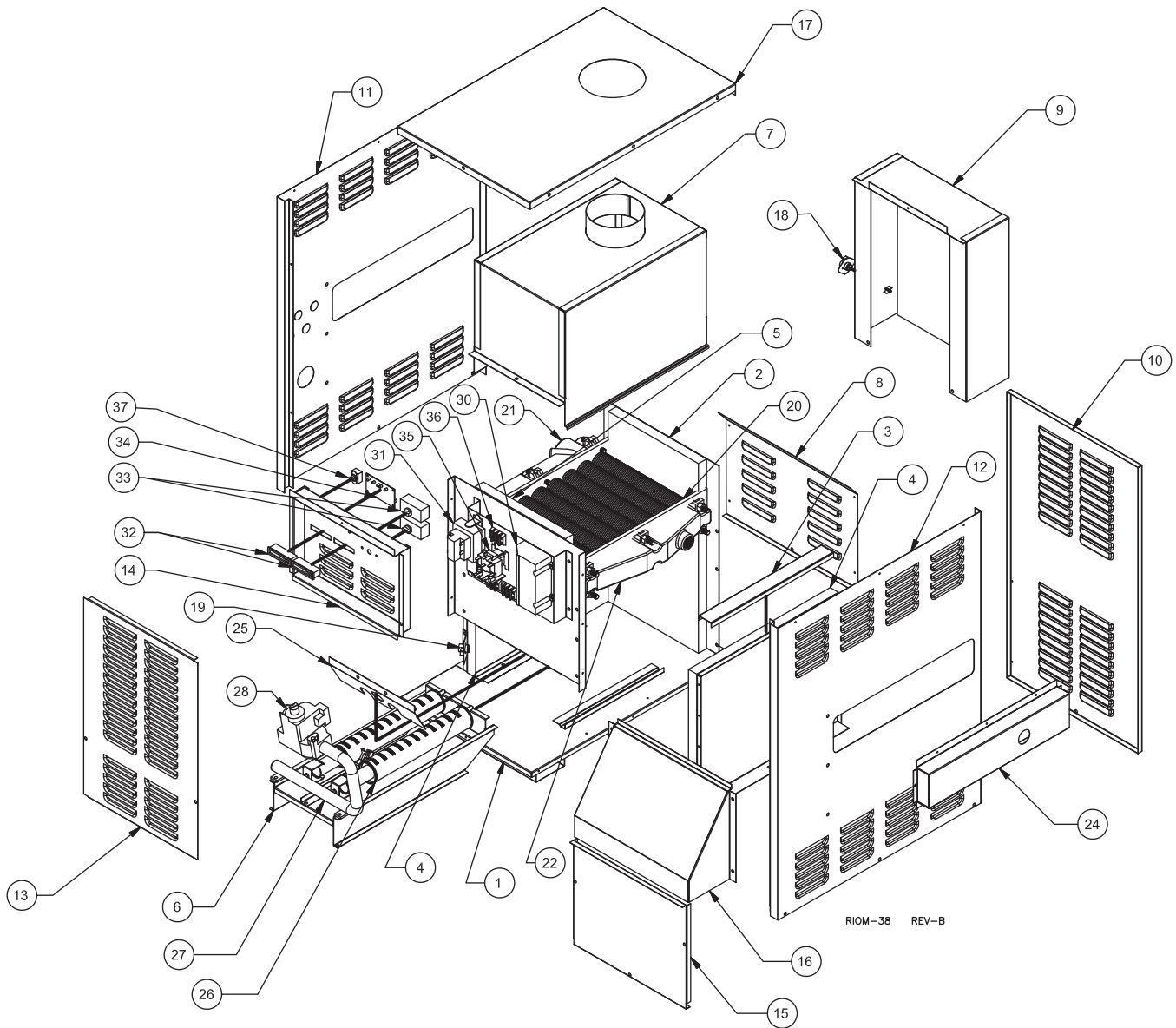

RIOM-38 REV-B

SERVICE AND REPLACEMENT PARTS LIST (MODELS 100-400)

Ref #	Name of Part	Part No.	Model Size With Item Quantities Below						
			100	150	200	250	300	350	400
1	Combustion Chamber Base Assembly (Outdoor)	70-1221	1						
		70-1222		1					
		70-1223			1				
		70-1224				1			
		70-1225					1		
		70-1226						1	
		70-1227							1
	Combustion Chamber Base Assembly	70-1240	1						
		70-1241		1					
		70-1242			1				
		70-1243				1			
		70-1244					1		
		70-1245						1	
	Combustion Chamber Rear Panel	70-1246							1
		03-0886	1						
		03-0887		1					
		03-0888			1				
		03-0889				1			
		03-0890					1		
		03-0891						1	
	Combustion Chamber Front Panel	03-0892							1
03-0894		1							
03-0895			1						
03-0896				1					
03-0897					1				
03-0898						1			
03-0899							1		
Combustion Chamber Side Panel, Left & Right	03-0900							1	
	03-0901	2	2	2	2	2	2	2	
	2	Rear Refractory Panel	05-0035	1					
			05-0036		1				
			05-0037			1			
			05-0038				1		
05-0039							1		
05-0040								1	
05-0041							1		
3	Upper Refractory Channel	03-0884	2	2	2	2	2	2	
4	Side Refractory Panel, Left & Right	05-0033	2	2	2	2	2	2	
5	Front Refractory Panel	05-0043	1						
		05-0044		1					
		05-0045			1				
		05-0046				1			
		05-0047					1		
		05-0048						1	
05-0049							1		
2, 4, 5	Tile Kit	70-1554K	1						
		70-1555K		1					
		70-1556K			1				
		70-1557K				1			
		70-1558K					1		
		70-1559K						1	
70-1560K							1		

Ref #	Name of Part	Part No.	Model Size With Item Quantities Below						
			100	150	200	250	300	350	400
9	Draft Hood Assembly	70-1272	1						
		70-1273		1					
		70-1274			1				
		70-1275				1			
		70-1276					1		
		70-1277						1	
		70-1278							1
10	Jacket Rear Panel (Outdoor)	03-0719	1						
		03-0720		1					
		03-0721			1				
		03-0722				1			
		03-0723					1		
		03-0724						1	
		03-0725							1
11	Jacket Left Side Panel	03-0774	1	1	1	1	1	1	1
12	Jacket Right Side Panel	03-0775	1	1	1	1	1	1	1
13	Jacket Front Panel	03-0767	1						
		03-0768		1					
		03-0769			1				
		03-0770				1			
		03-0771					1		
		03-0772						1	
		03-0773							1
14	Jacket Upper Front Panel	03-0757	1						
		03-0758		1					
		03-0759			1				
		03-0760				1			
		03-0761					1		
		03-0762						1	
		03-0763							1
15	Jacket Front Panel (Outdoor)	03-0727	1						
		03-0728		1					
		03-0729			1				
		03-0730				1			
		03-0731					1		
		03-0732						1	
		03-0733							1
16	Outdoor Hood Assembly	70-1213	1						
		70-1214		1					
		70-1215			1				
		70-1216				1			
		70-1217					1		
		70-1218						1	
		70-1219							1
NS	Vent Cap & Collar Kit (Outdoor)	09-0121	1						
		09-0122		1					
		09-0123			1				
		09-0124				1	1		
		09-0125						1	
		09-0126							1

Ref #	Name of Part	Part No.	Model Size With Item Quantities Below							
			100	150	200	250	300	350	400	
17	Jacket Top Panel	03-0741	1							
		03-0742		1						
		03-0743			1					
		03-0744				1				
		03-0745					1			
		03-0746						1		
		03-0747							1	
NS	Jacket Top Panel (Outdoor)	70-1205	1							
		70-1206		1						
		70-1207			1					
		70-1208				1				
		70-1209					1			
		70-1210						1		
		70-1211								1
18	Spill Switch	14-0226	1	1	1	1				
19	Flame Roll-Out Switch	14-0225	1	1	1	1				
20	Tube Bundle (Copper)	70-1312	1							
		70-1313		1						
		70-1314			1					
		70-1315				1				
		70-1316					1			
		70-1317						1		
		70-1318							1	
	Tube Bundle (Cupronickel)	70-1320	1							
		70-1321		1						
		70-1322			1					
		70-1323				1				
		70-1324					1			
		70-1325						1		
		70-1326								1
NS	O Ring, Inlet/Outlet & Return Headers	06-0001	16	16	16	16	16	16	16	
NS	Nut, Inlet/Outlet & Return Headers	57-0492	12	12	12	12	12	12	12	
NS	Stud, Inlet/Outlet & Return Headers	57-0220	12	12	12	12	12	12	12	
21	Inlet/Outlet Header, Cast Iron	01-0008S	1	1	1	1	1	1	1	
	Inlet/Outlet Header, Bronze	01-0010S	1	1	1	1	1	1	1	
NS	Inlet/Outlet Header, Cast Iron (Mod)	01-0008M	1	1	1	1	1	1	1	
NS	Inlet/Outlet Header, Bronze (Mod)	01-0010M	1	1	1	1	1	1	1	
NS	Inlet/Outlet Header, Bronze (4 Pass)	01-0010-1S	1	1	1	1	1	1	1	
NS	Inlet/Outlet Header Bronze (Pool Heater) (Canada Only)	01-0027S	1	1	1	1	1	1	1	
22	Return Header, Cast Iron	01-0009S	1	1	1	1	1	1	1	
	Return Header, Bronze	01-0011S	1	1	1	1	1	1	1	
NS	Return Header, Bronze (4 Pass)	01-0011-1S	1	1	1	1	1	1	1	
24	Return Cover (Outdoor)	03-0737	1	1	1	1	1	1	1	
NS	Heat Exchanger "V" Baffle	03-0869	7							
		03-0870		7						
		03-0871			7					
		03-0872				7				
		03-0873					7			
		03-0874						7		
		03-0875							7	

Ref #	Name of Part	Part No.	Model Size With Item Quantities Below							
			100	150	200	250	300	350	400	
25	Flame Roll-Out Shield	03-0904	1							
		03-0905		1						
		03-0906			1					
		03-0907				1				
		03-0908					1			
		03-0909						1		
		03-0910								1
26	Burner Tube, Stainless Steel	10-0251	2	3	4	5	6	7	8	
27	Manifold	10-0452	1							
		10-0453		1						
		10-0454			1					
		10-0455				1				
		10-0456					1			
		10-0457						1		
		10-0458								1
28	Gas Valve, VR8300A, Con, NG	11-0065	1	1	1					
	Gas Valve, VR8300A, Con, NG	11-0066				1	1	1	1	
	Gas Valve, VR8300A, Con, LP	70-1551	1	1	1					
	Gas Valve, VR8300A, Con, LP	70-1552				1	1	1	1	
	Gas Valve, VR8304M, Int, NG	11-0056	1	1	1	1	1	1	1	
	Gas Valve, VR8304M, Int, LP	70-1076	1	1	1	1	1	1	1	
	Gas Valve, VR8304Q, NG (2 Stage)	11-0084	1	1	1	1	1	1	1	
	Gas Valve, VR8304Q, LP (2 Stage)	70-1579	1	1	1	1	1	1	1	
Gas Valve, 5D5241, NG (Mod)	11-0353	1	1	1	1	1	1	1		
NS	Ignitor, PSE-NA29, NG	70-9019	1	1	1	1	1	1	1	
	Ignitor, PSE-NA29, LP	70-9020	1	1	1	1	1	1	1	
NS	Thermocouple, Q309A	10-0211	1	1	1	1	1	1	1	
30	Ignition Module, S8610M	16-0054	1	1	1	1	1	1	1	
31	Transformer, 50 VA	15-0007	1	1	1	1	1	1	1	
NS	High Limit, EMf-1, (SB)	14-0118	1	1	1					
	High Limit, EMF-5, (SB)	14-0009				1	1	1	1	
	High Limit, EMf-1, (SW)	14-0116	1	1	1					
	High Limit, EMf-5, (SW)	14-0008				1	1	1	1	
NS	Operator, EMf-1, (SB)	14-0118	1	1	1	1	1	1	1	
	Operator, EMf-23, (SB) 2 Stage	14-0007	1	1	1	1	1	1	1	
	Operator, EMf-1, (SW)	14-0116	1	1	1	1	1	1	1	
	Operator, EMf-23, (SW) 2 Stage	14-0010	1	1	1	1	1	1	1	
	Operator, T6031A (pool heater) (Canada Only)	14-0003	1	1	1	1	1	1	1	
32	Inlet Thermometer	14-0004	1	1	1	1	1	1	1	
	Outlet Thermometer	14-0004	1	1	1	1	1	1	1	
NS	Thermometer Well, 3/8 x 2	13-0102	2	2	2	2	2	2	2	
NS	High Limit Well, 3/8 x 3	13-0104	2	2	2	2	2	2	2	
33	High Limit/Operator Knob	14-0120	1	1	1	1	1	1	1	
34	Light Package	40-0052	1	1	1	1	1	1	1	
35	Relay, 24V AC	15-0113	1	1	1	1	1	1	1	
36	Terminal Block 2P	48-0151	1	1	1	1	1	1	1	
	Terminal Block 4P	48-0152	1	1	1	1	1	1	1	
	Terminal Block 8P	48-0154	1	1	1	1	1	1	1	
NS	Pressure Relief Valve 30#	13-0004	1	1	1	1	1	1	1	
NS	Pressure Relief Valve 125#	30-0364	1	1	1	1	1	1	1	
NS	Flow Switch	14-0203	1	1	1	1	1	1	1	
NS	Flow Switch (Outdoor)	14-0205			1	1	1	1	1	
NS	Flow Switch (Potter)	14-0201	1	1	1	1	1	1	1	
NS	Flow Switch (Potter Outdoor)	14-0202	1	1	1	1	1	1	1	
NS	Tridicator (SB)	13-0308	1	1	1	1	1	1	1	
NS	Tridicator (SW)	13-0305	1	1	1	1	1	1	1	

OPTIONS

Ref #	Name of Part	Part No.	Model Size With Item Quantities Below						
			100	150	200	250	300	350	400
37	On/Off Switch	48-0010	1	1	1	1	1	1	1
NS	Orifice, #30, NG	10-0035	2	3	4	5	6	7	8
	Orifice, #31 (2,000' - 3,999'), NG	10-0036	2	3	4	5	6	7	8
	Orifice, #32 (4,000' - 5,999'), NG	10-0037	2	3	4	5	6	7	8
	Orifice, #34 (6,000' - 7,999'), NG	10-0043	2	3	4	5	6	7	8
	Orifice, #47, LP	10-0038	2	3	4	5	6	7	8
	Orifice, #49 (2,000' - 3,999'), LP	10-0040	2	3	4	5	6	7	8
	Orifice, #50 (4,000' - 5,999'), LP	10-0041	2	3	4	5	6	7	8
	Orifice, #51 (6,000' - 7,999'), LP	10-0042	2	3	4	5	6	7	8
NS	Rating Plate	82-0054	1	1	1	1	1	1	1
NS	Paint	66-0013	1	1	1	1	1	1	1
NS	Vent Termination Hood 4"	09-0134	1	1	1	1			
	Vent Termination Hood 6"	09-0112					1	1	1
NS	Vent Damper 5"	09-0007	1						
	Vent Damper 6"	09-0008		1					
	Vent Damper 7"	09-0009			1				
	Vent Damper 8"	09-0010				1	1		
	Vent Damper 9"	09-0012						1	
	Vent Damper 10"	09-0011							1
NS	Combustible Floor Pan	70-1248	1						
		70-1249		1					
		70-1250			1				
		70-1251				1			
		70-1252					1		
		70-1253						1	
		70-1254							1

NOTICE!

Commonwealth of Massachusetts Installation Requirements

(a) For all side wall horizontally vented gas fueled equipment installed in every dwelling, building or structure used in whole or in part for residential purposes, including those owned or operated by the commonwealth and where the side wall exhaust vent termination is less than seven (7) feet above finished grade, in the area of the venting, including but not limited to decks and porches, the following requirements shall be satisfied:

1. **INSTALLATION OF CARBON MONOXIDE DETECTORS.** At the time of installation of the side wall horizontal vented gas fueled equipment, the installing plumber or gasfitter shall observe that a hard wired carbon monoxide detector with an alarm and battery back-up is installed on the floor level where the gas equipment is to be installed. In addition, the installing plumber or gasfitter shall observe that a battery operated or hard wired carbon monoxide detector with an alarm is installed on each additional level of the dwelling, building or structure served by the side wall horizontal vented gas fueled equipment. It shall be the responsibility of the property owner to secure the services of qualified licensed professionals for the installation of hard wired carbon monoxide detectors.
 - a. In the event that the side wall horizontally vented gas fueled equipment is installed in a crawl space or an attic, the hard wired carbon monoxide detector with alarm and battery back-up may be installed on the next adjacent floor level.
 - b. In the event that the requirements of this subdivision can not be met at the time of completion of installation, the owner shall have a period of thirty (30) days to comply with the above requirements; provided, however, that during said thirty (30) day period, a battery operated carbon monoxide detector with an alarm shall be installed.
2. **APPROVED CARBON MONOXIDE DETECTORS.** Each carbon monoxide detector as required in accordance with the above provisions shall comply with NFPA 720 and be ANSI/UL 2034 listed and IAS certified.
3. **SIGNAGE.** A metal or plastic identification plate shall be permanently mounted to the exterior of the building at a minimum height of eight (8) feet above grade directly in line with the exhaust vent terminal for the horizontally vented gas fueled heating appliance or equipment. The sign shall read, in print size no less than one-half (1/2) inch in size, "GAS VENT DIRECTLY BELOW. KEEP CLEAR OF ALL OBSTRUCTIONS".
4. **INSPECTION.** The state or local gas inspector of the side wall horizontally vented gas fueled equipment shall not approve the installation unless, upon inspection, the inspector observes carbon monoxide detectors and signage installed in accordance with the provisions of 248 CMR 5.08(2)(a)1 through 4.

WARNING: Improper venting can result in excessive levels of carbon monoxide which can cause severe personal injury or death!

NOTICE!

Commonwealth of Massachusetts Installation Requirements

In the Commonwealth of Massachusetts, the installation must be performed by a licensed plumber or gas fitter.

(b) Exemptions

The following equipment is exempt from 248 CMR 5.08(2)(a) 1 through 4:

1. The equipment listed in Chapter 10 entitled “Equipment Not Required To Be Vented” in the most current edition of NFPA 54 as adopted by the Board; and
2. Product Approved side wall horizontally vented gas fueled equipment installed in a room or structure separate from the dwelling, building or structure used in whole or in part for residential purposes.

(c) MANUFACTURER REQUIREMENTS - GAS EQUIPMENT VENTING SYSTEM PROVIDED.

When the manufacturer of Product Approved side wall horizontally vented gas equipment provides a venting system design or venting system components with the equipment, the instructions provided by the manufacturer for installation of the equipment and the venting system shall include:

1. Detailed instructions for the installation of the venting system design or the venting system components; and
2. A complete parts list for the venting system design or venting system.

(d) MANUFACTURER REQUIREMENTS – GAS EQUIPMENT VENTING SYSTEM NOT PROVIDED.

When the manufacturer of a Product Approved side wall horizontally vented gas fueled equipment does not provide the parts for venting the flue gases, but identifies “special venting systems”, the following requirements shall be satisfied by the manufacturer:

1. The referenced “special venting system” instructions shall be included with the appliance or equipment installation instructions; and
2. The “special venting systems” shall be Product Approved by the Board, and the instructions for that system shall include a parts list and detailed installation instructions.

(e) A copy of all installation instructions for all Product Approved side wall horizontally vented gas fueled equipment, all venting instructions, all parts lists for venting instructions, and/or all venting design instructions shall remain with the appliance or equipment at the completion of the installation.

WARNING: Improper venting can result in excessive levels of carbon monoxide which can cause severe personal injury or death!

LIMITED WARRANTY

Boilers/Water Heaters Industrial, Commercial and Other Non-Residential Use

The "Manufacturer" warrants to the original owner at the original installation site that the heat exchanger of the Industrial, Commercial, and other Non-Residential Use Boiler (the "Product") will be free from defects in material or workmanship for ten (10) years from the date of installation. Additional twenty one (21) year thermal shock warranty on heat exchanger. If upon examination by the Manufacturer the Product is shown to have a defect in material or workmanship during the warranty period, the Manufacturer will repair or replace, at its option, that part of the Product which is shown to be defective. All other RBI supplied Boiler/Water Heater parts are warranted against defects in material and workmanship for one (1) year from date of installation or 18 months from date of shipment from RBI.

The "Manufacturer" warrants to the original owner at the original installation site that the heat exchanger of the Industrial, Commercial, and other Non-Residential Use Water Heater (the "Product") will be free from defects in material or workmanship for five (5) years from the date of installation. Additional twenty one (21) year thermal warranty on heat exchanger. If upon examination by the Manufacturer the Product is shown to have a defect in material or workmanship during the warranty period, the Manufacturer will repair or replace, at its option, that part of the Product which is shown to be defective. All other RBI supplied Boiler/Water Heater parts are warranted against defects in material and workmanship for one (1) year from date of installation or 18 months from date of shipment from RBI.

This limited warranty does not apply:

- (a) if the Product has been subjected to misuse or neglect, has been accidentally or intentionally damaged, has not been installed, maintained or operated in accordance with the furnished written instructions, or has been altered or modified in any way.

These include but not limited to:

- Excessive water hardness causing a lime build-up in the heat exchanger tubes is not a fault of the equipment and is not covered under the manufacturer's warranty.
 - Excessive pitting and erosion on the inside of the heat exchanger tubes caused by high water velocity through the tubes and is not covered by the manufacturer's warranty. (See Installation Instructions for proper pump performance.)
 - Chemical corrosion, no corrosive chemical (freon, dry cleaning chemicals, degreasing liquids, chlorine or any chemicals that produce hydrochloric acid) can be present in the boiler room as it rapidly destroys the heating equipment and voids the warranty.
 - All copper fin boilers should not operate with a return water temperature less than 110°F, 43°C atmospheric combustion, 125°F, 52°C fan assist combustion. If a lower temperature is required, an external bypass should be installed to prevent condensation. The manufacturer's warranty does not cover damage done by condensation.
- (b) to any expenses, including labor or material, incurred during removal or reinstallation of the Product or parts thereof.
- (c) to damage as a result of settlement, distortion, collapse, or cracking of any foundation area, beams or pipes surrounding the Product.
- (d) to any workmanship of any installer of the Product; or to Products installed outside the continental United States or Canada.

This limited warranty is conditional upon:

- (a) shipment, to the Manufacturer, of that part of the Product thought to be defective. Goods can only be returned with prior written approval from the Manufacturer. All returns must be freight prepaid.
- (b) determination in the reasonable opinion of the Manufacturer that there exists a defect in material or workmanship.

Repair or replacement of any part under this Limited Warranty shall not extend the duration of the warranty with respect to such repaired or replaced part beyond the stated warranty period.

THIS LIMITED WARRANTY IS IN LIEU OF ALL OTHER WARRANTIES, EITHER EXPRESS OR IMPLIED, AND ALL SUCH OTHER WARRANTIES, INCLUDING WITHOUT LIMITATION IMPLIED WARRANTIES OF MERCHANTABILITY OR FITNESS FOR A PARTICULAR PURPOSE, ARE HEREBY DISCLAIMED AND EXCLUDED FROM THIS LIMITED WARRANTY. IN NO EVENT SHALL THE MANUFACTURER BE LIABLE IN ANY WAY FOR ANY CONSEQUENTIAL, SPECIAL, OR INCIDENTAL DAMAGES OF ANY NATURE WHATSOEVER, OR FOR ANY AMOUNTS IN EXCESS OF THE SELLING PRICE OF THE PRODUCT OR ANY PARTS THEREOF FOUND TO BE DEFECTIVE. THIS LIMITED WARRANTY GIVES THE ORIGINAL OWNER OF THE PRODUCT SPECIFIC LEGAL RIGHTS. YOU MAY ALSO HAVE OTHER RIGHTS WHICH MAY VARY BY EACH JURISDICTION.



260 North Elm Street
Westfield, MA 01085
Phone: (413) 568-9571
Fax: (413) 568-9613

7555 Tranmere Drive
Mississauga, Ontario L5S 1L4
Phone: (905) 670-5888
Fax: (905) 670-5782



www.rbiwaterheaters.com



260 North Elm Street
Westfield, MA 01085
Phone: (413) 568-9571
Fax: (413) 568-9613

■ 7555 Tranmere Drive
Mississauga, Ontario L5S 1L4
Phone: (905) 670-5888
Fax: (905) 670-5782

