

INSTALLATION INSTRUCTIONS AND PARTS LIST TUBULAR GAS FIRED DIRECT SPARK PROPELLER UNIT HEATERS

ATTENTION: READ THIS MANUAL AND ALL LABELS ATTACHED TO THE UNIT CAREFULLY BEFORE ATTEMPTING TO INSTALL, OPERATE OR SERVICE THESE UNITS! CHECK UNIT DATA PLATE FOR TYPE OF GAS AND ELECTRICAL SPECIFICATIONS AND MAKE CERTAIN THAT THESE AGREE WITH THOSE AT THE POINT OF INSTALLATION. RECORD THE UNIT MODEL AND SERIAL No.(s) IN THE SPACE PROVIDED. RETAIN FOR FUTURE REFERENCE.

Model No. _____ Serial No. _____

FOR YOUR SAFETY

The use and storage of gasoline or other flammable vapors and liquids in open containers in the vicinity of this appliance is hazardous.



FOR YOUR SAFETY

- If you smell gas:
1. Open windows.
 2. Don't touch electrical switches.
 3. Extinguish any open flame.
 4. Immediately contact your gas supplier.

▲ WARNING Improper installation, adjustment, alteration, service, or maintenance can cause property damage, injury, or death. Read the installation, operating, and maintenance instruction thoroughly before installing or servicing this equipment.

APPROVED FOR USE IN CALIFORNIA

▲ WARNING Install, operate, and maintain unit in accordance with the manufacturer's instructions to avoid exposure to fuel substances, or substances from incomplete combustion, which can cause death or serious illness. The state of California has determined that these substances may cause cancer, birth defects, or other reproductive harm.

INSTALLER'S RESPONSIBILITY

Installer Please Note: This equipment has been test fired and inspected. It has been shipped free from defects from our factory. However, shipment and installation problems such as loose wires, leaks, or loose fasteners may occur. **It is the installer's responsibility to inspect and correct any problem that may be found.**

RECEIVING INSTRUCTIONS

Inspect shipment immediately when received to determine if any damage has occurred to the unit during shipment. After the unit has been uncrated, check for any visible damage to the unit. If any damage is found, the consignee should sign the bill of lading indicating such damage and immediately file claim for damage with the transportation company.

TABLE OF CONTENTS

SPECIFICATIONS	ELECTRICAL CONNECTIONS	9, 10
Basic Description	VENTING	11, 12, 13, 14, 15, 16
Performance & Specification Data	OPERATION	
GENERAL SAFETY INFORMATION	Explanation of Controls and Operation	17
Installation Codes	Main Burner Orifice Schedule	18
Special Precautions	Adjustments	18
INSTALLATION	MAINTENANCE	
Locating Units	Servicing & Cleaning	19
Combustion Air	TROUBLESHOOTING GUIDE	20, 21, 22, 23
Proper Clearances	IDENTIFICATION OF PARTS	24, 25, 26
Suspension of Units	WARRANTY	27
Gas Supply Piping	INSPECTION SHEET	28

NOTICE: It is the equipment owners responsibility to provide any scaffolding or other apparatus required to perform emergency service or annual/periodic maintenance to this equipment.

DESCRIPTION

The Tubular Gas Fired Unit Heater is a factory assembled, power vented, low static pressure type propeller fan unit heater designed to be suspended within the space to be heated. THESE HEATERS ARE NOT TO BE CONNECTED TO DUCTWORK. The

designs are certified by ETL as providing a minimum of 80% thermal efficiency, and approved for use in California. **Do not alter these units in any way.** If you have any questions after reading this manual, contact the manufacturer.

Figure 1 - Tubular 30 thru 90 Propeller Unit Heaters



See Identification of Parts throughout this manual.

The following terms are used throughout this manual, in addition to the ETL requirements to bring attention to the presence of potential hazards, or to important information concerning the product:

▲ DANGER Indicates an imminently hazardous situation which, if not avoided, will result in death, serious injury, or substantial property damage.

▲ WARNING Indicates an imminently hazardous situation which, if not avoided, could result in death, serious injury, or substantial property damage.

▲ CAUTION Indicates an imminently hazardous situation which, if not avoided, may result in minor injury or property damage.

NOTICE: Used to notify of special instructions on installation, operation, or maintenance which are important to equipment but not related to personal injury.

GENERAL SAFETY INFORMATION

▲ WARNING Failure to comply with the general safety information may result in extensive property damage, severe personal injury, or death.

▲ WARNING This product must be installed by a licensed plumber or gas fitter when installed with the Commonwealth of Massachusetts.

Installation must be made in accordance with local codes, or in absence of local codes, with the latest edition of ANSI Standard Z223.1 (N.F.P.A. No.54) National Fuel Gas Code. All of the ANSI and NFPA Standards referred to in these installation instructions are those that were applicable at the time the design of this appliance was certified. The NFPA Standards are available from the National Fire Protection Association, Batterymarch Park, Quincy, MA 02269. These unit heaters are designed for use in airplane hangars when installed in accordance with ANSI/NFPA No. 409, and in public garages when installed in accordance with NFPA No. 88A and NFPA No.88B.

If installed in Canada, the installation must conform with local building codes, or in the absence of local building codes, with CGA-B149.1 "Installation Codes for Natural Gas Burning Appliances and Equipment" or CGA-B149.2 "Installation Codes for Propane Gas Burning Appliances and Equipment." These unit heaters have been designed and certified to comply with CGA 2.6. Also see sections on installation in AIRCRAFT HANGARS and PUBLIC GARAGES.

▲ WARNING Do not alter the unit heater in any way or damage to the unit and/or severe personal injury or death may occur!

▲ WARNING Disconnect all power and gas supplies before installing or servicing the heater. If the power disconnect is out of sight, lock it in the open position and tag it to prevent unexpected application of power. Failure to do so could result in fatal electric shock, or severe personal injury.

▲ CAUTION Ensure that all power sources conform to the requirements of the unit heater, or damage to the unit will result!

Follow installation instructions CAREFULLY to avoid creating unsafe conditions. All wiring should be done and checked by a qualified electrician, using copper wire only. All gas connections should be made and leak-tested by a suitably qualified individual, per instructions in this manual. Also follow procedures listed on "Gas Equipment Start-Up Sheet" located in this manual.

Use only the fuel for which the heater is designed (see rating plate). Using LP gas in a heater that requires natural gas, or vice versa, will create risk of gas leaks, carbon monoxide poisoning, and explosion.

▲ WARNING Do not attempt to convert the heater for use with a fuel other than the one intended. Such conversion is dangerous, as it will create the risks previously listed.

Make certain that the power source conforms to the electrical requirements of the heater.

▲ WARNING Do not depend upon a thermostat or other switch as sole means of disconnecting power when installing or servicing heater. Always disconnect power at main circuit breaker as described above. Failure to do so could result in fatal electric shock.

Special attention must be given to any grounding information pertaining to this heater. To prevent the risk of electrocution, the heater must be securely and adequately grounded. This should be accomplished by connecting a ground conductor between the service panel and the heater. To ensure a proper ground, the grounding means must be tested by a qualified electrician.

Do not insert fingers or foreign objects into heater or its air moving device. Do not block or tamper with the heater in any manner while in operation, or just after it has been turned off, as some parts may be hot enough to cause injury.

This heater is intended for general heating applications ONLY. It must NOT be used in potentially dangerous locations such as flammable, explosive, chemical-laden, or wet atmospheres.

Do not attach ductwork to this product or use it as a makeup air heater. Such usage voids the warranty and will create unsafe operation.

In cases in which property damage may result from malfunction of the heater, a back-up system or temperature sensitive alarm should be used.

▲ CAUTION The open end of piping systems being purged shall not discharge into areas where there are sources of ignition or into confined spaces UNLESS precautions are taken as follows: (1) by ventilation of the space, (2) control of the purging rate, (3) elimination of all hazardous conditions. All precautions must be taken to perform this operation in a safe manner!

Unless otherwise specified, the following conversions may be used for calculating SI unit measurements:

1 foot = 0.305 m	1000 BTU/cu. ft. = 37.5 MJ/m ³
1 inch = 25.4 mm	1000 BTU per hour = 0.293 kW
1 gallon = 3.785 L	1 inch water column = 0.249 kPa
1 pound = 0.453 kg	litres/second = CFM x 0.472
1 psig = 6.894 kPa	meters/second = FPM ÷ 196.8
1 cubic foot = 0.028m ³	

Table 1 - Performance and Dimensional Data - Tubular 30 thru 90 Propeller Unit Heater

Unit Size	30	45	60	75	90
PERFORMANCE DATA†					
Input - BTU/Hr.	30,000	45,000	60,000	75,000	90,000
(kW)	(8.8)	(13.2)	(17.6)	(22.0)	(26.4)
Output - BTU/Hr.	24,300	36,450	48,600	60,750	72,900
(kW)	(7.1)	(10.7)	(14.2)	(17.8)	(21.4)
Thermal Efficiency (%)	81	81	81	81	81
Free Air Delivery - CFM	500	750	1,000	1,250	1,500
(cu. m/s)	(0.236)	(0.355)	(0.473)	(0.591)	(0.710)
Air Temperature Rise - Deg. F	45	45	45	45	45
(Deg. C)	(25)	(25)	(25)	(25)	(25)
Full Load Amps at 120V	3.0	3.0	3.7	3.7	4.8
MOTOR DATA: Motor HP					
	1/20	1/20	1/20	1/20	1/20
Motor (kW)	(0.04)	(0.04)	(0.04)	(0.04)	(0.04)
Motor Type	SP	SP	SP	SP	SP
R.P.M.	1650	1650	1050	1050	1050
Motor Amps @ 115V	1.9	1.9	2.6	2.6	2.6
DIMENSIONAL DATA - inches (mm)					
"A" Jacket Height	12 (305)	12 (305)	17-3/4 (451)	17-3/4 (451)	17-3/4 (451)
"B" Overall Height	13 (330)	13 (330)	18-3/4 (476)	18-3/4 (476)	18-3/4 (476)
"C" Overall Depth	25-1/2 (648)	25-1/2 (648)	26-3/4 (679)	26-3/4 (679)	26-3/4 (679)
"Center Line" Height of Flue*	7-1/4 (184)	7-1/4 (184)	10-1/2 (267)	10-1/2 (267)	10-1/2 (267)
"Center Line" Electric Connection	10-1/4 (260)	10-1/4 (260)	16 (406)	16 (406)	16 (406)
"F" Discharge Opening Height	10-1/2 (267)	10-1/2 (267)	16-1/4 (413)	16-1/4 (413)	16-1/4 (413)
"G" Fan Diameter-in	10	10	16	16	16
Unit Weight - lbs.	62	68	87	93	95
(kgs)	(28)	(31)	(39)	(42)	(43)
Shipping Weight - lbs.	72	78	102	108	110
(kgs)	(33)	(35)	(46)	(49)	(50)

* For all installations, the flue collar is included with the unit and should be field installed per the instructions included with the unit.

† Ratings shown are for unit installations at elevations between 0 and 2,000 ft (0 to 610m). For unit installations in U.S.A. above 2,000 ft. (610m), the unit input must be derated 4% for each 1,000 ft. (305m) above sea level; refer to local codes, or in absence of local codes, refer to the National Fuel Gas Code or the latest edition of ANSI Standard Z223.1 (N.F.P.A. No. 54).

For installations in Canada, any reference to deration at altitudes in excess of 2,000 ft. (610m) are to be ignored. At altitudes of 2,000 ft. to 4,500 ft. (610 to 1372m), the unit must be derated to 90% of the normal altitude rating, and be so marked in accordance with the ETL certification.

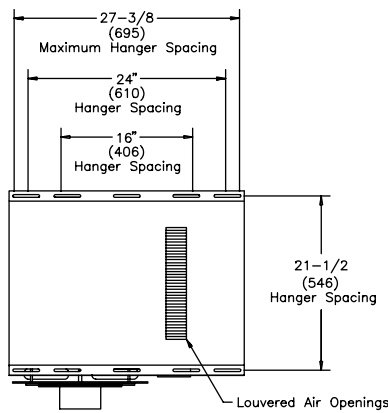

Top View

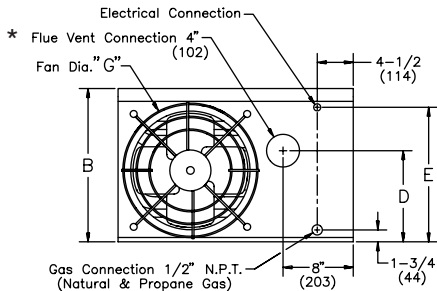

Rear View

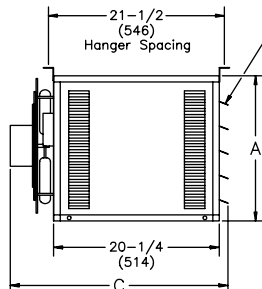

Side View

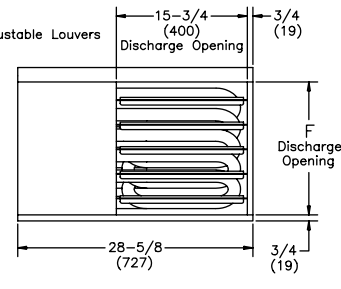

Front View

D4771

DIMENSIONS .XXX STANDARD UNITS
DIMENSIONS IN PARENTHESIS (XXX) MILLIMETERS

Figure 2 - Dimensional Drawing – Tubular 30 thru 90 Propeller Unit Heater

INSTALLATION

▲ WARNING Do not install unit heaters in corrosive or flammable atmospheres! Premature failure of, or severe damage to the unit will result!

▲ WARNING Avoid locations where extreme drafts can affect burner operation. Unit heaters must not be installed in locations where air for combustion would contain chlorinated, halogenated or acidic vapors. If located in such an environment, premature failure of the unit will occur!

Since the unit is equipped with an automatic gas ignition system, the unit heater must be installed such that the gas ignition control system is not directly exposed to water spray, rain or dripping water.

NOTICE: Location of unit heaters is related directly to the selection of sizes. Basic rules are as follows:

MOUNTING HEIGHT: Unit Heaters equipped with standard fan guards must be installed at a minimum of 8 feet (2.4m) above the floor, measured to the bottom of the unit. At heights above 8 feet (2.4m), less efficient air distribution will result. **If a unit is to be mounted below eight feet (2.4m) from the floor, an OSHA approved fan guard is required on the unit.**

AIRCRAFT HANGARS: Unit Heaters must be installed in aircraft hangars as follows: In aircraft hangars, unit heaters must be at least 10 feet (3.0m) above the upper surface of wings or engine enclosures of the highest aircraft to be stored in the hangar, and 8 feet (2.4m) above the floor in shops, offices and other sections of the hangar where aircraft are not stored or housed. Refer to current ANSI/NFPA No. 409, Aircraft Hangars. In Canada, installation is suitable in aircraft hangars when acceptable to the enforcing authorities.

PUBLIC GARAGES: In repair garages, unit heaters must be at least 8 feet (2.4m) above the floor. Refer to the latest edition of NFPA No. 88B, Repair Garages.

In parking structures, unit heaters must be installed so that the burner flames are located a minimum of 18 inches (457mm) above the floor or protected by a partition not less than 18 inches (457mm) high. However, any unit heater mounted in a parking structure less than 8 ft. (2.4m) above the floor must be equipped with an OSHA approved fan guard. Refer to the latest edition of NFPA 88A, Parking Structures.

In Canada, installation must be in accordance to the latest edition of CGA B149 "Installation Codes for Gas Burning Appliances and Equipment."

AIR DISTRIBUTION: Direct air towards areas of maximum heat loss. When multiple heaters are involved, circulation of air around the perimeter is recommended where heated air flows along exposed walls. Satisfactory results can also be obtained where multiple heaters are located toward the center of the area with heated air directed toward the outside walls. Be careful to avoid all obstacles and obstructions which could impede the warm air distribution patterns.

Unit heaters should not be installed to maintain low temperatures and/or freeze protection of buildings. A minimum of 50°F (10°C) thermostat setting must be maintained. If unit heaters are operated to maintain lower than 50°F (10°C), hot flue gases are cooled inside the heat exchanger to a point where water vapor (a flue gas by-product) condenses onto the heat exchanger walls. The result is a mildly corrosive acid that prematurely corrodes the aluminized heat exchanger and can actually drip water down from the unit heater onto floor surface. Additional unit heaters should be installed if a minimum 50°F (10°C) thermostat setting cannot be maintained.

AIR FOR COMBUSTION: The unit heater shall be installed in a location in which the facilities for ventilation permit satisfactory combustion of gas, proper venting, and the maintenance of ambient air at safe limits under normal conditions of use. The unit heater shall be located in such a manner as not to interfere with proper circulation of air within the confined space. When buildings are so tight that normal infiltration does not meet air requirements, outside air shall be introduced per Sections 1.3.4.2 and 1.3.4.3 of ANSI Z223.1 for combustion requirements. A permanent opening or openings having a total free area of not less than one square inch per 5,000 BTU/Hr (1.5 kW) of total input rating of all appliances within the space shall be provided.

NOTICE: Unit Heater sizing should be based on heat loss calculations where the unit heater output equals or exceeds heat loss.

CLEARANCES: Each Gas Unit Heater shall be located with respect to building construction and other equipment so as to permit access to the Unit Heater. Clearance between vertical walls and the vertical sides of the Unit Heater shall be no less than 1 inch (25.4mm). However, to ensure access to the fan and control box, a minimum of 18" (457mm) is required for the fan and control box side. A minimum clearance of 1 inch (25.4mm) must be maintained between the top of the Unit Heater and the ceiling. The bottom of the Unit Heater must be no less than 1 inch (25.4mm) from any combustible. The distance between the flue collector and any combustible must be no less than 1 inch (25.4mm). Also see AIR FOR COMBUSTION and VENTING sections.

NOTICE: Increasing the clearance distances may be necessary if there is a possibility of distortion or discoloration of adjacent materials.

INSTALLATION (continued)

MOUNTING: The Unit Heater may be mounted with the vent outlet, gas and electrical connections to the right or left of the air moving fan. The Unit Heater is shipped with the connections to the right of the fan when looking in the direction of the air flow. If connections to the left are required, remove the hanging brackets, invert the unit (180°), and re-install the hanging brackets. Remove, invert, and replace the control access panel and the air discharge louvers.

The Unit Heater may be mounted by fastening the hanging brackets directly to ceiling joists or by suspending from four rods. See Figures 3A, 3B and 3C.

▲ WARNING Make certain that the lifting methods used to lift the heater and the method of suspension used in the field installation of the heater are capable of uniformly supporting the weight of the heater at all times. Failure to heed this warning may result in property damage or personal injury!

▲ WARNING Make sure that the structure to which the unit heater is to be mounted is capable of safely supporting its weight. Under no circumstances must the gas lines, the venting system or the electrical conduit be used to support the heater; or should any other objects (i.e. ladder, person) lean against the heater gas lines, venting system or the electrical conduit for support. Failure to heed these warnings may result in property damage, personal injury, or death.

▲ CAUTION Unit Heaters must be hung level from side to side and from front to back, see Figures 3A, 3B and 3C. Failure to do so will result in poor performance and/or premature failure of the unit.

▲ WARNING Ensure that all hardware used in the suspension of each unit heater is more than adequate for the job. Failure to do so may result in extensive property damage, severe personal injury, or death!

Refer to Figures 3A, 3B and 3C for suspension of units.

Figure 3A - Hanger Bracket Installation Instructions

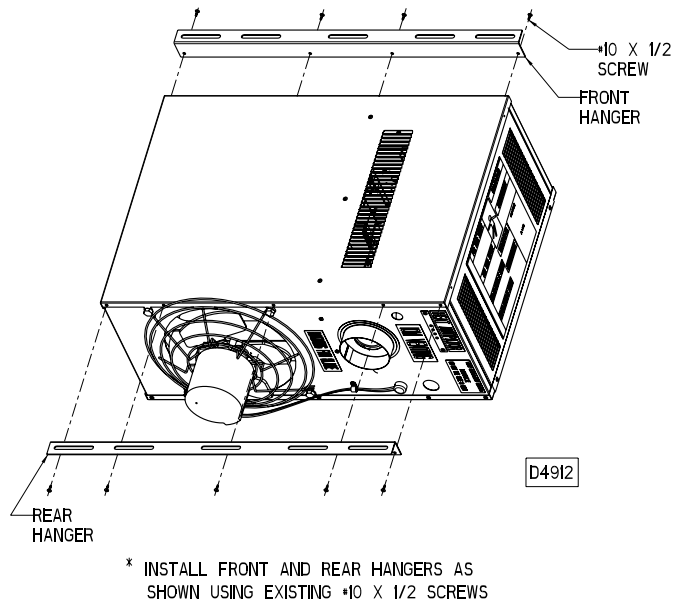

Figure 3B - Heater Mounting (Steel Construction)

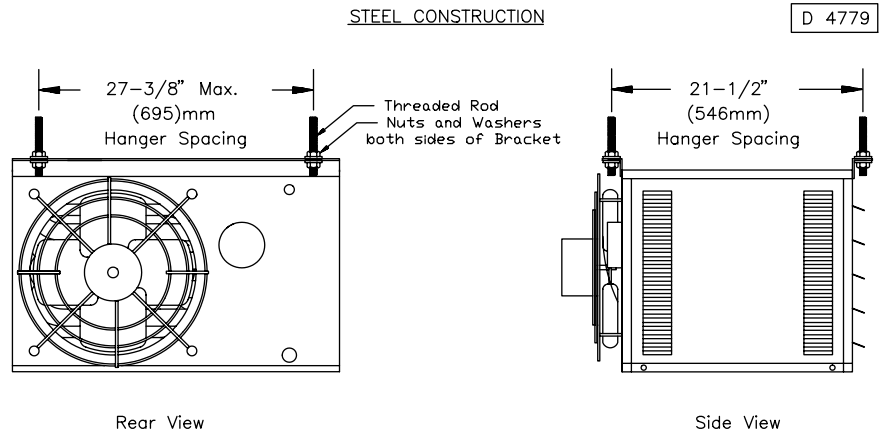
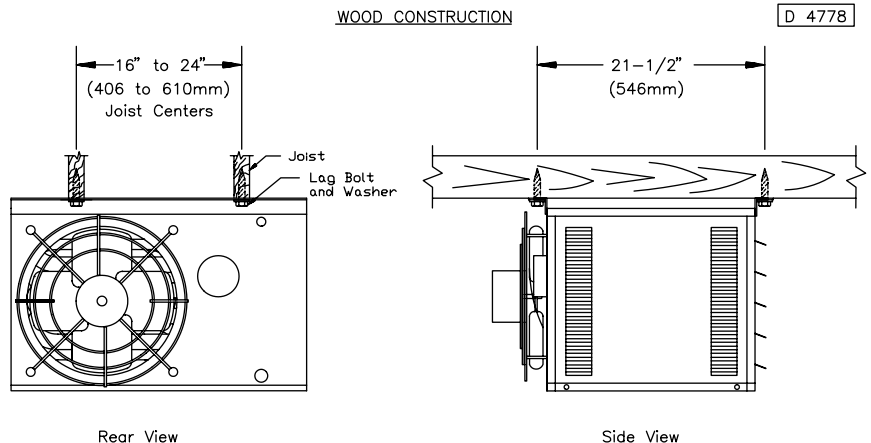

Figure 3C - Heater Mounting (Wood Construction)



GAS PIPING

▲ WARNING To avoid damage or possible personal injury, do not connect gas piping to this unit until a supply line pressure/leak test has been completed. Connecting the unit before completing the pressure/leak test may damage the unit gas valve and result in a fire hazard.

▲ WARNING Do not rely on a shut-off valve to isolate the unit while conducting gas pressure/leak tests. These valves may not be completely shut off, exposing the gas valve to excessive pressure and damage.

PIPE SIZING

To provide adequate gas pressure to the gas unit heater, size the gas piping as follows:

- Find the cu. ft./hr. by using the following formula:

$$\text{Cu. ft./hr.} = \frac{\text{Input}}{\text{BTU}}$$

- Refer to Table 2. Match "Length of Pipe in Feet" with appropriate "Gas Input - Cu. Ft./Hr." figure. This figure can then be matched to the pipe size at the top of the column.

Example:

It is determined that a 67 foot (20.4m) run of gas pipe is required to connect a 75 MBTU gas unit heater to a 1,000 BTU/cu ft. (0.29kW) natural gas supply.

$$\frac{75,000 \text{ BTU/Hr}}{1,000 \text{ BTU/cu. ft.}} = 75 \text{ Cu. ft./hr.}$$

Using Table 2, a 3/4 inch pipe is needed.

NOTE: See General Safety Information section for English/Metric unit conversion factors.

NOTICE: If more than one unit heater is to be served by the same piping arrangement, the total cu. ft./hr. input and length of pipe must be considered.

NOTICE: If the gas unit heater is to be fired with LP gas, consult your local LP gas dealer for pipe size information.

NOTICE: HEATER INSTALLATION FOR USE WITH PROPANE (BOTTLED) GAS MUST BE MADE BY A QUALIFIED L.P. GAS DEALER OR INSTALLER. HE WILL INSURE THAT PROPER JOINT COMPOUNDS ARE USED FOR MAKING PIPE CONNECTIONS; THAT AIR IS PURGED FROM LINES; THAT A THOROUGH TEST IS MADE FOR LEAKS BEFORE OPERATING THE HEATER; AND THAT IT IS PROPERLY CONNECTED TO THE PROPANE GAS SUPPLY SYSTEM.

Before any connection is made to the existing line supplying other gas appliances, contact the local gas company to make sure that the existing line is of adequate size to handle the combined load.

Table 2 - Gas Pipe Size

Maximum Capacity of Pipe in Cubic Feet of Gas per Hour (Cubic Meters per Hour) for Gas Pressures of 0.5 psig (3.5 kPa) or Less, and a Pressure Drop of 0.5 Inch Water Column (124.4 Pa)
(Based on a 0.60 Specific Gravity Gas)

Nominal Iron Pipe Size	Internal Dia. in.	Length of Pipe, Feet (meters)														
		10 (3.0)	20 (6.1)	30 (9.1)	40 (12.2)	50 (15.2)	60 (18.3)	70 (21.3)	80 (24.4)	90 (27.4)	100 (30.5)	125 (38.1)	150 (45.7)	175 (53.3)	200 (61.0)	
1/2	0.622	175 (4.96)	120 (3.40)	97 (2.75)	82 (2.32)	73 (2.07)	66 (1.87)	61 (1.73)	57 (1.61)	53 (1.50)	50 (1.42)	44 (1.25)	40 (1.13)	37 (1.05)	35 (0.99)	
3/4	0.824	360 (10.2)	250 (7.08)	200 (5.66)	170 (4.81)	151 (4.28)	138 (3.91)	125 (3.54)	118 (3.34)	110 (3.11)	103 (2.92)	93 (2.63)	84 (2.38)	77 (2.18)	72 (2.04)	
1	1.049	680 (19.3)	465 (13.2)	375 (10.6)	320 (9.06)	285 (8.07)	260 (7.36)	240 (6.80)	220 (6.23)	205 (5.80)	195 (5.52)	175 (4.96)	160 (4.53)	145 (4.11)	135 (3.82)	
1 1/4	1.380	1400 (39.6)	950 (26.9)	770 (21.8)	660 (18.7)	580 (16.4)	530 (15.0)	490 (13.9)	460 (13.0)	430 (12.2)	400 (11.3)	360 (10.2)	325 (9.20)	300 (8.50)	280 (7.93)	
1 1/2	1.610	2100 (59.5)	1460 (41.3)	1180 (33.4)	990 (28.0)	900 (25.5)	810 (22.9)	750 (21.2)	690 (19.5)	650 (18.4)	620 (17.6)	550 (15.6)	500 (14.2)	460 (13.0)	430 (12.2)	
2	2.067	3950 (112)	2750 (77.9)	2200 (62.3)	1900 (53.8)	1680 (47.6)	1520 (43.0)	1400 (39.6)	1300 (36.8)	1220 (34.5)	1150 (32.6)	1020 (28.9)	950 (26.9)	850 (24.1)	800 (22.7)	
2 1/2	2.469	6300 (178)	4350 (123)	3520 (99.7)	3000 (85.0)	2650 (75.0)	2400 (68.0)	2250 (63.7)	2050 (58.0)	1950 (55.2)	1850 (52.4)	1650 (46.7)	1500 (42.5)	1370 (38.8)	1280 (36.2)	
3	3.068	11000 (311)	7700 (218)	6250 (177)	5300 (150)	4750 (135)	4300 (122)	3900 (110)	3700 (105)	3450 (97.7)	3250 (92.0)	2950 (83.5)	2650 (75.0)	2450 (69.4)	2280 (64.6)	
4	4.026	23000 (651)	15800 (447)	12800 (362)	10900 (309)	9700 (275)	8800 (249)	8100 (229)	7500 (212)	7200 (204)	6700 (190)	6000 (170)	5500 (156)	5000 (142)	4600 (130)	

1. Determine the required Cu. Ft./Hr. by dividing the input by 1000. For SI/Metric measurements: Convert BTU/Hr. to kilowatts. Multiply the units inputs (kW) by 0.0965 to determine Cu. Meters./Hr. 2. FOR NATURAL GAS: Select pipe size directly from the table. 3. FOR PROPANE GAS: Multiply the Cu. Ft./Hr. value by 0.633; then use the table. 4. Refer to the metric conversion factors listed in the General Safety section for SI Unit measurement conversions.

PIPE INSTALLATION

1. Install the gas piping in accordance with applicable local codes.
2. Check gas supply pressure. Each unit heater must be connected to a gas supply capable of supplying its full rated capacity at a pressure not less than 5 in. W.C. (1.2 kPa), and not greater than 14 in. W.C. (3.5 kPa) for natural gas. The manifold pressure for natural gas must be 3.5 in. W.C. (0.9 kPa) under normal conditions. For propane gas operation, the manifold pressure must be 10 in. W.C. (2.5 kPa). For propane (LP) gas, the minimum supply pressure must be 11 in. W.C. (2.7 kPa). A field LP tank regulator must be used to limit the supply pressure to a maximum of 14 in. W.C. (3.5 kPa). All piping should be sized in accordance with the latest edition of ANSI Standard Z223.1 National Fuel Gas Code; in Canada, according to CGA B149. See Figure 2 and Tables 1 & 2 for correct gas piping size. If gas pressure is excessive on natural gas applications, install a pressure regulating valve in the line upstream from the main shutoff valve.
3. Adequately support the piping to prevent strain on the gas manifold and controls.
4. To prevent the mixing of moisture with gas, run the take-off piping from the top, or side, of the main.
5. Standard Unit Heaters, optional two-stage units are supplied with a combination valve which includes:
 - a. Manual "A" valve
 - b. Manual "B" valve
 - c. Solenoid valve
 - d. Pressure regulator
 Pipe directly into the combination valve (see Figure 4).
6. Gas valve has pressure test post requiring a 3/32" hex head wrench to read gas supply and manifold pressures. Open 1/4 turn counterclockwise to read, turn clockwise to close and reseal. A 5/16" ID hose fits the pressure post.
7. Provide a drip leg in the gas piping near the gas unit heater. A ground joint union and a manual gas shutoff valve should be installed ahead of the unit heater controls to permit servicing. The manual shutoff valve must be located external to the jacket. (See Figure 4)
8. Make certain that all connections have been adequately doped and tightened.

▲ CAUTION Do not over tighten the inlet gas piping into the valve. This may cause stresses that will crack the valve!

NOTICE: Use pipe joint sealant resistant to the action of liquefied petroleum gases regardless of gas conducted.

▲ WARNING Check all pipe joints for leakage using a soap solution or other approved method. Never use an open flame or severe personal injury or death may occur!

Figure 4 - Pipe Installation, Standard Controls

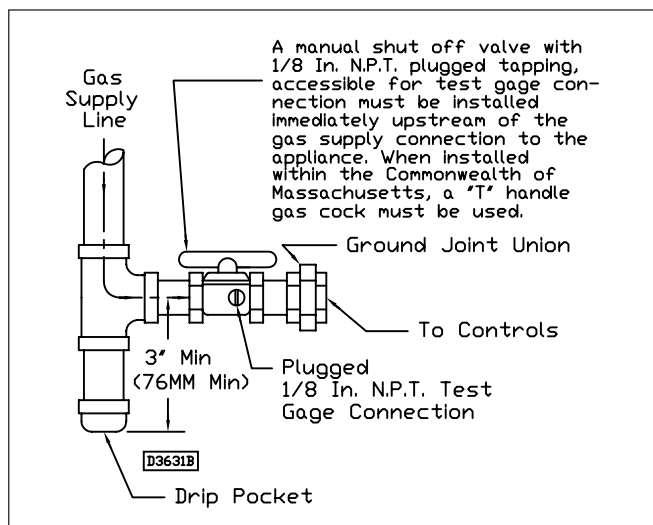

▲ WARNING Never use an open flame to detect gas leaks. Explosive conditions may exist which may result in personal injury or death!

The appliance and its individual shutoff valve must be disconnected from the gas supply piping system during any pressure testing of that system in excess of 1/2 psig (3.5 kPa).

The appliance must be isolated from the gas supply piping system by closing its individual manual shutoff valve during any pressure testing of the gas supply piping system at test pressures equal to or less than 1/2 psig (3.5 kPa).

ELECTRICAL CONNECTIONS



▲ WARNING
HAZARDOUS VOLTAGE!
DISCONNECT ALL ELECTRIC POWER INCLUDING REMOTE DISCONNECTS BEFORE SERVICING. Failure to disconnect power before servicing can cause severe personal injury or death.

Standard units are shipped for use on 115 volt, 60 hertz, single phase electric power. The motor name-plate and electrical rating of the transformer should be checked before energizing the unit heater electrical system. All external wiring must conform to the latest edition of ANSI/NFPA No. 70, National Electrical Code, and applicable local codes; in Canada, to the Canadian Electrical Code, Part 1, CSA Standard C22.1

▲ CAUTION Do not use any tools (i.e. screwdriver, pliers, etc.) across terminals to check for power. Use a voltmeter.

It is recommended that the electrical power supply to each unit heater be provided by a separate, fused, and permanently live electrical circuit. A disconnect switch of suitable electrical rating should be located as close to the gas valve and controls as possible. Each unit heater must be electrically grounded in accordance with the latest edition of the National Electrical Code, ANSI/NFPA No. 70, or CSA Standard C22.1. Refer to Figures 5A, 5B and 5C.

Figure 5A - Low-voltage Thermostat Wiring Single Stage

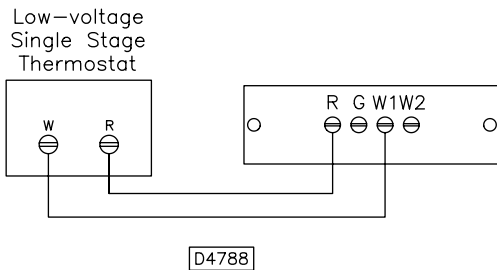
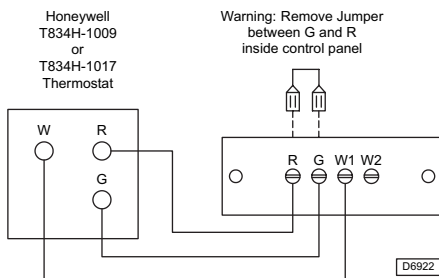

Figure 5B - T834H-1009 or T834H-1017 Thermostat Wiring



THERMOSTAT WIRING AND LOCATION:

NOTICE: The thermostat must be mounted on a vertical, vibration-free surface, free from air currents, and in accordance with the furnished instructions.

Mount the thermostat approximately 5 feet (1.5m) above the floor, in an area where it will be exposed to a free circulation of average temperature air. Always refer to the thermostat instructions, as well as our unit wiring diagram, and wire accordingly. Avoid mounting the thermostat in the following locations:

1. Cold Areas- Outside walls or areas where drafts may affect the operation of the control.
2. Hot Areas- Areas where the sun's rays, radiation, or warm air currents may affect the operation of the control.
3. Dead Areas- Areas where the air cannot circulate freely, such as behind doors or in corners.

THERMOSTAT HEAT ANTICIPATOR ADJUSTMENTS:

The initial heat anticipator setpoint should equal the thermostat's current amperage draw when the unit is firing. This setpoint should be measured for the best results. Use the recommended ranges for a guide. If further information is needed, consult your thermostat manufacturer's instructions.

Recommended Heat Anticipator Settings:

Unit Size:	30 thru 200	250 thru 400
For Tubular Units:	0.35 Amps	0.65 Amps

NOTICE: The start-up fan delay should not exceed 30 seconds from a cold start.

IMPORTANT: For all wiring connections, refer to the wiring diagram shipped with your unit (either affixed to the side jacket or enclosed in the installation instructions envelope). Should any original wire supplied with the heater have to be replaced, it must be replaced with wiring material having a temperature rating of at least 105° C.

Should any high limit wires have to be replaced, they must be replaced with wiring material having a temperature rating of 200° C minimum.

VENTING*

All unit heaters must be vented! All Venting installations shall be in accordance with the latest edition of Part 7, Venting of Equipment of the National Fuel Gas Code, ANSI Z223.1, or applicable provisions of local building codes. Refer to notes* below for Canadian installations. Refer to Figures 6, 9, 9A, 9B, 10A, 10B, 11A and 11B.

▲ WARNING CARBON MONOXIDE! Your venting system must not be blocked by any snow, snow drifts, or any foreign matter. Inspect your venting system to ensure adequate ventilation exists at all times! Failure to heed these warnings could result in Carbon Monoxide Poisoning (symptoms include grogginess, lethargy, inappropriate tiredness, or flu-like symptoms).

When an existing heater is removed or replaced in venting system, the venting system may not be properly sized to vent the attached appliances. An improperly sized vent system can cause formulation of condensate or leakage or spillage of flue gases.

The following steps shall be followed with each appliance connected to the venting system placed in operation, while any other appliances connected to the venting system are not in operation:

1. Seal any unused openings in the venting system;
2. Inspect the venting system for proper size and horizontal pitch, as required in the National Fuel Gas Code, ANSI Z223.1 and these instructions. Determine that there is no blockage or restriction, leakage, corrosion and other deficiencies, which could cause an unsafe condition.
3. In so far as practical, close all building doors and windows and all doors between the space in which the appliance(s) connected to the venting system are located and other spaces of the building. Turn on clothes dryers and any exhaust fans, such as range hoods and bathroom exhausts, so they shall operate at maximum speed. Do not operate a summer exhaust fan. Close fireplace damper.
4. Follow the lighting instructions. Place the appliance being inspected in operation. Adjust thermostat so that the appliance will operate continuously.
5. After it has been determined that each appliance connected to the venting system properly vents when tested as outline above, return doors, windows, exhaust fans, fireplace dampers, and any other gas-burning appliance to their previous condition of use.
6. If improper venting is observed during any of the above tests, the venting system must be corrected immediately so that the system conforms with the National Fuel Gas Code, ANSI Z223.1. When resizing any portion of the venting system, the venting system should be resized to approach the minimum size as determined using the appropriate tables in Appendix G of the National Fuel Gas Code, ANSI Z223.1.

The unit heater shall be connected to a factory built chimney or vent complying with a recognized standard, or a masonry or concrete chimney lined with a lining material acceptable to the authority having jurisdiction. **Venting into an unlined masonry chimney is prohibited.**

ADDITIONAL REQUIREMENTS FOR CANADIAN INSTALLATIONS

*The following instructions apply to Canadian installations in addition to installation and operating instructions.

1. Installation must conform with local building codes, or in the absence of local codes, with current CGA-B149.1, Installation Codes for Natural Gas Burning Appliances and Equipment, or CGA-B149.2, Installation Codes for Propane Gas Burning Appliances and Equipment.
2. Any reference to U.S. standards or codes in these instructions are to be ignored and the applicable Canadian standards or codes applied.

VENTING

ANSI now organizes vented appliances into four categories.

Venting Categories

	Non Condensing	
	Condensing	Condensing
Negative Vent Pressure	I	II
Positive Vent Pressure	III	IV

Category I

Includes non-condensing appliances with negative vent pressure, like the traditional atmospheric unit heater.

Category II

Groups condensing appliances with negative vent pressure.

Category III

Appliances are non-condensing and operate with a positive vent pressure.

Category IV

Covers condensing appliances with positive vent pressure.

NOTICE: Category II and IV do not apply to equipment specified within this manual.

VERTICALLY VENTED UNIT HEATERS (CATEGORY I)

Observe the following precautions when venting the unit: The unit heater shall be connected to a factory built chimney or vent complying with a recognized standard, or a masonry or concrete chimney lined with a lining material acceptable to the authority having jurisdiction.

Venting into an unlined masonry chimney is prohibited.

1. Use flue pipe of the same size as the flue connections on the gas unit heater, 4 inch (102mm). All heaters must be vented with UL Listed Type B vent, or single wall pipe.
2. Provide as long a vertical run of flue pipe at the gas unit heater as possible. A minimum of 5 feet (1.5m) of vertical flue is required. The top of the vent pipe should extend at least 2 feet (0.61m) above the highest point on the roof. Install a weather cap over the vent opening.
3. Slope horizontal runs upward from the gas unit heater at least 1/4-inch per foot (21mm/m) minimum. Horizontal runs should not exceed 33% of the vertical height of the vent pipe, or chimney, above the flue pipe connection, up to a maximum length of 10 feet (3m). Horizontal portions of the venting system shall be supported at maximum intervals of 4 feet (1.22m). (See Figure 6)
4. Use as few elbows as possible.
5. Tape flue pipe joints with high temp, RTV or foil face tape.
6. Avoid running vent pipe through unheated spaces.
7. When this cannot be avoided, insulate the pipe to prevent condensation of moisture on the walls of the pipe. Insulate vent pipe runs longer than 10 feet (3m). Insulation should be a minimum of 1/2 inch (12.7mm) thick foil faced fiberglass, 1-1/2# density insulation.
8. Do not damper the flue piping. Failure to open such a damper prior to operating the gas unit heater will result in the spillage of flue gas into the occupied space.
9. Avoid installing units in areas under negative pressure due to large exhaust fans or air conditioning. When required, a flue vent fan should be installed in accordance with the instructions included with the fan.
10. Vent connectors serving Category I and Category II heaters shall not be connected into any portion of mechanical draft systems operating under positive pressure.
11. Also refer to Figures 10B and 11B for additional requirements.

Figure 6

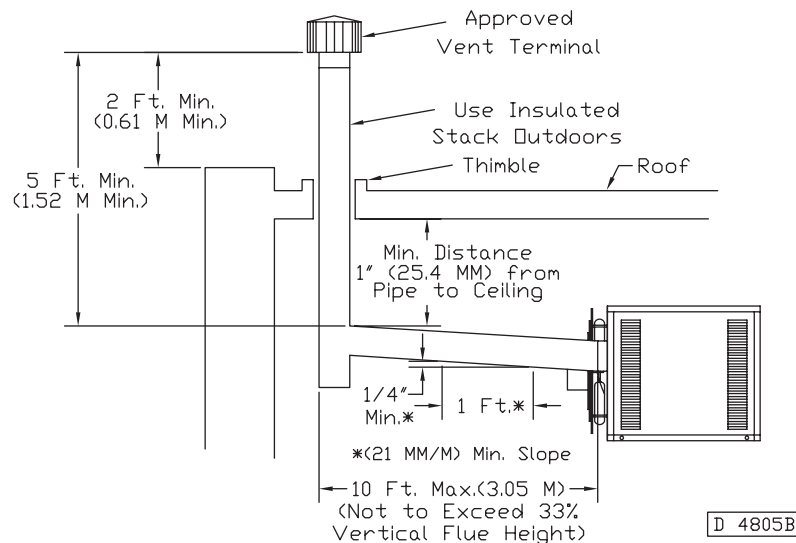

HORIZONTALLY VENTED UNIT HEATERS (CATEGORY III)

All venting of residential tubular unit heaters must comply with the latest edition of CSA .10.96 (2nd ed.) requirement.

Category III horizontal venting arrangements are designed to use single wall vent pipe. These arrangements must terminate external to the building using either single wall or double wall (Type B) vent. See Figures 9, 9A, and 9B for installation requirements regarding these venting conditions. If double wall venting is used, components that are UL Listed and approved for Category III positive pressure venting systems must be used with one exception: a single 5 foot (1.52 M) section of 4 inch (102mm) Type B vent pipe with a draft hood connector may be used between the appliance vent connection and the vent terminal. Use Metalbestos Type B Gas Vent with a Metalbestos 4RV-DH Draft Hood Connector or Amerivent Type B Gas Vent with an Amerivent 4EDC Draft Hood Connector. See Figure 9A. If using a single section of Type B vent pipe, seal the annular space between the inner and outer sections of the draft hood connector with high temperature silicone sealant. See Figure 9B. Attach the draft hood connector to the appliance vent connection with screws and seal the joint with silicone sealant. Install a Type B vent thimble in the wall. Insert the vent pipe through the thimble and attach it to the adapter on the appliance. Seal the joint with silicone sealant or two wraps of aluminum foil tape. Install a vent cap on the outlet of the pipe and secure it with screws.

An Amerivent Americap, Fields Starcap, or Metalbestos vent cap must be supplied by the customer for each power vented unit. The vent pipe diameter MUST be 4 inches (102mm).

Vent Systems Termination Clearance Requirements	
Structure	Minimum Clearances for Termination Locations
Door, window or any gravity air inlet	4 feet below
	4 feet horizontally
	1 foot above
Forced air inlet within 10 ft.	3 feet above
Adjoining building or parapet	6 feet
Adjacent public walkways	7 feet above grade

The venting system for these appliances shall terminate at least 4 feet (1.2m) below, 4 feet (1.2m) horizontal from, or 1 foot (0.3m) above any door, window, or gravity vent air inlet into the building.

The vent terminal must be at least 12 inches (305mm) from the exterior of the wall that it passes through to prevent degradation of the building material by flue gases.

The vent terminal must be at least 1 foot (305mm) above grade, or in snow areas, at least 3 feet above the snow line to prevent blockage by snow.

Through the wall vent for these appliances shall NOT terminate over public walkways, or over an area where the condensate or vapor could create a nuisance or hazard or could be detrimental to the operation of regulators, relief valves, or other equipment.

The vent pipe equivalent length must not exceed 30 feet (9.14m) for the 30 and 45 unit sizes, and 40 feet (12.2m) for the 60, 75 and 90 unit sizes. Equivalent length is the total length of straight sections PLUS 5 feet (1.52m) for each 90 elbow and 2.5 feet (0.76m) for each 45 elbow.

Maintain 1 inch (25.4mm) between the vent pipe and combustible materials.

The vent terminal must be installed with a minimum horizontal clearance of 4 feet (1.2m) from electric meters, gas meters, regulators, and relief equipment.

Seal all vent pipe joints and seams to prevent leakage. Use General Electric RTV-108, Dow-Corning RTV-732, or equivalent silicone sealant with temperature rating of 500°F; or 3M #425 aluminum foil tape (or equivalent). The vent air system must be installed to prevent collection of condensate. Pitch horizontal pipes downward 1/4 inch per foot (21mm per meter) toward the outlet for condensate drainage.

Horizontal portions of the venting systems shall be supported at maximum intervals of 4 feet (1.2m) to prevent sagging (in Canada, support at 3 feet (1m) minimum intervals).

Insulate single wall vent pipe exposed to cold air or running through unheated areas. Insulate vent pipe runs longer than 10 feet (3m). Insulation should be a minimum of 1/2 inch thick foil faced fiberglass, 1-1/2# density insulation.

Each unit must have an individual vent pipe and vent terminal! Each unit MUST NOT be connected to other vent systems or to a chimney.

Figure 9 - Category III Horizontal Venting Requirements Using Single Wall Vent Pipe

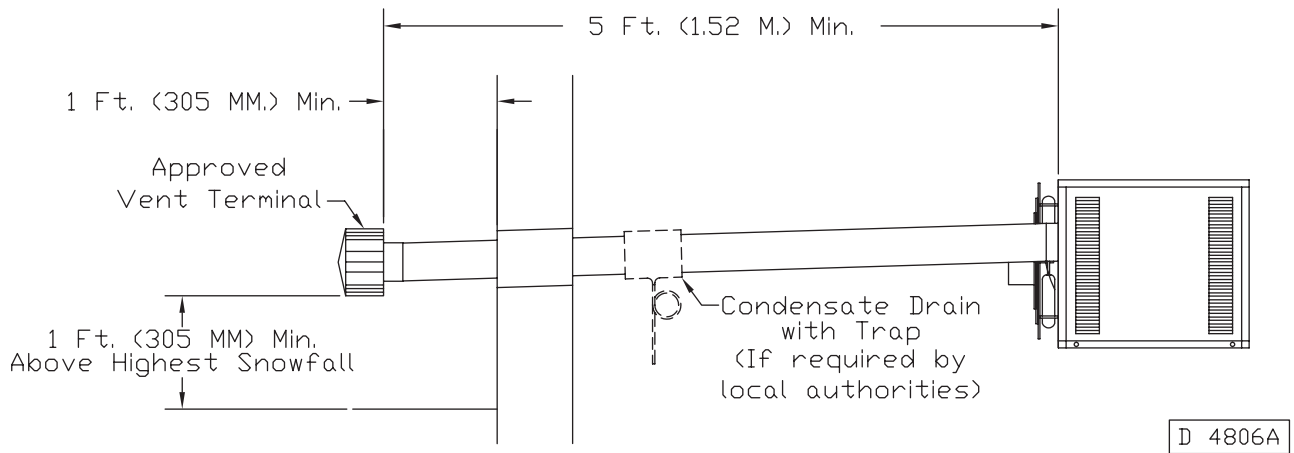

Figure 9A - Category III Horizontal Venting Requirements Using Type B Double Wall Vent Pipe

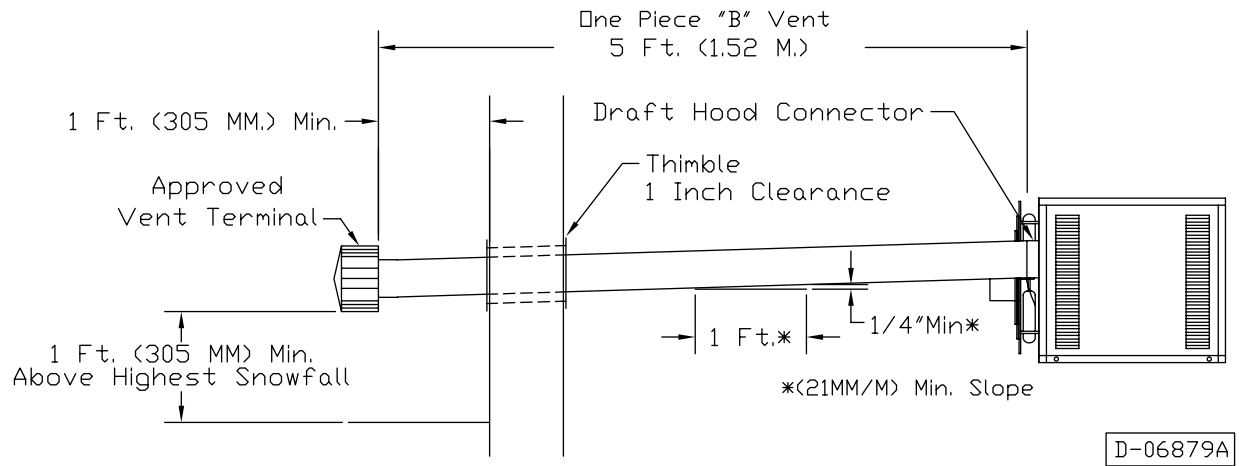
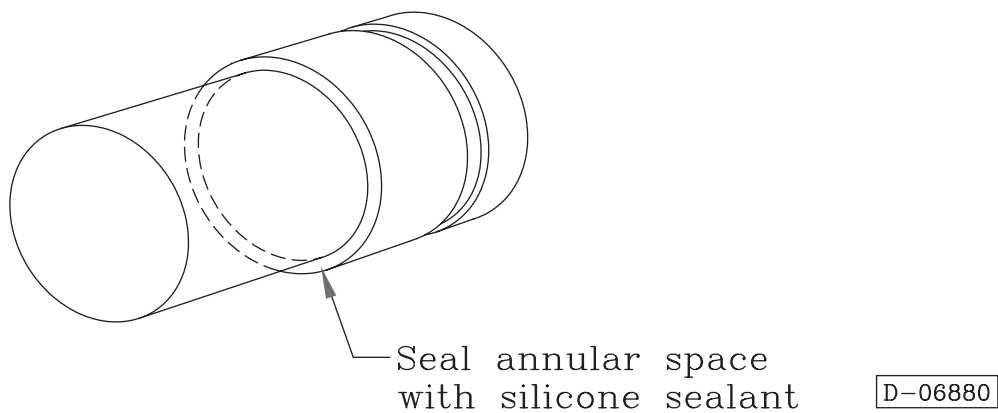

Figure 9B - Type B Draft Hood Connector



VENTING (continued)

Figure 10A

HORIZONTAL ARRANGEMENT SINGLE WALL VENT SYSTEM TO SINGLE WALL TERMINATION

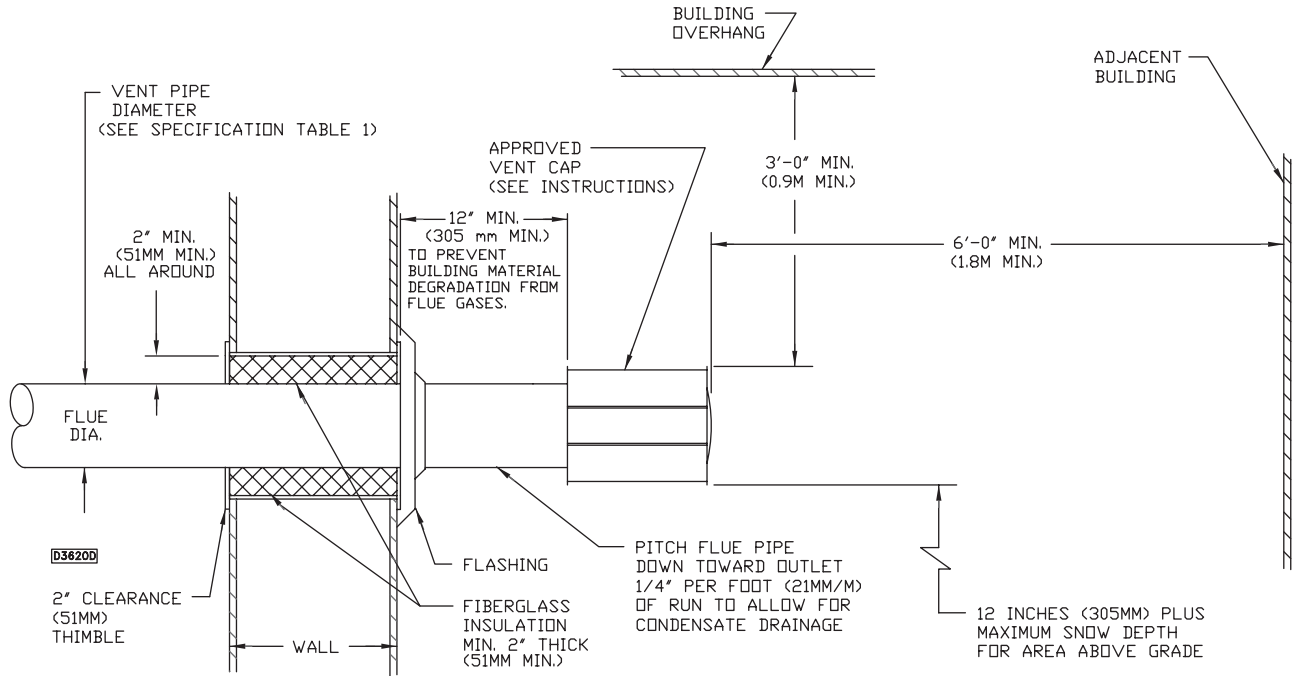
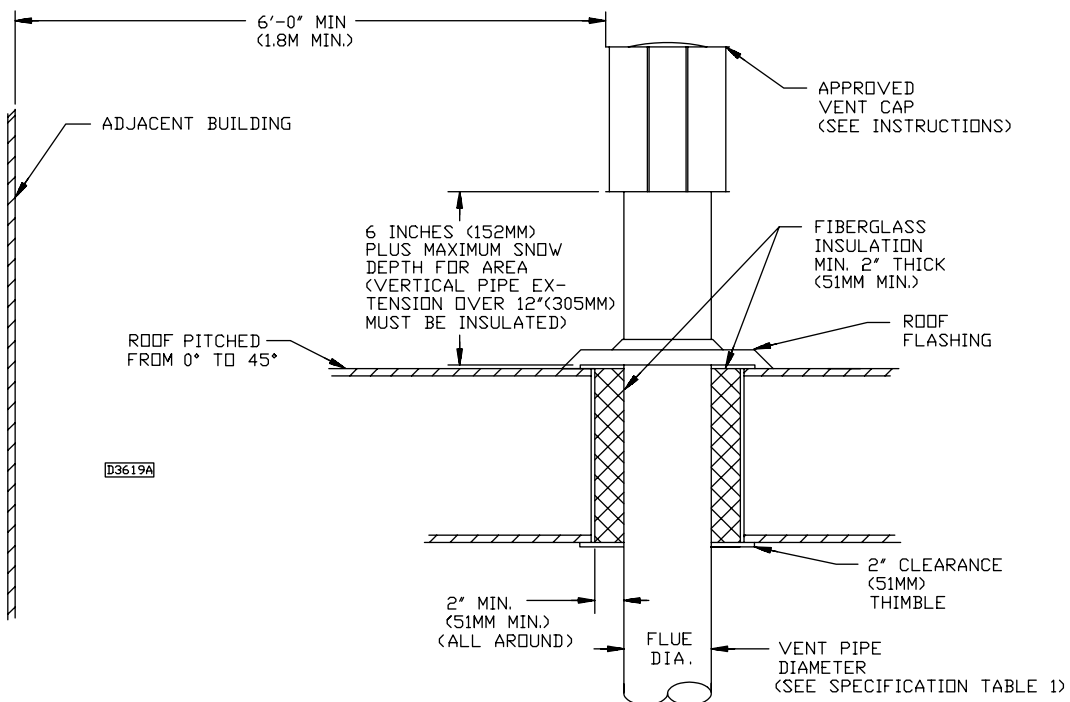

Figure 10B

VERTICAL ARRANGEMENT SINGLE WALL VENT SYSTEM TO SINGLE WALL TERMINATION



VENTING (continued)

Figure 11A

HORIZONTAL ARRANGEMENT

SINGLE WALL VENT SYSTEM TO DOUBLE WALL TERMINATION

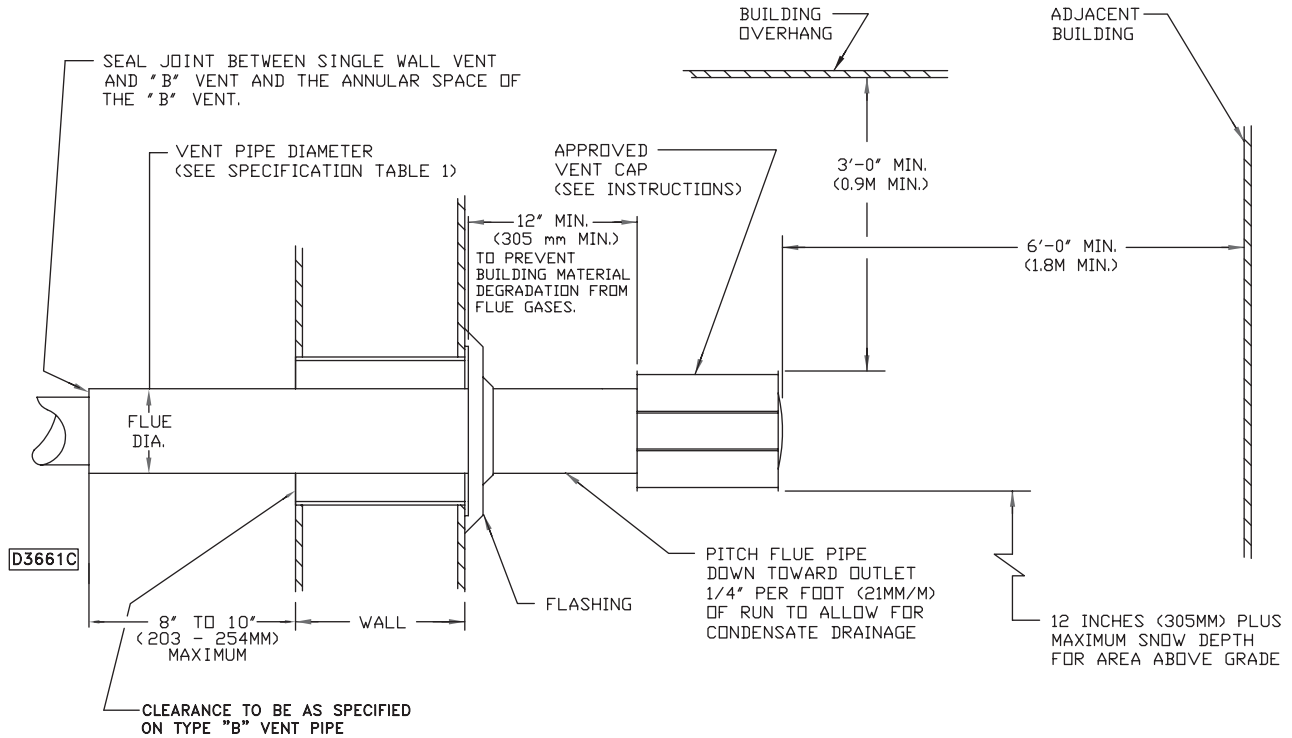
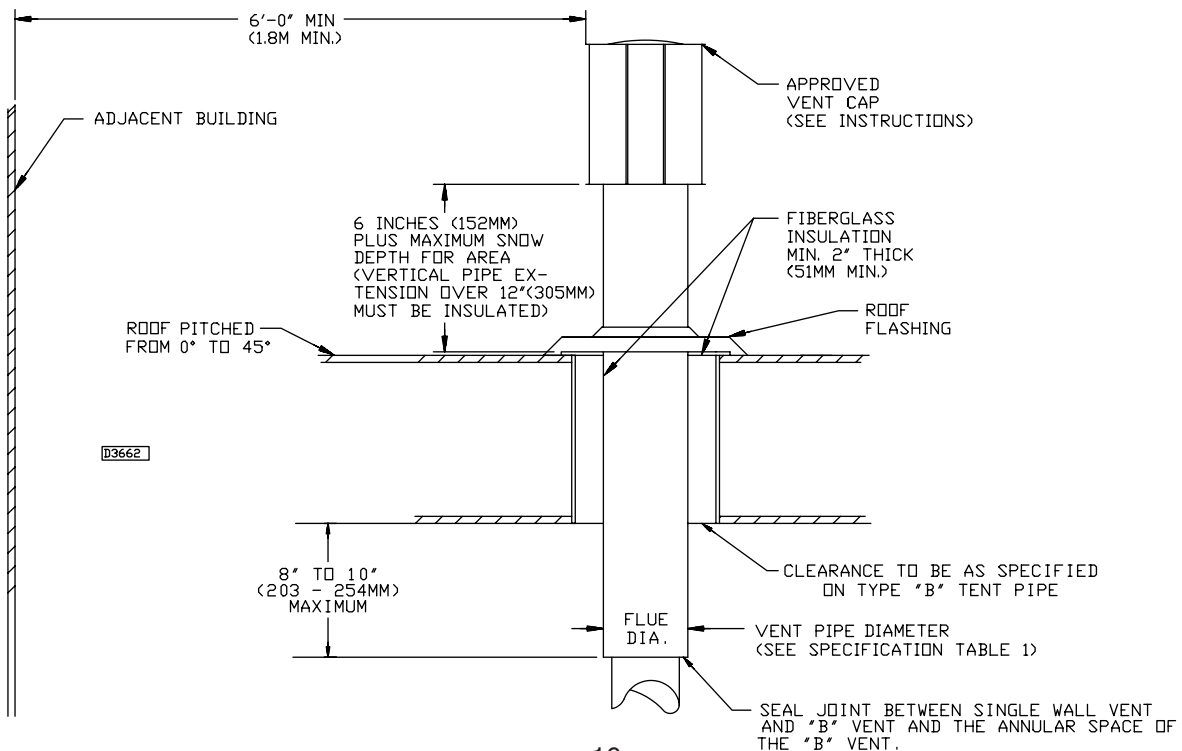

Figure 11B

VERTICAL ARRANGEMENT

SINGLE WALL VENT SYSTEM TO DOUBLE WALL TERMINATION



OPERATION

POWER VENTED PROPELLER UNITS

DIRECT SPARK IGNITION

EXPLANATION OF CONTROLS (see Figure 12):

1. The unit heater is equipped with a power vent system that consists of a power venter motor and blower, pressure switch, and sealed flue collector in place of the conventional draft diverter.
2. The power venter motor is energized by the room thermostat through the integrated control board when a demand for heat is sensed. The pressure switch measures the flow through the vent system and energizes the direct spark ignition system beginning the pre-purge timing when the flow is correct.

▲ WARNING The pressure switch **MUST NOT** be bypassed. The unit **MUST NOT** be fired unless the power venter is operating. An unsafe condition could result.

3. The direct ignition system consists of an ignition control module and a gas valve. When the pre-purge period ends, the spark ignition system is energized, and the gas valve opens to supply gas to the burners. When the thermostat is satisfied, the vent system is de-energized and the valve closes to stop the flow of gas to the unit.
4. The limit switch interrupts the flow of electric current to the control board, interrupting the flow of gas to the gas valve if the unit heater becomes overheated.
5. Once the thermostat is satisfied, or the limit switch interrupts the flow of electric current to the control board, the unit will begin a post-purge period. When the post-purge period ends, the power venter motor is de-energized.
6. The fan operation is delayed 30 seconds once the thermostat is closed, and continues operation for 30 seconds after the thermostat opens. **The start-up fan delay must not exceed 30 seconds from a cold start.**

7. The wall thermostat, supplied optionally, is a temperature sensitive switch that operates the vent system and ignition system to control the temperature of the space being heated. The thermostat must be mounted on a vertical, vibration-free surface free from air currents and in accordance with the furnished instructions (also refer to Electrical Section).

START-UP (Also refer to lighting instruction plate equipped on the unit)

1. Open the manual gas valve in the gas supply line to the unit heater with union connection loose, purge air from the gas line. Tighten the union and check for leaks.

▲ WARNING Never use an open flame to detect gas leaks. Explosive conditions may exist which could result in personal injury or death.

2. Open the manual valve on the unit heater.
3. Turn ON the electrical power.
4. The unit should be under the control of the thermostat. Turn the thermostat to the highest point and determine that the power venter motor starts and the burners ignite. Turn the thermostat to the lowest point and determine that the power venter motor shuts off and the burners are extinguished.
5. Turn the thermostat to the desired position.
6. See Gas Input Rate and Adjustments sections.

SHUT DOWN

1. Turn the valve selector lever to the "OFF" position.
2. Turn off the electricity.
3. To relight, follow "start-up" instructions.

See Figure 12 for parts/identification.

Figure 12

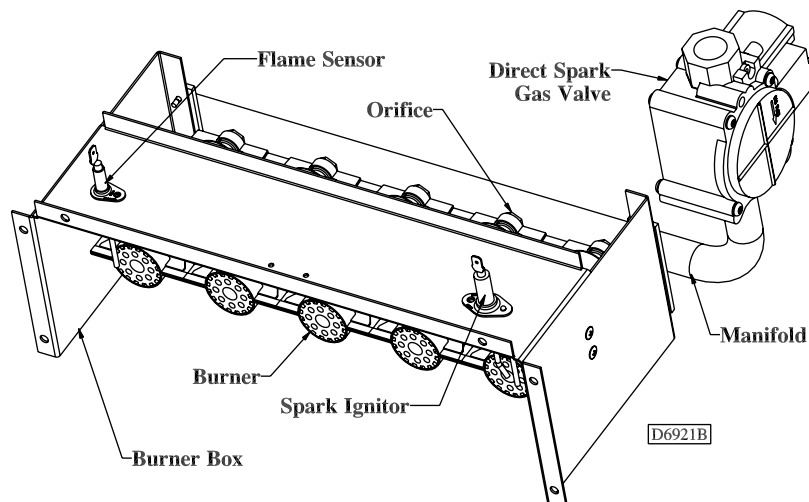

PRIMARY AIR SHUTTER ADJUSTMENT

Primary air adjustment is made at the factory. No field adjustments are necessary.

GAS INPUT RATE

Check the gas input rate as follows (Refer to General Safety Information section for metric conversions).

▲ CAUTION Never overfire the unit heater, as this may cause unsatisfactory operation, or shorten the life of the heater.

1. Turn off all gas appliances that use gas through the same meter as the unit heater.
2. Turn the gas on to the unit heater.
3. Clock the time in seconds required to burn 1 cubic foot of gas by checking the gas meter.
4. Insert the time required to burn one cubic foot of gas into the following formula and compute the input rate.

$$\frac{3600 \text{ (Sec. per Hr.)} \times \text{BTU/Cu. Ft.}}{\text{Time (Sec.)}} = \text{Input Rate}$$

For example:

Assume the BTU content of one cubic foot of gas is 1000, and that it takes 48 seconds to burn one cubic foot of gas.

$$\frac{3600 \times 1000}{48} = 75,000$$

NOTICE: If the computation exceeds, or is less than 95% of the gas BTU/hr. input rating (see Table 2), adjust the gas pressure.

Adjust the gas pressure as follows:

1. NATURAL GAS: Best results are obtained when the unit heater is operating at its full rated input with the manifold pressure of 3.5 inches W.C. (0.9 kPa). Adjustment of the pressure regulator is not normally necessary since it is preset at the factory. However, field adjustment may be made as follows:
 - a. Attach manometer at the pressure tap plug below the control outlet.
 - b. Remove the regulator adjustment screw cap, located on the combination gas valve.
 - c. With a small screwdriver, rotate the adjustment screw counterclockwise to decrease pressure, or clockwise to increase pressure.
 - d. Replace regulator adjustment screw cap.

2. PROPANE GAS: An exact manifold pressure of 10.0 inches W.C. (2.5 kPa) must be maintained for proper operation of the unit heater. If the unit is equipped with a pressure regulator on the combination gas valve, follow steps "a" through "d" above. If the unit is not so equipped, the propane gas supply system pressure must be regulated to attain this manifold operating pressure.
3. The adjusted manifold pressure should not vary more than 10% from pressure specified in Table 3.

Table 3 - Main Burner Orifice Schedule*

* INPUT IN 1000 BTU	TYPE OF GAS	NATURAL	PROPANE	NO. OF BURNER ORIFICES
	HEATING VALUE	1075 BTU/Ft ³ (40.1 MJ/m ³)	2500 BTU/Ft ³ (93.1 MJ/m ³)	
	MANIFOLD PRESSURE	3.5" W.C. (0.87kPa)	10" W.C. (2.49 kPa)	
30	FT ³ /HR ORIFICE DRILL	28 49	12 57	2
45	FT ³ /HR ORIFICE DRILL	42 49	18 57	3
60	FT ³ /HR ORIFICE DRILL	56 49	24 57	4
75	FT ³ /HR ORIFICE DRILL	70 49	30 57	5
90	FT ³ /HR ORIFICE DRILL	70 49	30 57	5

*This schedule is for units operating at normal altitudes of 2000 ft. (610m) or less.

When installed in Canada, any references to deration at altitudes in excess of 2000 ft. (610m) are to be ignored. At altitudes of 2000 to 4500 ft. (610 to 1372m), the unit heaters must be orificed to 90% of the normal altitude rating, and be so marked in accordance with ETL certification.

TUBULAR UNIT HEATER HIGH ALTITUDE DERATION

This Tubular Unit Heater has been manufactured utilizing standard burner orifices and a normal manifold pressure setting as per the specifications shown on your unit rating plate.

All unit deration must be done through field adjustments by a qualified technician. Once the proper adjustments are made in the field, attach label #J17-06459 to the unit, and record adjusted manifold pressure, altitude of the unit installation and the technician's name and date on the label using a permanent marker.

Refer to Installation Instruction section on Adjustments-Gas Input Rate for adjusting the manifold pressure.

Table 4

Altitude (Feet)	NATURAL GAS		PROPANE (LP) GAS	
	*Heating Value BTU/Cu. ft.	Manifold Pressure (In. W.C.)	*Heating Value BTU/Cu. ft.	Manifold Pressure (In. W.C.)
2,000	948	3.5	2,278	8.6
2,500	931	3.5	2,237	8.5
3,000	914	3.3	2,196	8.4
3,500	897	3.2	2,156	8.4
4,000	881	3.2	2,116	8.3
4,500	865	3.2	2,077	8.2
5,000	849	3.1	2,039	8.1
5,500	833	3.1	2,000	8.0
6,000	818	3.0	1,964	7.9
6,500	802	3.0	1,927	7.7
7,000	787	2.9	1,891	7.6
7,500	771	2.9	1,853	7.5
8,000	756	2.8	1,817	7.4
8,500	741	2.8	1,781	7.2
9,000	726	2.7	1,745	7.1
9,500	711	2.7	1,709	6.9
10,000	696	2.6	1,673	6.8

*Notes:
 1. Consult local utility for actual heating value.
 2. Tables based on heating value of 1,050 BTU/Cu. ft. at sea level.

MAINTENANCE

PERIODIC SERVICE

NOTICE: The heater and vent system should be checked once a year by a qualified technician.

All Maintenance/Service information should be recorded accordingly on the Inspection Sheet provided in this manual.

▲ WARNING Open all disconnect switches and disconnect all electrical and gas supplies and secure in that position before servicing unit. Failure to do so may result in personal injury or death from electrical shock.

▲ WARNING Gas tightness of the safety shut-off valves must be checked on at least an annual basis.

To check gas tightness of the safety shut-off valves, turn off the manual valve upstream of the appliance combination control. Remove the 1/8 inch pipe plug on the inlet side of the combination control and connect a manometer to that tapping. Turn the manual valve on to apply pressure to the combination control. Note the pressure reading on the manometer, then turn the valve off. A loss of pressure indicates a leak. If a leak is detected, use a soap solution to check all threaded connections. If no leak is found, combination control is faulty and must be replaced before putting appliance back in service.

Should maintenance be required, perform the following inspection and service routine:

1. Inspect the area near the unit to be sure that there is no combustible material located within the minimum clearance requirements listed in this manual.

▲ WARNING Under no circumstances should combustible material be located within the clearances specified in this manual. Failure to provide proper clearance could result in personal injury or equipment damage from fire.

2. Turn off the manual gas valve and electrical power to the unit heater.
3. Remove service panel.
4. To clean or replace the burners, remove the four screws holding the manifold to the burner box and pull the manifold back slightly to disengage the orifices from the burners. Remove each burner by holding it against the tab on the burner bracket, then rotate the inlet end of the burner toward the fan side of the unit and slide the burner off the tabs. See Figure 10.
5. With the burners removed, wire brush the inside surfaces of the heat exchanger.
6. Remove any dirt, dust, or other foreign matter from the burners using a wire brush and/or compressed air. Ensure that all parts are unobstructed.
7. Reassemble the unit heater by replacing all parts in reverse order.
8. Check the burner adjustment.
9. Check all gas control valves and pipe connections for leaks.
10. Check the operation of the automatic gas valve by lowering the setting of the thermostat, stopping the operation of the gas duct furnace. The gas valve should close tightly, completely extinguishing the flame on the burners.
11. Inspect and service motor/fan assembly. To maintain efficient air flow, inspect and clean the fan blades and guard to prevent buildup of foreign matter.
12. Check lubrication instructions on motor. If oiling is required, add 3 or 4 drops of electric motor oil as follows:
 - a. Light Duty - After 3 years or 25,000 hours of operation.
 - b. Average Duty - Annually after 3 years or 8,000 hours of operation.
 - c. Heavy Duty - Annually after 1 year or at least 1500 hours of operation.

▲ CAUTION Never over oil the motor or premature failure may occur!

13. Check and test the operational functions of all safety devices supplied with your unit.

Table 5 - Tubular Propeller Troubleshooting Guide

SYMPTOMS	POSSIBLE CAUSE(S)	CORRECTIVE ACTION
A. Flame pops back.	1. Burner orifice too small.	1. Check with local gas supplier for proper orifice size and replace. Refer to "Operation".
B. Noisy Flame.	1. Irregular orifice causing whistle or resonance. 2. Excessive gas input.	1. Replace orifice. 2. Test and reset manifold pressure.
C. Yellow tip flame (some yellow tipping on LP gas is permissible).	1. Clogged main burners. 2. Misaligned orifices. 3. Insufficient combustion air. 4. Possibly over fired.	1. Clean main burner ports. 2. Replace manifold assembly. 3. Insufficient combustion air. 4. Check gas input and manifold pressures.
D. Floating flame.	1. Blocked venting. 2. Insufficient combustion air. 3. Blocked heat exchanger. 4. Air leak into combustion chamber or draft hood.	1. Clean Flue. Refer to "Installation". 2. Clean combustion air inlet openings. 3. Clean heat exchanger. Refer to "Installation". 4. Determine cause and repair accordingly.
E. Gas odor.	1. Shut off gas supply immediately! 2. Leaking gas test port on valve. 3. Blocked heat exchanger. 4. Blocked draft hood. 5. Negative pressure in the building.	1. Inspect all gas piping and repair. 2. Check to ensure gas test ports are seated. 3. Clean heat exchanger/flue. 4. Clean flue collector. 5. See "Installation".
F. Delayed ignition.	1. Improper ground. 2. Bad or broken spark cable. 3. Faulty control. 4. Pressure regulator set too low. 5. Main burner orifices dirty. 6. Improper venting.	1. Check grounding wires and spark bracket connections. 2. Inspect spark cable connections and cuts. 3. Check to ensure spark is energized after pre purge period. 4. Test and reset manifold pressure refer to "Operations". 5. Clean or replace orifices. 6. Refer to "Installation".
G. Failure to ignite.	1. Gas supply is off. 2. No power supply to unit. 3. Thermostat not calling. 4. Defective high limit. 5. Defective drafter prove switch. 6. Loose wiring. 7. Improper ground. 8. Improper thermostat or transformer wiring.	1. Open all manual valves " check for leaks ". 2. Turn on power supply, check fuses and replace if bad. 3. Turn up thermostat, Check for 24v on terminals R and W1 on terminal strip. 4. Check switch for continuity if open with no heat present, replace. 5. Check switch operation to ensure switch closes after drafter purge period. If it does not make check tubing connections/ blockage. 6. Check all wiring per diagram. 7. Check all ground wires and connections. 8. Check both, for wiring according to diagram; check for 24V at gas valve terminals during trial for ignition period if present and valve does not open. Replace valve.
H. Condensation.	1. Improper venting. 2. Unit under fired. 3. Building too cold.	1. Refer to "Installation, Venting". 2. Check gas supply pressures to unit. Refer to "Installation". 3. Refer to "Installation".

Table 5 - Tubular Propeller Troubleshooting Guide (continued)

SYMPTOMS	POSSIBLE CAUSE(S)	CORRECTIVE ACTION
I. Burners will not shut off.	<ol style="list-style-type: none"> 1. Thermostat located incorrectly. 2. Improper thermostat wiring. 3. Shorted circuit. 4. Defective sticking gas valve. 5. Excessive gas supply pressure. 	<ol style="list-style-type: none"> 1. Relocate thermostat away from outside wall or drafts. 2. Check thermostat circuit for open and close on terminal strip on heater "R" and "W". 3. Check thermostat circuit for shorts "staples piercing wires". 4. Check for 24v on gas valve terminals when thermostat is not calling. 5. Refer to "Installation".
J. Rapid burner cycling.	<ol style="list-style-type: none"> 1. Loose electrical connections at thermostat or gas valve. 2. Excessive thermostat heat anticipator setting. 3. Unit cycling on high limit. 4. Poor thermostat location. 	<ol style="list-style-type: none"> 1. Tighten all electrical connections. 2. Adjust heat anticipator setting for longer cycles. Refer to "Electrical Connection". 3. Check for proper air supply across heat exchanger and proper gas supply. 4. Relocate thermostat .
K. Noisy power ventor.	<ol style="list-style-type: none"> 1. Power ventor wheel loose. 2. Power ventor wheel is dirty. 3. Power ventor wheel is rubbing on the housing. 	<ol style="list-style-type: none"> 1. Replace or tighten. 2. Clean power ventor wheel. 3. Realign power ventor wheel.
L. Fan will not run.	<ol style="list-style-type: none"> 1. Loose electrical connections. 2. Defective motor or overload. 3. Defective control board. 	<ol style="list-style-type: none"> 1. Check and tighten wires on fan circuit. 2. Test for 115v on terminal ACB Heat and "L2" if voltage is present replace motor. 3. Test for 115v on terminal ACB Heat and "L2" on the control board, if voltage is not present 45 seconds after trial for ignition replace board.
M. Fan motor turns on and off while burner is operating.	<ol style="list-style-type: none"> 1. Motor overload protection is tripping. 2. Loose wiring or connection. 3. Control board is defective. 	<ol style="list-style-type: none"> 1. Check motor amps against motor name plate, check voltage, replace if found defective. 2. Check for 115v between motor leads. 3. Check terminal ACB Heat for voltage if voltage not constant, replace board.
N. Fan will not stop.	<ol style="list-style-type: none"> 1. Control Board is in flame failure mode. 2. Fan improperly wired. 3. Defective board. 	<ol style="list-style-type: none"> 1. Turn 115v power off to the unit, wait 10 seconds and reapply voltage to the unit. 2. Check wiring of fan circuit to wiring diagram. 3. If unit is not calling for heat and board is not in a flash code mode, replace board.
O. Not enough heat.	<ol style="list-style-type: none"> 1. Incorrect gas input. 2. Heater undersized. 3. Thermostat malfunction. 4. Heater cycling on limit. 5. Incorrect orifice sizes. 	<ol style="list-style-type: none"> 1. Refer to "Operation". 2. Is the heater output sized correctly for heat loss of the space. Has the space been enlarged. 3. Check thermostat circuit, 24v on terminals "R" and "W" on terminal strip. 4. Check air movement across heat exchanger. Check voltage and amps at the fan motor. Check gas input to ensure unit is not over fired. Check heat exchanger to ensure unit is not dirty. 5. Check orifice size, replace if undersized.
P. Too much heat.	<ol style="list-style-type: none"> 1. Unit is over fired. 2. Thermostat malfunction. 3. Heater runs continuously. 	<ol style="list-style-type: none"> 1. Refer to "Operation". Check orifice size. If too big replace. 2. Check thermostat for operation, to ensure circuit open and closes. 3. Check wiring per diagram; check operation at the gas valve, look for a short in thermostat circuit.

Table 5 - Tubular Propeller Troubleshooting Guide

SYMPTOMS	POSSIBLE CAUSE(S)	CORRECTIVE ACTION
Q. Cold air is delivered during heater operation.	<ol style="list-style-type: none"> 1. Incorrect manifold pressure or input. 2. Air throughput too high. 	<ol style="list-style-type: none"> 1. Refer to "Operation". 2. Refer to "Operation".
R. High limit tripping.	<ol style="list-style-type: none"> 1. Unit is over fired. 2. Air flow is low. 3. Defective switch. 4. Defective control board. 	<ol style="list-style-type: none"> 1. Burner orifices may be too large, verify and replace. 2. Check for proper voltage, ensure fan blade is correct. 3. Check operation of switch, did the switch open when unit is running or is the switch open during start-up. 4. Check for 24v on line side of the high limit. Constant voltage should be recorded if not control board is suspect. Check flash code.
S. Power ventor will not run.	<ol style="list-style-type: none"> 1. Loose wiring or connections. 2. Motor overload is tripped or bad motor. 3. Bad control board. 	<ol style="list-style-type: none"> 1. Check all wiring in the power vent circuit to ensure good connection, including "Neutral". 2. Check for 115v between motor leads and check amp draw of motor. Replace if needed. 3. Check for continuous 115v on terminal "CBM Blower" and neutral during call for heat. If not present and all checks are normal, replace.
T. Power ventor turns on and off during operation.	<ol style="list-style-type: none"> 1. Power ventor improperly wired. 2. Motor overload cycling or defective motor. 3. Defective control board. 	<ol style="list-style-type: none"> 1. Check power ventor circuit per wiring diagram. 2. Check motor voltage and amp draw to motor name plate, replace if motor found defective. 3. Check for continuous 115v on terminal "CMB Blower" during call for heat, replace board if found defective.
U. Power ventor will not stop.	<ol style="list-style-type: none"> 1. Power ventor improperly wired. 2. Main burner did not light on call for heat. 3. Defective control board. 	<ol style="list-style-type: none"> 1. Check power ventor circuit per wiring diagram. 2. Heater is in lockout mode check flash code table for problem. 3. No flash codes present along with no call for heat, replace control board.

Table 6 - Troubleshooting with LED Indicator Assistance

No Cycling or appliance power or thermostat call for heat since appliance failure has occurred.

▲ WARNING

Line voltage power can cause product damage, severe injury or death. Only a trained experienced service technician should perform this troubleshooting.

1. Check the system thermostat to make sure it is calling for heat. (Do not cycle the thermostat on and off at this time.)
2. Remove the appliance burner compartment door. Do not interrupt power to control board by opening any electrically interlocked panels.
3. Observe the LED indicator on the control board (a green LED labeled "OK" indicates system faults); check and repair system as noted in the chart to the right.

***NOTICE: Air flow proving switch and power ventor hose barbs must be free of any dust or debris at all times. Periodically check these openings and/or if any problems occur.**

LED STATUS	INDICATES	CHECK/REPAIR
Slow Flash	Control OK, no call for heat.	Not Applicable
Fast Flash	Control OK, call for heat present.	Not Applicable
Steady Off	Internal control fault, or no power.	1. Line voltage on terminals 120 and C on transformer. 2. Low voltage (24V) on terminals 24 and C on transformer. 3. 5 Amp fuse on circuit board.
Steady On	Control internal failure or bad ground.	1. Common side of transformer grounded to chassis. 2. Loose spark ignitor.
2 Flashes	In lockout from failed ignitions or flame losses.	1. Gas supply off or gas supply pressure too low. 2. Flame sense rod contaminated or loose wire. 3. Gas valve switch is off or wires are not connected. 4. Broken or cracked porcelain on flame probe or spark ignitor.
3 Flashes	Pressure Switch open with inducer on or closed with inducer off.	1. Obstructions or restrictions in appliance air intake or flue outlet are preventing proper combustion airflow. 2. Moisture or debris in tubing that connects pressure switch and draft inducer. 3. Airflow switch jumpered or miswired.
4 Flashes	Limit or rollout switch is open.	1. Open manual reset rollout switch. 2. Gas pressure too high, over fire condition. 3. Incorrect airflow due to blockage or motor not operating.
5 Flashes	Flame sensed while gas valve is off.	1. Flame probe miswired or shortened.
6 Flashes	On-board microprocessors disagree.	1. Thermostat is interfering with control board.

IDENTIFICATION OF PARTS TUBULAR 30-90 MBH UNIT SIZES

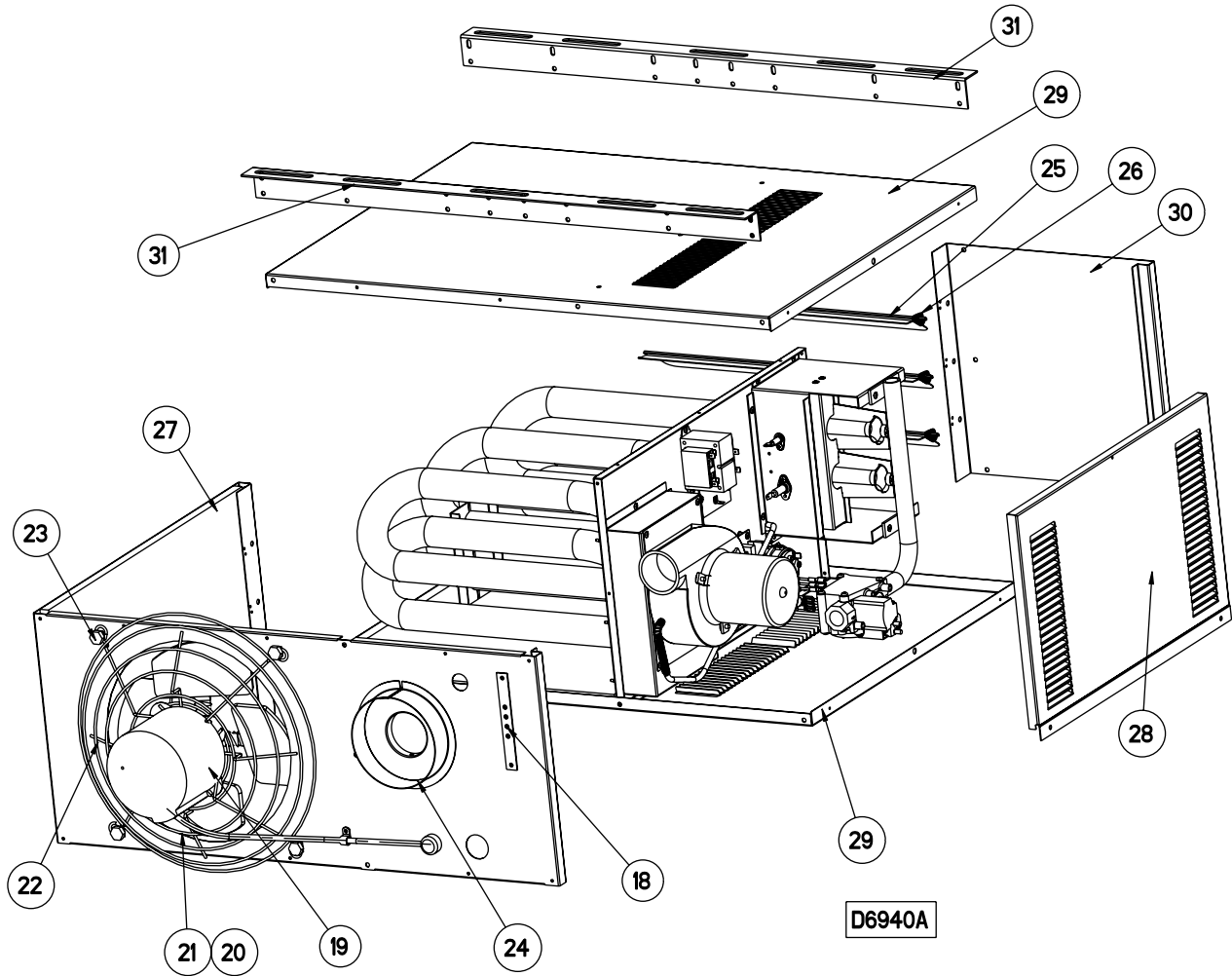

Item No.	Item Description
18	Terminal Block Plate
19	Fan Motor
21	Standard Fan Guard
20	OSHA Fan Guard (not shown)
22	Standard Fan
23	Fan/Guard/Motor Mount Hardware Kit
24	Flue Collar Assembly
25	Louver

Item No.	Item Description
26	Louver Spring
27	Side/Rear Jacket Panel with Insulation
28	Service Panel
29	Top Jacket Panel with Insulation
29	Bottom Jacket Panel with Insulation
30	Front Jacket
31	Front Hanger
31	Rear Hanger

IDENTIFICATION OF PARTS TUBULAR 30-90 MBH UNIT SIZES

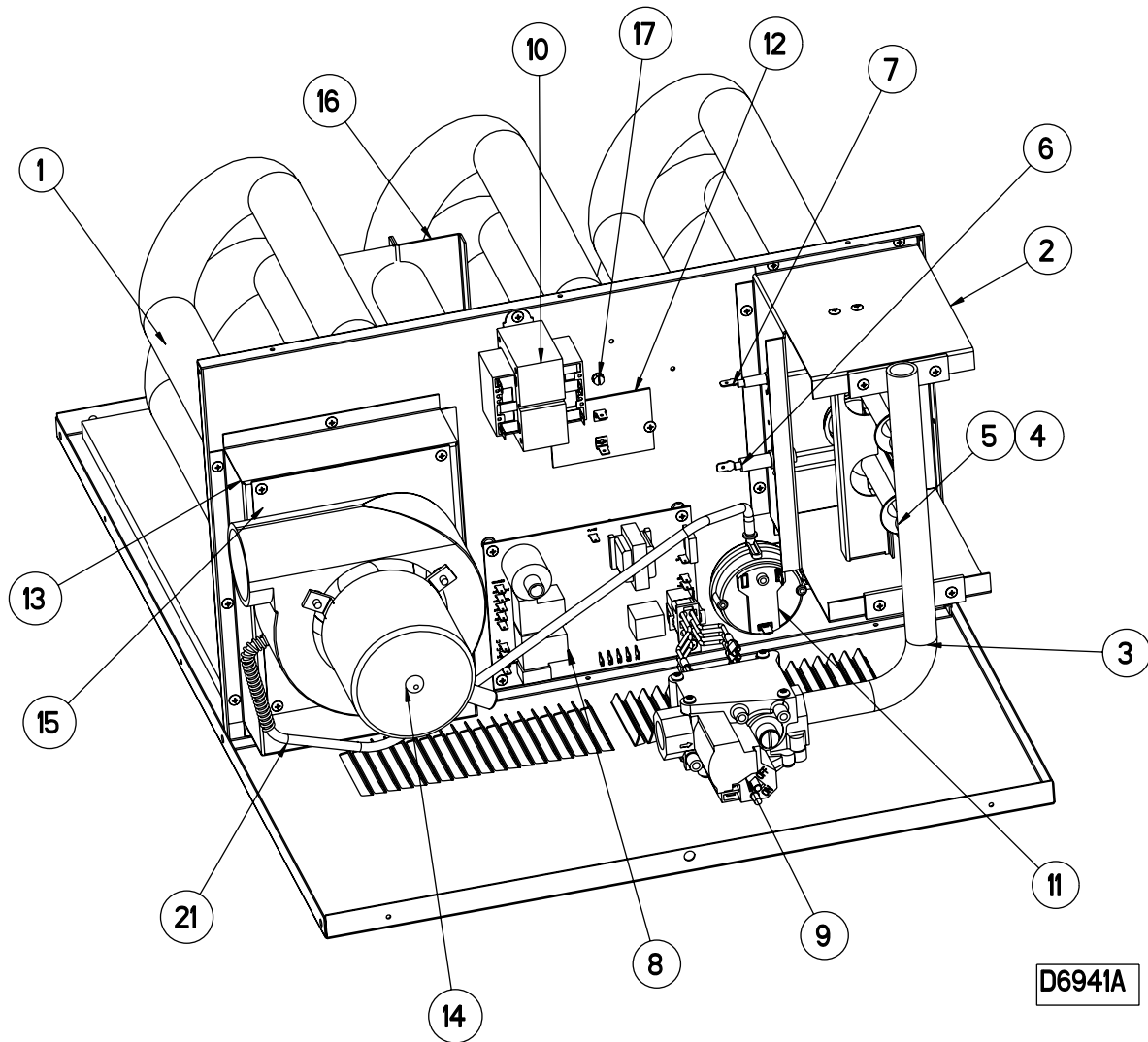

Item No.	Item Description
1	Vestible Panel/Tube Assembly (Heat Exchanger)
2	Manifold Bracket Sub-Assembly
3	Manifold
4	Inshot Burner
5	*Standard Orifice Natural Gas or Propane (LP) Gas
6	Ignitor
7	Flame Sensor
8	Control Board
9	Gas Valve, Single Stage Natural or Propane (LP) Gas

Item No.	Item Description
10	Transformer, 50 VA, 115/24
11	Air Pressure Switch
12	High Limit Switch with Mounting Bracket
13	**Flue Collector
14	Power Venter (Drafter) Assembly
15	Power Venter Mounting Plate
16	Tube Support Bracket Kit
17	Green Ground Screw
21	Vinyl Tubing (Pressure Switch)

* The orifices shown are for units operating at normal altitudes of 0 to 2000 ft. (610m). Special orifices are required for unit installations above 2000 ft. (610m).

** When replacing a flue collector, make sure that the flue collector box is sealed completely to the vestibule panel using RTV Sealant.

IDENTIFICATION OF PARTS TUBULAR 30-90 MBH UNIT SIZES

Figure 13 - Propeller Parts

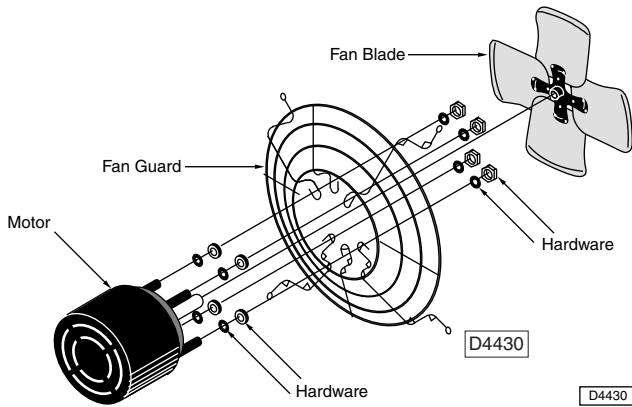

NOTE: No rubber grommets are equipped with the 30 and 45 unit sizes.

Figure 14 - Component Parts

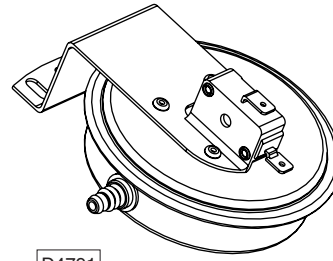

Pressure Switch

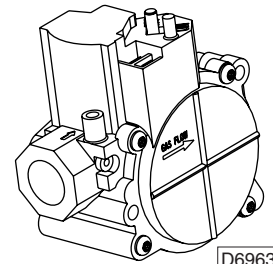

Gas Valve

Figure 15 - Internal Furnace Components

Unit Size	Tube Quant.
30 MBH	2
45 MBH	3
60 MBH	4
75 MBH	5
90 MBH	5

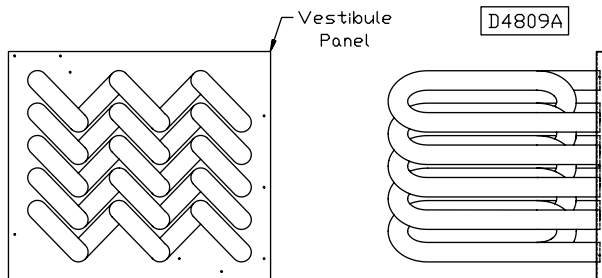
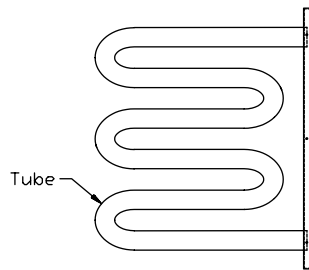

Heat Exchanger Assembly

Figure 16 - Power Ventrator Assembly

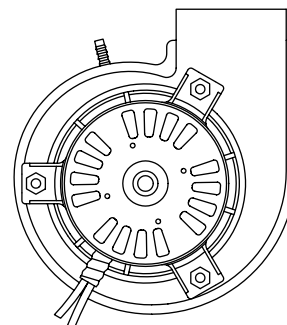
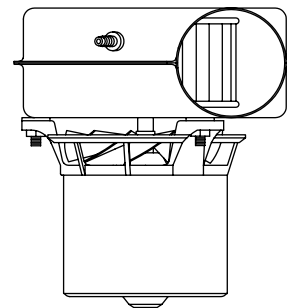

D4810

HOW TO ORDER REPLACEMENT PARTS

Please send the following information to your local representative: if further assistance is needed, contact the manufacturer's customer service department.

- Model Number
- Serial Number (if any)
- Part Description and Number as shown in Replacement parts Catalog

LIMITED WARRANTY Power Vented Tubular Propeller Unit Heaters

1. The "Manufacturer" warrants to the original owner at original installation site that the above model Gas-Fired Heater ("the Product") will be free from defects in material or workmanship for (1) year from the date of shipment from the factory, or one and one-half (1-1/2) years from the date of manufacture, whichever occurs first. The Manufacturer further warrants that the complete heat exchanger, flue collector and burners be free from defects in material or workmanship for a period of ten (10) years from the date of manufacture. If upon examination by the Manufacturer the Product is shown to have a defect in material or workmanship during the warranty period, the manufacturer will repair or replace, at its option, that part of the Product which is shown to be defective.
2. This limited warranty does not apply:
 - a. if the product has been subjected to misuse or neglect, has been accidentally or intentionally damaged, has not been installed, maintained, or operated in accordance with furnished written instructions, or has been altered or modified in any way by any unauthorized person.
 - b. to any expenses, including labor or material, incurred during removal or reinstallation of the Product
 - c. to any damage due to corrosion by chemicals, including halogenated hydrocarbons, precipitated in the air
 - d. to any workmanship of the installer of the Product
3. This limited warranty is conditional upon:
 - a. advising the installing contractor, who in turn notify the distributor or manufacturer
 - b. shipment to the Manufacturer of that part of the Product thought to be defective. Goods can only be returned with prior written approval of the Manufacturer. All returns must be freight prepaid.
 - c. determination in the reasonable opinion of the Manufacturer that there exists a defect in material or workmanship
4. Repair or replacement of any part under this Limited Warranty shall not extend the duration of the warranty with respect to such repaired or replaced part beyond the stated warranty period.
5. **THIS LIMITED WARRANTY IS IN LIEU OF ALL WARRANTIES, EITHER EXPRESS OR IMPLIED, AND ALL SUCH OTHER WARRANTIES, INCLUDING WITHOUT LIMITATION IMPLIED WARRANTIES OF MERCHANTABILITY OR FITNESS FOR A PARTICULAR PURPOSE, ARE HEREBY DISCLAIMED AND EXCLUDED FROM THIS LIMITED WARRANTY. IN NO EVENT SHALL THE MANUFACTURER BE LIABLE IN ANY WAY FOR ANY CONSEQUENTIAL, SPECIAL, OR INCIDENTAL DAMAGES OF ANY NATURE WHATSOEVER, OR FOR ANY AMOUNTS IN EXCESS OF THE SELLING PRICE OF THE PRODUCT OR ANY PARTS THEREOF FOUND TO BE DEFECTIVE. THIS LIMITED WARRANTY GIVES THE ORIGINAL OWNER OF THE PRODUCT SPECIFIC LEGAL RIGHTS. YOU MAY ALSO HAVE OTHER RIGHTS WHICH MAY VARY BY JURISDICTION.**

In the interest of product improvement, we reserve the right to make changes without notice.

GAS EQUIPMENT START-UP

Customer _____ Job Name & Number _____

PRE-INSPECTION INFORMATION With power and gas off.

Type of Equip: Unit Heater

Serial Number _____ Model Number _____

Name Plate Voltage: _____ Name Plate Amperage: _____

Type of Gas: Natural LP Tank Capacity _____ lbs. Rating: _____ BTU @ _____ °F
_____ kg _____ kw @ _____ °C

- Are all panels, doors, vent caps in place?
- Has the unit suffered any external damage? Damage _____
- Does the gas piping and electric wiring appear to be installed in a professional manner?
- Has the gas and electric been inspected by the local authority having jurisdiction?
- Is the gas supply properly sized for the equipment?
- Were the installation instructions followed when the equipment was installed?
- Have all field installed controls been installed?
- Do you understand all the controls on this equipment? ***If not, contact your wholesaler or rep.***
(DO NOT START this equipment unless you fully understand the controls.)

GENERAL

With power and gas off.

- Make certain all packing has been removed.
- Tighten all electrical terminals and connections.
- Check all fans & blowers for free movement.
- Check all controls for proper settings.

GAS HEATING

With power and gas on.

- Inlet gas pressure. _____ in. W.C. or _____ kPa
- Burner ignition.
- Manifold gas pressure. _____ in. W.C. or _____ kPa
- Cycle on HIGH LIMIT.
- Cycle and check all other controls not listed.
- Check operation of remote panel.

Remarks: _____
