

BEACON/MORRIS “BSC” SERIES SEPARATED COMBUSTION TUBULAR BLOWER STYLE UNIT HEATER



ENERGY PERFORMANCE VERIFIED
RENDIMENT ENERGETIQUE VERIFIE



BSCS-2

Intertek

SEPARATED COMBUSTION

The Beacon/Morris “BSC” Series Separated Combustion Tubular Blower Gas-Fired Unit Heater offers a highly efficient, extremely durable alternative to the traditional clam shell design. Additionally, the “BSC” unit heater “separates” the combustion process from the environment where the unit is installed. A power venting system draws a controlled quantity of combustion air from outside the building. The same system exhausts flue products to the outside. The burners, pilot and flue system are enclosed within the unit; thus, the entire combustion process is unaffected by the atmosphere in the space where the heater is located. Separated combustion units are designed to be installed where dusty, dirty or mildly corrosive conditions exist or where high humidity or slightly negative pressures prevail.

Units are available in sizes 100 to 400 MBH. The “BSC” is certified by ETL as providing 83% thermal (combustion) efficiency.



TUBULAR HEAT EXCHANGER

The Beacon/Morris tubular heat exchanger has been designed to provide maximum and uniform heat transfer. The low pressure drop associated with this design enables heated air to be evenly distributed to the conditioned space. This curved, non-welded serpentine design experiences less thermally induced stress making it highly durable for significantly longer service life. All Beacon/Morris tubular heat exchangers are constructed of heavy duty 20-gauge aluminized steel. Optional 409 stainless steel heat exchangers are also available.

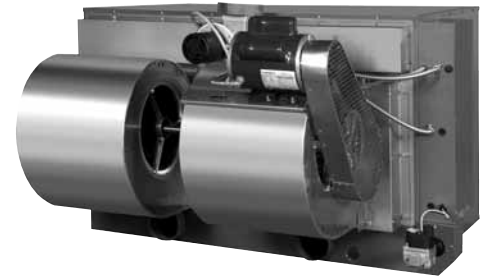

DIRECT SPARK IGNITION SYSTEM

Beacon/Morris “BSC” units utilize a direct spark pilotless ignition of the burner, providing fast heat delivery. This highly reliable and efficient ignition system incorporates an integrated electronic control board to regulate the system sequence of operation, including an onboard LED indicator for simple troubleshooting.

VENTING

The Beacon/Morris “BSC” unit heater is ETL certified in accordance with categories I and III venting requirements. This certification allows units to be vented both vertically and horizontally using either single wall or double wall venting materials. Available as an accessory option, Beacon/Morris offers a Combustion Air Inlet Kit that allows for concentric venting of both combustion and exhaust air systems through one termination.

CAUTIONS

Combustion air and vent systems must be installed in accordance with current National Fuel Gas Code or Installation Code, Installation Code for Natural Gas Burning Appliances and Equipment (Canada) and any local and state codes. Units should not be installed where negative pressures are significant, where vapor containing chlorine or fluorine may be present or in any areas classified as “hazardous.”

STANDARD FEATURES

- Enclosed combustion system
- 20-gauge aluminized steel tubular heat exchanger
- 83% thermal efficiency
- ODP blower motor (with overload protection)
- Power venter
- Combustion air pressure switch
- 20-gauge steel cabinetry with baked enamel finish
- Direct spark ignition system
- 115/24 volt control transformer
- 115/1/60 supply voltage
- Redundant single stage gas valve
- Rear burner access
- Individually adjustable and removable horizontal louvers
- Complete belt guard
- Main control panel
- 10 year heat exchanger, flue collector and burner warranty

OPTIONAL FEATURES

- Stainless steel heat exchanger, burners, and/or flue collector
- Supply voltages: 208 & 230/1/60 and 208, 230, 460, 575/3/60
- Two stage and various electronic modulation gas controls
- Premium efficiency blower motors in ODP & TE types
- Discharge nozzles (30°, 60° & 90°) or duct flange assembly
- Combustion air inlet kits (allows concentric venting with horizontal or vertical termination)



01/14

260 North Elm Street • Westfield, MA 01085
Tel: (413) 562-5423 Fax: (413) 572-3764
www.beacon-morris.com



PROJECT: _____

UNIT TAG: _____

"BSC" SEPARATED COMBUSTION TUBULAR BLOWER PERFORMANCE AND DIMENSIONAL DATA



ENERGY
PERFORMANCE
VERIFIED
RENDIMENT
ENERGETIQUE
VERIFIE



Intertek

Unit Capacity (MBH)	100	125	150	175	200	250	300	350	400
PERFORMANCE DATA†									
Input - BTU/Hr.	100,000	125,000	150,000	175,000	200,000	250,000	300,000	350,000	400,000
(kW)	(29.3)	(36.6)	(44.0)	(51.3)	(58.6)	(73.3)	(87.9)	(102.6)	(117.2)
Output - BTU/Hr.	83,000	103,750	124,500	145,250	166,000	207,500	246,000	290,500	332,000
(kW)	(24.3)	(30.4)	(36.5)	(42.6)	(48.6)	(60.8)	(72.1)	(85.1)	(97.3)
Thermal Efficiency - %	83	83	83	83	83	83	82	83	83
Free Air Delivery - CFM	1,181	1,476	1,771	2,067	2,362	2,953	3,501	4,134	4,724
(cu. m/s)	(0.557)	(0.697)	(0.836)	(0.976)	(1.115)	(1.394)	(1.652)	(1.951)	(2.230)
Air Temperature Rise - °F	65	65	65	65	65	65	65	65	65
(°C)	(36)	(36)	(36)	(36)	(36)	(36)	(36)	(36)	(36)
Outlet Velocity - FPM	370	463	555	395.0	451.0	564.0	422	498	570
(m/s)	(1.879)	(2.351)	(2.819)	(2.006)	(2.291)	(2.864)	(2.143)	(2.529)	(2.895)
Full Load Amps at 115V	7.3	9.4	9.4	14.2	14.2	15.6	15.6	20.8	20.8
Maximum Circuit Ampacity	8.6	11.2	11.2	17.1	17.1	18.9	18.9	25.4	25.4
MOTOR DATA: Motor HP	1/4	1/2	1/2	3/4	3/4	1	1	1-1/2	1-1/2
Motor kW	0.19	0.37	0.37	0.56	0.56	0.75	0.75	1.11	1.11
Motor Type ODP**	SPH	SPH	SPH	SPH	SPH	Cap. Start	Cap. Start	Cap. Start	Cap. Start
RPM	1,725	1,725	1,725	1,725	1,725	1,725	1,725	1,725	1,725
Amps @ 115V	5.1	7.2	7.2	11.6	11.6	13.0	13.0	18.2	18.2
DIMENSIONAL DATA - inches (mm)									
"A" Height to Top of Flue	33-3/4 (857)	33-3/4 (857)	33-3/4 (857)	33-3/4 (857)	33-3/4 (857)	33-3/4 (857)	34 (864)	34 (864)	34 (864)
"B" Jacket Width of Unit	20-3/4 (527)	20-3/4 (527)	20-3/4 (527)	32-3/4 (832)	32-3/4 (832)	32-3/4 (832)	50-3/4 (1289)	50-3/4 (1289)	50-3/4 (1289)
"C" Width to Centerline Flue	13-3/8 (340)	13-3/8 (340)	13-3/8 (340)	19-3/8 (492)	19-3/8 (492)	19-3/8 (492)	28-3/8 (721)	28-3/8 (721)	28-3/8 (721)
"D" Depth to Front Hanger	21 (533)	21 (533)	21 (533)	21 (533)	21 (533)	21 (533)	21 (533)	21 (533)	21 (533)
"E" Hanging Distance Width	18-5/8 (473)	18-5/8 (473)	18-5/8 (473)	30-5/8 (778)	30-5/8 (778)	30-5/8 (778)	48-5/8 (1235)	48-5/8 (1235)	48-5/8 (1235)
"F" Hanging Distance Depth	19 (483)	19-1/2 (495)	19-1/2 (495)	32-3/4 (832)	32-3/4 (832)	32-3/4 (832)	23-1/2 (597)	32-3/4 (832)	32-3/4 (832)
"G" Discharge Opening Width	18-3/4 (476)	18-3/4 (476)	18-3/4 (476)	30-3/4 (781)	30-3/4 (781)	30-3/4 (781)	48-3/4 (1238)	48-3/4 (1238)	48-3/4 (1238)
"H" Depth to Centerline Flue	4-3/4 (121)	4-3/4 (121)	4-3/4 (121)	4-3/4 (121)	4-3/4 (121)	4-3/4 (121)	5-1/8 (130)	5-1/8 (130)	5-1/8 (130)
"M" Overall Unit Width	25-1/4 (641)	25-1/4 (641)	25-1/4 (641)	37-1/4 (946)	37-1/4 (946)	37-1/4 (946)	55-1/4 (1403)	55-1/4 (1403)	55-1/4 (1403)
"P" Overall Unit Depth	49-3/4 (1264)	49-3/8 (1254)	49-3/8 (1254)	56-1/8 (1426)	56-1/8 (1426)	56-1/8 (1426)	53-3/8 (1356)	56-1/8 (1426)	56-1/8 (1426)
*Flue Size Diameter - inch (mm)	5 (127)	5 (127)	5 (127)	5 (127)	5 (127)	5 (127)	6 (152)	6 (152)	6 (152)
Gas Inlet, Natural Gas - inch	1/2	1/2	1/2	1/2	1/2	1/2	3/4	3/4	3/4
Gas Inlet, LP Gas - inch	1/2	1/2	1/2	1/2	1/2	1/2	3/4	3/4	3/4
Approximate Unit Weight - lb (kg)	173 (78)	177 (80)	204 (92)	248 (112)	267 (121)	292 (132)	374 (170)	394 (179)	433 (196)
Approximate Ship Weight - lb (kg)	258 (117)	263 (119)	291 (132)	384 (174)	403 (183)	428 (194)	524 (238)	551 (250)	599 (272)

† Ratings shown are for unit installations at elevations between 0 and 2,000 feet (0 to 610m). For unit installations in U.S.A. above 2,000 feet (610m), the unit input must be field derated 4% for each 1,000 feet (305m) above sea level; refer to local codes, or in absence of local codes, refer to the latest edition of the National Fuel Gas Code, ANSI Standard Z223.1 (NFPA No. 54).

For installations in Canada, any reference to deration at altitudes in excess of 2,000 feet (610m) are to be ignored. At altitudes of 2,000 feet to 4,500 feet (610 to 1372m), the unit must be field derated and be so marked in accordance with the ETL certification. See unit installation manual for field deration information.

* Flue collar is factory supplied with unit; to be field installed per included instructions.

** LEGEND: SPH = SPLIT PHASE CAP. START = CAPACITOR START ODP = OPEN DRIP PROOF

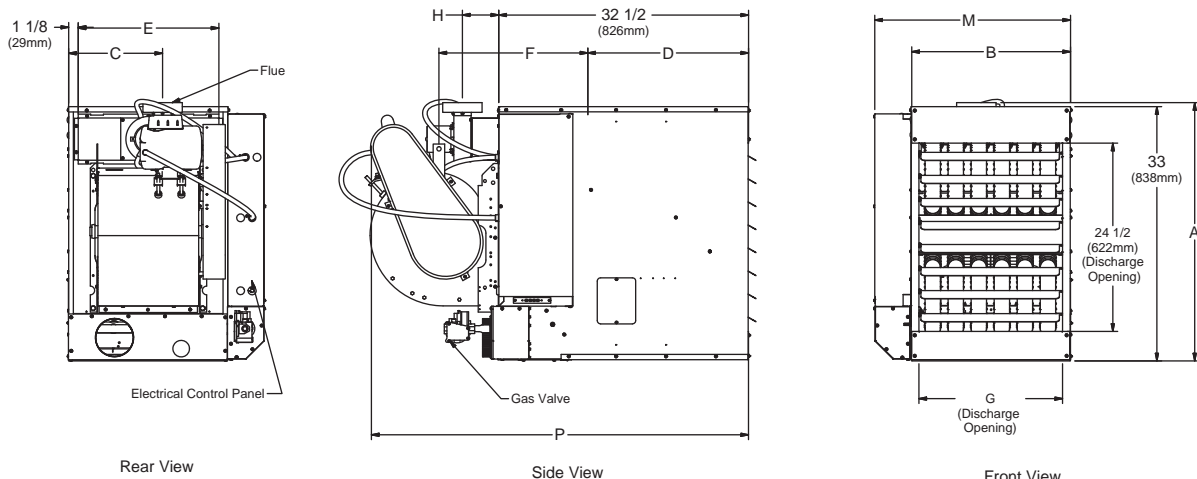

D9050B

"BSC" SERIES BLOWER PERFORMANCE DATA

Model	Temp.Rise °F (°C)	CFM (cu. m/s)	External Static Pressure in. W.C. (kPa)									
			0.1" (0.02)		0.2" (0.05)		0.3" (0.07)		0.4" (0.10)		0.5" (0.12)	
			RPM	HP (kW)	RPM	HP (kW)	RPM	HP (kW)	RPM	HP (kW)	RPM	HP (kW)
BSC100	50° (10)	1535 (0.724)	804	½ (0.37)	860	½ (0.37)	927	½ (0.37)	989	½ (0.37)	1045	½ (0.37)
	60° (15.5)	1279 (0.603)	649	¼ (0.19)	760	¼ (0.19)	821	¼ (0.19)	890	¼ (0.19)	963	¼ (0.19)
	70° (21.1)	1096 (0.517)	633	¼ (0.19)	700	¼ (0.19)	779	¼ (0.19)	858	¼ (0.19)	920	¼ (0.19)
	80° (26.6)	959 (0.452)	591	¼ (0.19)	665	¼ (0.19)	733	¼ (0.19)	801	¼ (0.19)	869	¼ (0.19)
BSC125	50° (10)	1919 (0.905)	703	½ (0.37)	758	½ (0.37)	810	½ (0.37)	863	½ (0.37)	918	½ (0.37)
	60° (15.5)	1599 (0.754)	608	½ (0.37)	685	½ (0.37)	741	½ (0.37)	790	½ (0.37)	843	½ (0.37)
	70° (21.1)	1371 (0.647)	558	½ (0.37)	626	½ (0.37)	694	½ (0.37)	755	½ (0.37)	798	½ (0.37)
	80° (26.6)	1199 (0.565)	580	½ (0.37)	597	½ (0.37)	649	½ (0.37)	720	½ (0.37)	779	½ (0.37)
BSC150	50° (10)	2303 (1.087)	853	½ (0.37)	927	½ (0.37)	962	½ (0.37)	988	½ (0.37)	1040	½ (0.37)
	60° (15.5)	1919 (0.905)	755	½ (0.37)	810	½ (0.37)	845	½ (0.37)	894	½ (0.37)	939	½ (0.37)
	70° (21.1)	1645 (0.776)	649	½ (0.37)	726	½ (0.37)	790	½ (0.37)	836	½ (0.37)	876	½ (0.37)
	80° (26.6)	1439 (0.679)	616	½ (0.37)	670	½ (0.37)	720	½ (0.37)	785	½ (0.37)	840	½ (0.37)
BSC175	50° (10)	2687 (1.26)	522	¾ (0.56)	566	¾ (0.56)	612	¾ (0.56)	652	¾ (0.56)	688	¾ (0.56)
	60° (15.5)	2239 (1.05)	468	¾ (0.56)	514	¾ (0.56)	564	¾ (0.56)	609	¾ (0.56)	654	¾ (0.56)
	70° (21.1)	1919 (0.905)	423	¾ (0.56)	471	¾ (0.56)	527	¾ (0.56)	582	¾ (0.56)	624	¾ (0.56)
	80° (26.6)	1697 (0.8)	402	¾ (0.56)	482	¾ (0.56)	515	¾ (0.56)	567	¾ (0.56)	609	¾ (0.56)
BSC200	50° (10)	3071 (1.44)	592	¾ (0.56)	627	¾ (0.56)	670	¾ (0.56)	702	¾ (0.56)	748	¾ (0.56)
	60° (15.5)	2559 (1.2)	526	¾ (0.56)	561	¾ (0.56)	597	¾ (0.56)	647	¾ (0.56)	688	¾ (0.56)
	70° (21.1)	2193 (1.03)	468	¾ (0.56)	519	¾ (0.56)	556	¾ (0.56)	612	¾ (0.56)	653	¾ (0.56)
	80° (26.6)	1919 (0.905)	432	¾ (0.56)	481	¾ (0.56)	537	¾ (0.56)	593	¾ (0.56)	638	¾ (0.56)
BSC250	50° (10)	3839 (1.81)	734	1 (0.75)	766	1 (0.75)	802	1 ½ (1.11)	836	1 ½ (1.11)	863	1 ½ (1.11)
	60° (15.5)	3199 (1.51)	626	1 (0.75)	668	1 (0.75)	700	1 (0.75)	749	1 (0.75)	780	1 (0.75)
	70° (21.1)	2742 (1.29)	545	1 (0.75)	593	1 (0.75)	633	1 (0.75)	680	1 (0.75)	718	1 (0.75)
	80° (26.6)	2399 (1.13)	494	1 (0.75)	555	1 (0.75)	590	1 (0.75)	642	1 (0.75)	680	1 (0.75)
BSC300	50° (10)	4551 (2.14)	734	1 (0.75)	766	1 (0.75)	802	1 ½ (1.11)	836	1 ½ (1.11)	863	1 ½ (1.11)
	60° (15.5)	3792 (1.79)	626	1 (0.75)	668	1 (0.75)	700	1 (0.75)	749	1 (0.75)	780	1 (0.75)
	70° (21.1)	3259 (1.53)	545	1 (0.75)	593	1 (0.75)	633	1 (0.75)	680	1 (0.75)	718	1 (0.75)
	80° (26.6)	2844 (1.34)	494	1 (0.75)	555	1 (0.75)	590	1 (0.75)	642	1 (0.75)	680	1 (0.75)
BSC350	50° (10)	5374 (2.54)	558	1 ½ (1.11)	598	1 ½ (1.11)	638	1 ½ (1.11)	676	1 ½ (1.11)	727	1 ½ (1.11)
	60° (15.5)	4478 (2.11)	484	1 ½ (1.11)	532	1 ½ (1.11)	588	1 ½ (1.11)	653	1 ½ (1.11)	680	1 ½ (1.11)
	70° (21.1)	3839 (1.81)	451	1 ½ (1.11)	503	1 ½ (1.11)	559	1 ½ (1.11)	609	1 ½ (1.11)	654	1 ½ (1.11)
	80° (26.6)	3359 (1.59)	408	1 ½ (1.11)	480	1 ½ (1.11)	536	1 ½ (1.11)	589	1 ½ (1.11)	621	1 ½ (1.11)
BSC400	50° (10)	6142 (2.9)	647	1 ½ (1.11)	659	1 ½ (1.11)	670	1 ½ (1.11)	713	1 ½ (1.11)	751	2 (1.49)
	60° (15.5)	5118 (2.41)	553	1 ½ (1.11)	570	1 ½ (1.11)	618	1 ½ (1.11)	653	1 ½ (1.11)	697	1 ½ (1.11)
	70° (21.1)	4387 (2.07)	483	1 ½ (1.11)	523	1 ½ (1.11)	568	1 ½ (1.11)	615	1 ½ (1.11)	660	1 ½ (1.11)
	80° (26.6)	3839 (1.81)	437	1 ½ (1.11)	490	1 ½ (1.11)	547	1 ½ (1.11)	589	1 ½ (1.11)	655	1 ½ (1.11)