

# Submittal Data Sheet

## COR MVI - Pressure Boosting Systems



### Wilco COR-2 MVI-15



Project:	
Engineer:	
Contractor:	
Submitted By:	Date:
Approved By:	Date:

Tag #	Model #	Flow	Set PSI	Min. Inlet PSI	HP/Pump	Phase	Voltage	RPM
						3		3450

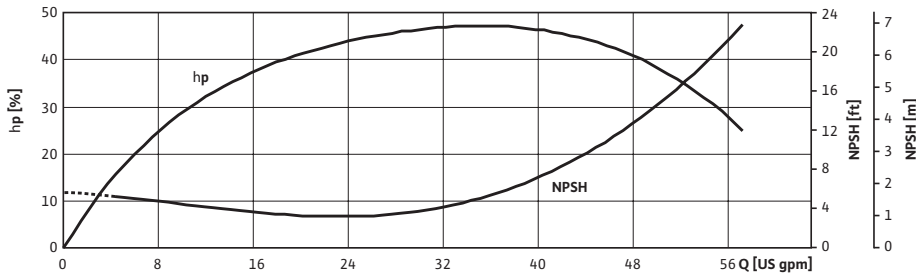
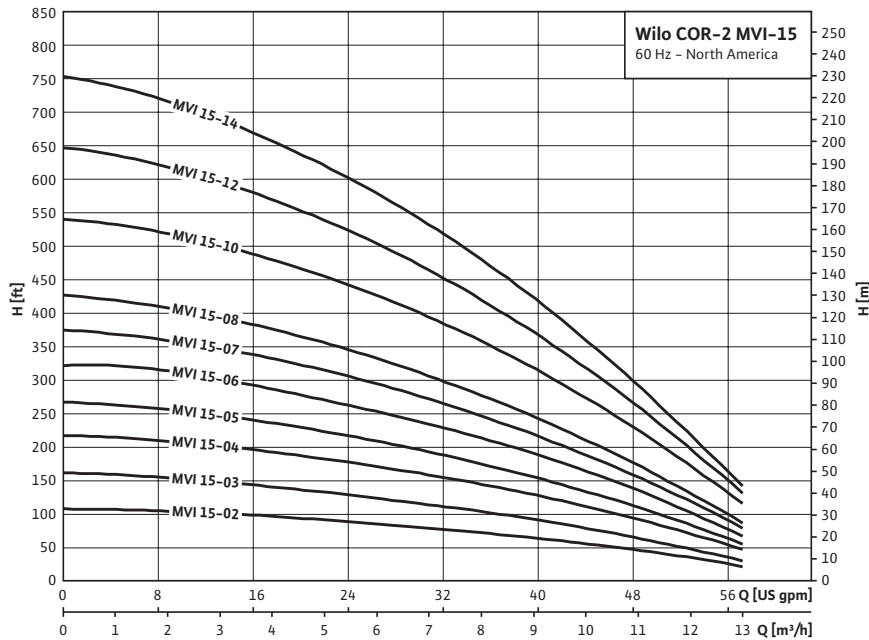

Technical Data - System	
Liquid Temp Range	30°F to 200°F (-1°C to 120°C)
Power Supply	3- 208-230/460/575
Ambient Temperature Limits	Maximum 104°F
Header Connection	2" NPT
Max Inlet Pressure	145 PSI
Max System Pressure	250 PSI
Motor Options	TEFC Standard

Technical Data - Panel	
Enclosure	NEMA 12
User Interface	3 color touch screen
Frequency Converter (VFD)	FC 202
CPU	24v
Pressure Transducer	4-20 mA Stainless Steel 1/4" NPT

Materials of Construction	
Pump Volute	Stainless steel AISI 304 (1.4301)
Impeller	Stainless steel AISI 304 (1.4301)
Shaft	Stainless steel AISI 304 (1.4301)
Header	Stainless steel AISI 316 (1.4404)
Elastomers	EPDM
Mechanical Seal	Carbon/Tungsten Carbide, SiC/Carbon
Bearing	Tungsten Carbide/Ceramic
System Base	Steel
Vibration Isolators	Neoprene, height adjustable

Approval Stamp

### Wilco COR-2 MVI-15

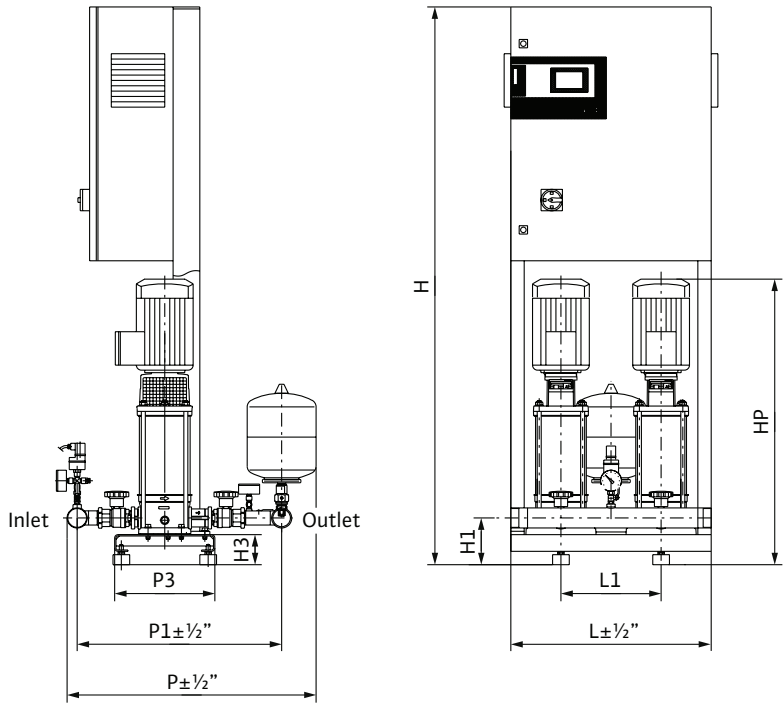

Dimensions and Weights											TEFC Motor Data			
Model	Dimensions-inches (mm)									Weight lbs (kg)	P2	Phase	Voltage	FLA (per pump)
	H	H <sub>1</sub>	H <sub>3</sub>	H <sub>p</sub>	L	L <sub>1</sub>	P	P <sub>1</sub>	P <sub>3</sub>		[HP]	[~]	[V]	[A]
COR-2 MVI-15-02	70 (1778)	6½ (165)	3¾/16 (90)	31 (787)	23½ (597)	11¾ (298)	32 (813)	26 (660)	11¾ (298)	190 (86)	1	3	208/230/460/575	4.1-3.6/1.8/1.4
COR-2 MVI-15-03	70 (1778)	6½ (165)	3¾/16 (90)	32 (813)	23½ (597)	11¾ (298)	32 (813)	26 (660)	11¾ (298)	195 (88)	1	3	208/230/460/575	4.1-3.6/1.8/1.4
COR-2 MVI-15-04	70 (1778)	6½ (165)	3¾/16 (90)	33 (838)	23½ (597)	11¾ (298)	32 (813)	26 (660)	11¾ (298)	200 (91)	1½	3	208/230/460/575	4.9-4.6/2.3/1.8
COR-2 MVI-15-05	70 (1778)	6½ (165)	3¾/16 (90)	34 (864)	23½ (597)	11¾ (298)	32 (813)	26 (660)	11¾ (298)	205 (93)	2	3	208/230/460/575	6.2-5.8/2.9/2.2
COR-2 MVI-15-06	70 (1778)	6½ (165)	3¾/16 (90)	36 (914)	23½ (597)	11¾ (298)	32 (813)	26 (660)	11¾ (298)	205 (93)	2	3	208/230/460/575	6.2-5.8/2.9/2.2
COR-2 MVI-15-07	70 (1778)	6½ (165)	3¾/16 (90)	37 (940)	23½ (597)	11¾ (298)	32 (813)	26 (660)	11¾ (298)	210 (95)	3	3	208/230/460/575	8.1-7.6/3.8/3
COR-2 MVI-15-08	70 (1778)	6½ (165)	3¾/16 (90)	38 (965)	23½ (597)	11¾ (298)	32 (813)	26 (660)	11¾ (298)	220 (100)	3	3	208/230/460/575	8.1-7.6/3.8/3
COR-2 MVI-15-10	70 (1778)	6½ (165)	3¾/16 (90)	43 (1092)	23½ (597)	11¾ (298)	32 (813)	26 (660)	11¾ (298)	225 (102)	5	3	208/230/460/575	13.2-12/6/4.8
COR-2 MVI-15-12	70 (1778)	6½ (165)	3¾/16 (90)	45 (1143)	23½ (597)	11¾ (298)	32 (813)	26 (660)	11¾ (298)	245 (111)	5	3	208/230/460/575	13.2-12/6/4.8
COR-2 MVI-15-14	70 (1778)	6½ (165)	3¾/16 (90)	47 (1194)	23½ (597)	11¾ (298)	32 (813)	26 (660)	11¾ (298)	270 (122)	5	3	208/230/460/575	13.2-12/6/4.8