

*DesignLine*  
**THERMAQUIET™**



**LOW TEMPERATURE  
HIGH EFFICIENCY  
HYDRONIC FAN COIL**

# MEETING TODAY'S GREEN INITIATIVES...

ThermaQuiet, Designline's new high efficiency hydronic heating unit brings sleek European styling to any residential or light commercial application including new construction and retrofits.

ThermaQuiet is designed to perfectly complement today's condensing applications providing superior outputs and performance at reduced supply water temperatures, maximizing equipment performance efficiencies. Whether using a high efficiency boiler, heat pump or even solar hot water supply products, ThermaQuiet's energy efficient design saves over 35% when compared to traditional hydronic radiation products.

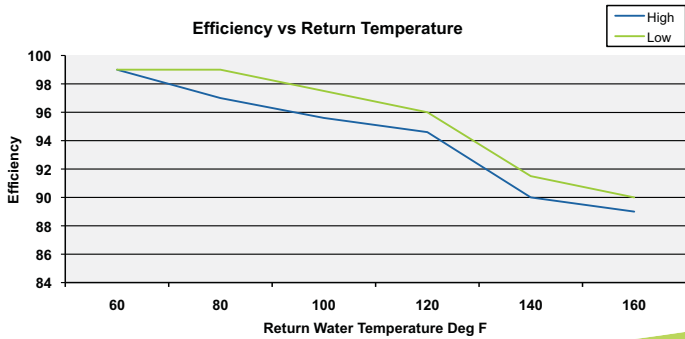

When used in a low temperature application or a traditional 180° hot water supply temperature system ThermaQuiet's uniquely designed coil produces the most efficient heat distribution on the market today.

ThermaQuiet is the perfect alternative to bulky radiators, expensive in-floor radiant or any other hydronic-based space heating application providing not only superior performance but also style to match any décor.

All units are controlled through a simple to use integrated micro-processor control platform that continuously monitors room temperatures through temperature compensation, minimizing energy consumption while maximizing operating efficiencies.



## FEATURES AND BENEFITS

- Attractive Stylish Design
  - Solar & Heat Pump Compatible
  - Microprocessor Control Platform
  - Insta-Heat “Boost” Function
  - Diagnostic & Performance LED Indicators
- Simple Low Cost Installation
  - Cool-Touch Exterior
  - 3,000 – 14,340 BTU/h
    - Replaces up to 25' of Traditional Baseboard



ThermaQuiet units are available in 2 sizes with output capacity ranges from 3,000 – 14,340 BTU/h. “Insta-Heat”, ThermaQuiet’s override function, allows an immediate override of programmed settings for an instant heat “boost” at the touch of a button. For the summer months the “Insta-Heat” setting override allows for no heat air circulation for passive summer cooling.

### EFFICIENT HEAT DISTRIBUTION

An engineered fan design with curved impeller is used as opposed to conventional tangential fans, which just directionally “blow” air. ThermaQuiet’s fan assembly generates pressure equally in all directions for uniform, precise tempered air distribution to the occupied space. Assemblies are perfectly balanced insuring silent operation for the life of the unit.

### COMFORT AT YOUR FINGERTIPS

ThermaQuiet’s proprietary micro-processor control platform allows for custom setting overrides and LED light indicators provide immediate performance feedback.

### GREEN...

ThermaQuiet is **GREEN** and extremely efficient. Incorporating the ThermaQuiet into any condensing boiler application allows boilers to run at optimal efficiencies. ThermaQuiet’s low draw electrical configuration further promotes extreme efficiency. Standard units consume between 8-34 watts, which is equivalent to that of a small reading lamp!

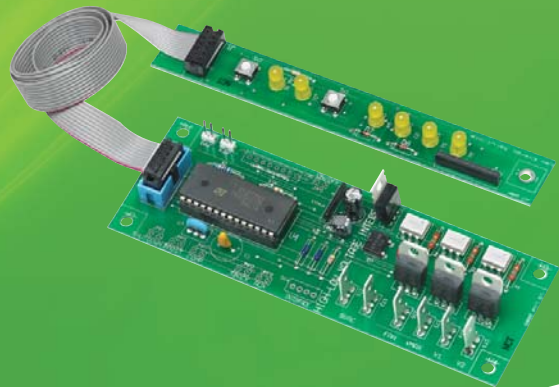



# SPECIFICATIONS

**DL65-WM**

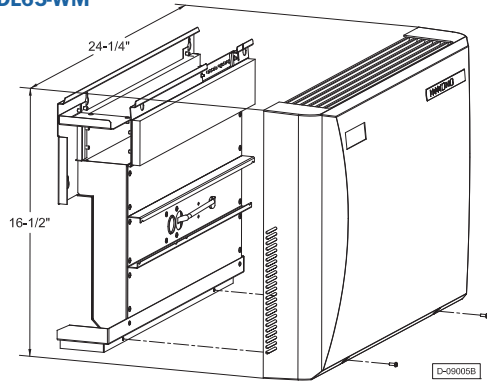

**DL145-WM**

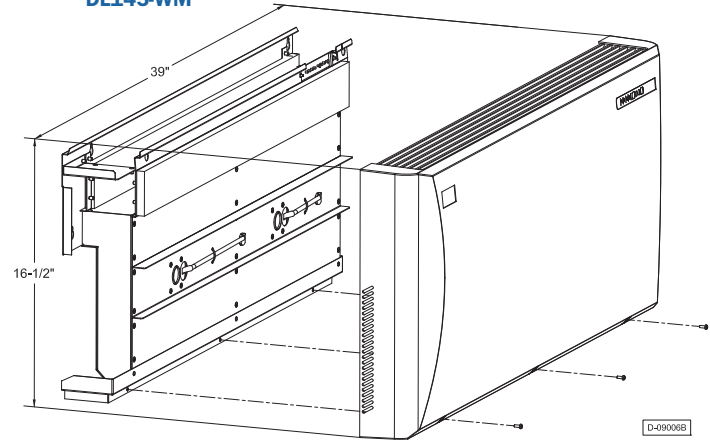

**Entering Water Temperature (°F)**

	<b>GPM</b>	<b>Fan Speed</b>	<b>120°F</b>	<b>130°F</b>	<b>140°F</b>	<b>150°F</b>	<b>160°F</b>	<b>170°F</b>	<b>180°F</b>
<b>DL65-WM</b>	<b>1</b>	<b>Low</b>	1402	1926	2487	2971	3296	3550	3858
		<b>Medium</b>	2049	2628	3158	3756	4057	4333	4609
		<b>Boost</b>	2876	3358	3922	4644	5144	5693	6487
	<b>4</b>	<b>Low</b>	1584	2176	2810	3357	3724	4012	4360
		<b>Medium</b>	2315	2970	3569	4244	4584	4896	5208
		<b>Boost</b>	3250	3795	4432	5248	5813	6433	7330
<b>DL145-WM</b>	<b>1</b>	<b>Low</b>	3152	3877	4501	5463	6855	7654	8195
		<b>Medium</b>	4923	5388	6845	8536	9192	10258	11609
		<b>Boost</b>	5805	6215	8352	10243	11865	12951	14340
	<b>4</b>	<b>Low</b>	3562	4381	5086	6173	7746	8649	9260
		<b>Medium</b>	5563	6088	7735	9646	10387	11592	13118
		<b>Boost</b>	6560	7023	9438	11575	13407	14635	16204

BTU/hr Output based on 65° entering air

	<b>DL65-WM</b>		<b>DL145-WM</b>	
	<b>Low</b>	<b>High</b>	<b>Low</b>	<b>High</b>
<b>CFM</b>	29	36	59	118
<b>Voltage</b>	115		115	
<b>dBa</b>	22	33	22	33
<b>Velocity (ft/sec)</b>	1.31	2.30	1.48	2.23
<b>Dimensions</b>	16.14H x 24W x 4.25D		16.14H x 38.78W x 4.25D	

\*In the interest of product improvement we reserve the right to make product changes without notice.

*DesignLine*

260 North Elm Street, Westfield, MA 01085  
Tel: (413) 564-5545 Fax: (413) 572-3764

7555 Tranmere Drive, Mississauga, Ontario, L5S 1L4 Canada  
Tel: (905) 672-2991 Fax: (905) 672-2883



[www.designlineonline.com](http://www.designlineonline.com)

DL-TQ-1R