



FlexCore Symmetrical Firetube boilers bring hydronic heating products to unprecedented levels of operating efficiency.

Unlike other manufacturers; from start to finish FlexCore was designed, developed and engineered by the experts at RBI.

Engineered for performance and longevity, FlexCore utilizes a perfectly temperature balanced heat exchanger that provides not only the highest efficiencies but also a durability beyond that of any competitive firetube boiler on the market.

Features and Benefits

- 96.8% AHRI Certified
- Up to 99% Maximum Efficiency
- Symmetrical Firetube Heat Exchanger
- Variable Volume Flow
- Full Modulation
- Patented "Turbo Pilot" Ignition
- HeatNet 3.0 Integrated Control Platform
- Touchscreen Programming & Diagnostics
- Low NO_x & CO
- Modern Jacket Design
- Premium Efficiency
- Superior Durability
- Easy Installation & Maintenance



Innovative Heat Exchanger Design

Maximum uniform heat transfer is obtained through the symmetrical heat exchanger design that "scrubs" every last bit of heat out of the combustion gases resulting in unparalleled efficiencies in a small compact footprint while absorbing all expansion and contraction with no stress on the tubes.

Manufactured using 304 stainless steel tubes are located around a center core keeping perfect temperature symmetry across the tubes thus eliminating intra-tubular stress found in other designs. The heat exchangers high density design allows for fewer tubes with increased BTUs resulting in a compact footprint.

ASME certified for water heating and space heating and built to the most stringent tolerances available today.

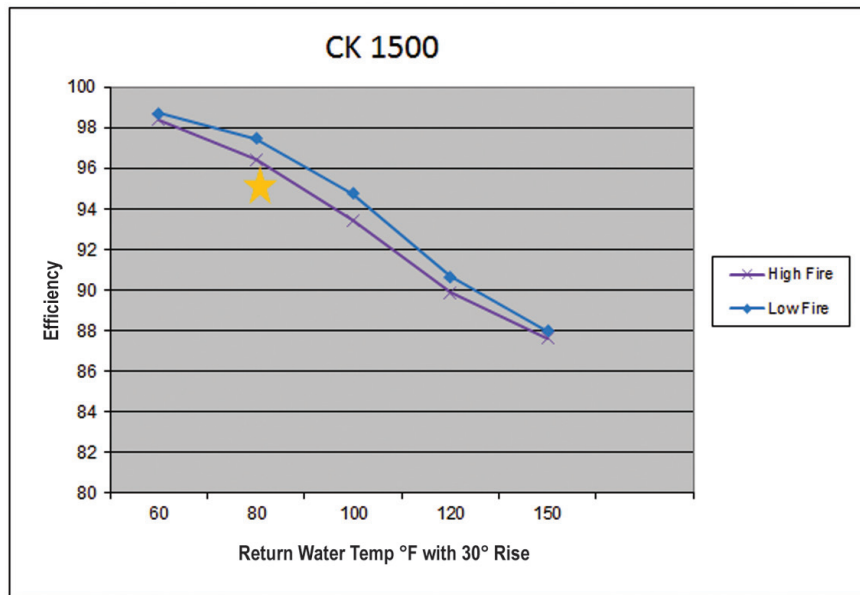
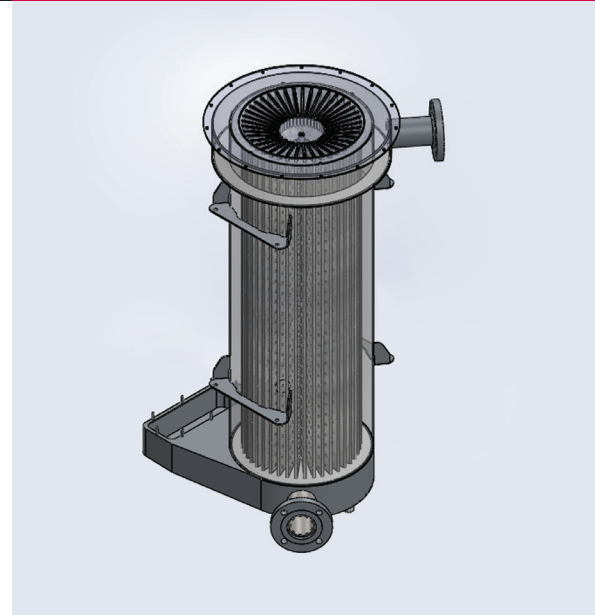

★ 95.1% AHRI Certified Product Performance Thermal Efficiency



260 North Elm Street, Westfield, MA 01085

Tel. (413) 568-9571 Fax (413) 568-9613

7555 Tranmere Drive, Mississauga, Ontario L5S 1L4

Tel. (905) 670-5888 Fax (905) 670-5782

www.rbiwaterheaters.com

