

STORAGE TANKS

VERTICAL GLASS LINED JACKETED AND INSULATED OR BARE ASME

RBI tanks are designed for the efficient, heat retaining storage of hot water supply systems. Ranging in size from 200 – 1,000* gallon capacities RBI's storage tanks offer complete application flexibility and are the perfect complement to RBI's high efficiency water heaters and boilers.

Available in both jacketed/insulated and bare configurations all RBI storage tanks are ASME certified and use the latest advancements in interior tank lining technology for maximum performance and durability. **Ultonium®**, RBI's glass-lining is specifically formulated for hot water applications and provides an ultra-durable wear resistant lining that minimizes the effects of high temperatures associated with water heating.

RBI storage tanks provide advanced engineering, quality materials, premium performance and long service life to any water heating application.



STORAGE TANKS – BARE – VERTICAL GLASS LINED			
Model	Capacity (Gals.)	Height	Width
V200B	200	79.5"	28"
V240B	240	89"	30"
V310B	310	82"	36"
V435B	435	85"	42"
V505B	505	97"	42"
V675B	675	100"	48"
V860B	860	124"	48"

STORAGE TANKS – JACKETED – VERTICAL GLASS LINED			
Model	Capacity (Gals.)	Height	Width
V200J	200	78"	32"
V240J	240	93"	34"
V310J	310	86"	40"
V435J	435	89"	46"
V505J	505	101"	46"
V675J	675	104"	52"
V840J	840	128"	52"

- ASME Certified HLW Stamp
- Ultonium® Vitreous Glass Lining
- 2" True Dielectric NPT Fittings
- 125 PSI Certified Working Pressure
- Magnesium Anode Rods
- Heavy Gauge Steel Construction
- 2" Non-CFC Foam Insulation
- Durable Heavy Gauge Steel Jacket
- 5-Year Warranty
- 10-Year Warranty (Double Glass Lining Only)

STORAGE TANKS

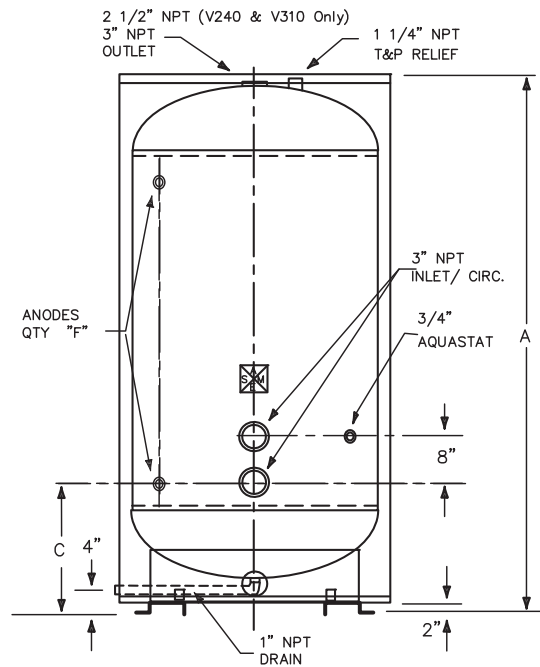
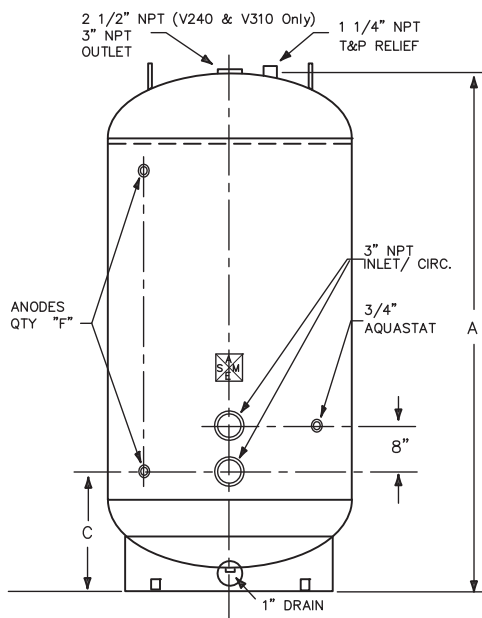
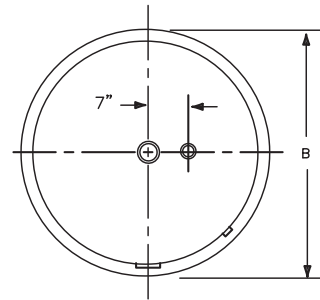
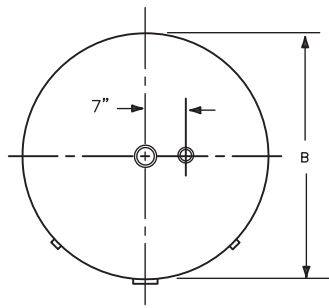

STORAGE TANKS – BARE — DIMENSIONS					
Model	"A"	"B"	"C"	"F"	Weight (lbs.)
V200B*	79.5"	28"	11-1/8"	2	210
V240B	89"	30"	17-1/2"	2	383
V310B	82"	36"	19"	2	527
V435B	85"	42"	20-1/2"	2	695
V505B	97"	42"	20-1/2"	3	779
V675B	100"	48"	22"	3	1,173
V860B	124"	48"	22"	3	1,428

JACKETED — DIMENSIONS					
Model	"A"	"B"	"C"	"F"	Weight (lbs.)
V200J*	78"	32"	11-3/4"	2	541
V240J	93"	34"	19-1/2"	2	539
V310J	86"	40"	21"	2	710
V435J	89"	46"	22-1/2"	2	917
V505J	101"	46"	22-1/2"	3	1,017
V675J	104"	52"	24"	3	1,456
V840J	128"	52"	24"	3	1,748

*150 P.S.I. standard – see submittal sheet (RBSS-6) for specific drawing.
 NOTE: Tanks shown are rated for 125 M.A.W.P.
 Standard: 125 P.S.I. Consult factory for optional working pressures.
 Consult factory for tanks larger than 860 gallons.



7555 Tranmere Drive, Mississauga, Ontario L5S 1L4
 Tel. (905) 670-5888 Fax (905) 670-5782

260 North Elm Street, Westfield, MA 01085
 Tel. (413) 568-9571 Fax (413) 568-9613

In the interest of product improvement, RBI reserves the right to make changes without notice.

A MESTEK COMPANY www.rbiwaterheaters.com