

NB-6P Condensate PH Treatment Tank

Rev 10/2/15

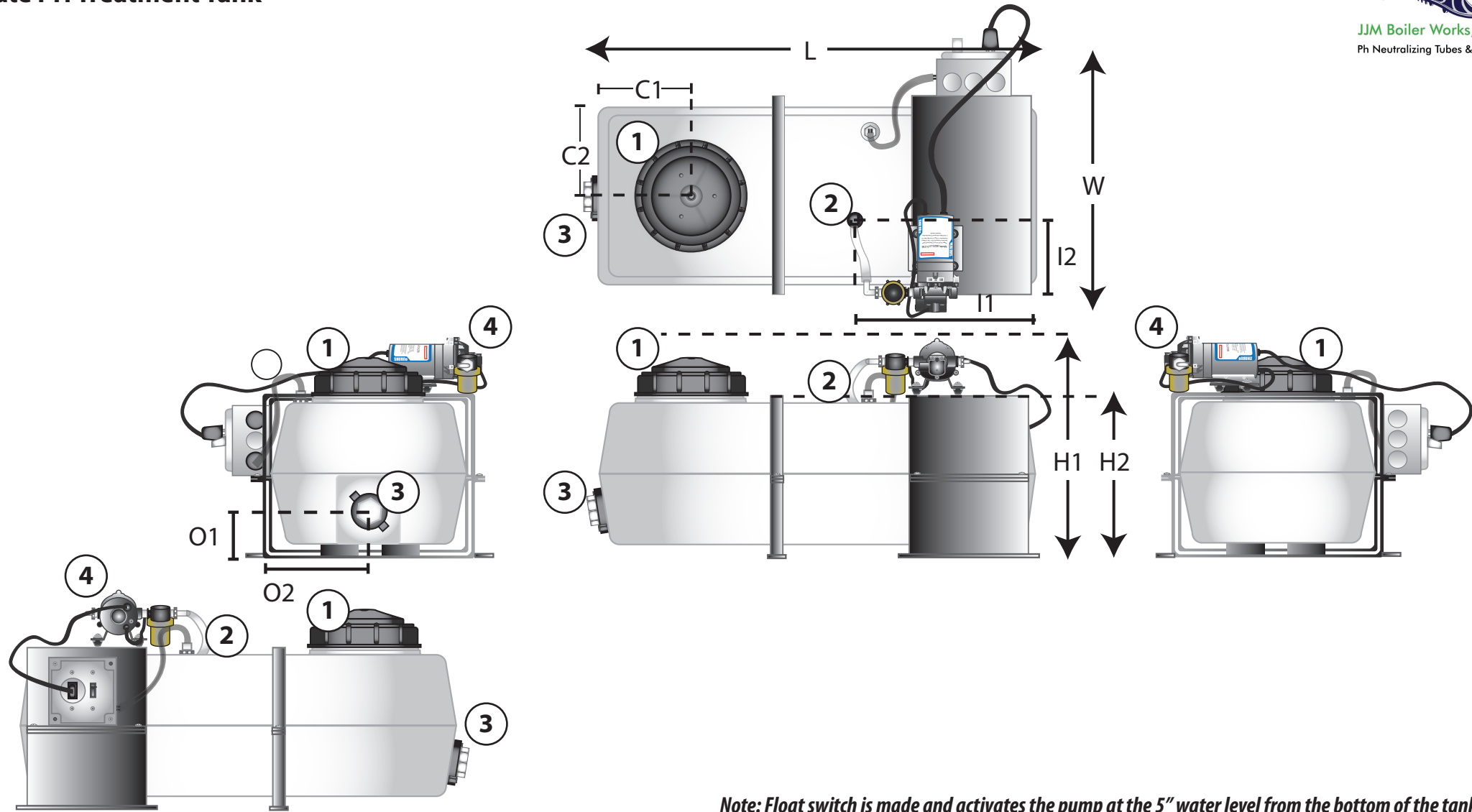

JJM Boiler Works, Inc.
Ph Neutralizing Tubes & Tanks



Note: Float switch is made and activates the pump at the 5" water level from the bottom of the tank.

Ratings & Dimensions (in inches)																
Model	MBH	GPH	L	W	H1	H2	①	C1	C2	②	I1	I2	③	O1	④	O2
NB-6P	6000	48	22	14 1/4	12 3/4	8 3/8	Cap 5" port	4	4 3/4	Inlet 3/4" port	7	9 1/2	Inlet 1" port	1 3/4	Outlet 3/8" port	4 1/2