

CODE OPTIONS

CSD-1	STANDARD
--------------	----------

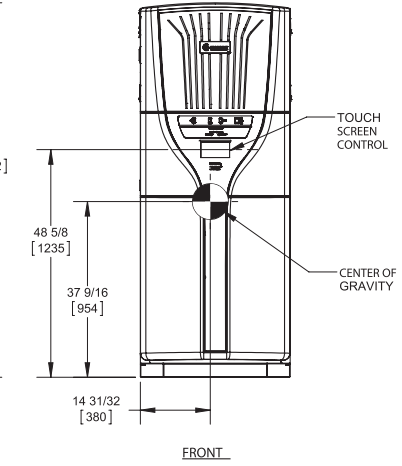
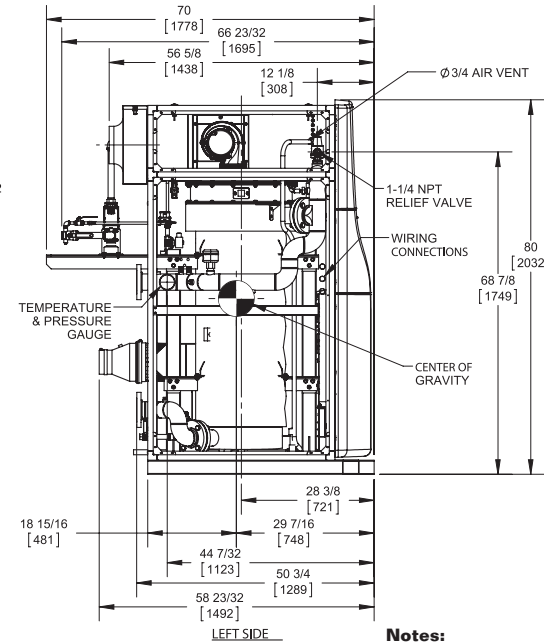
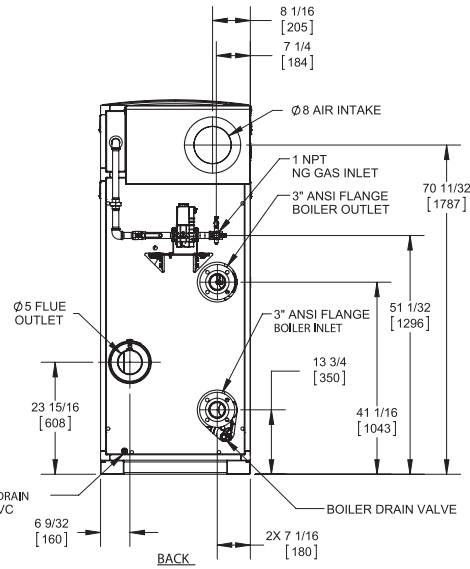
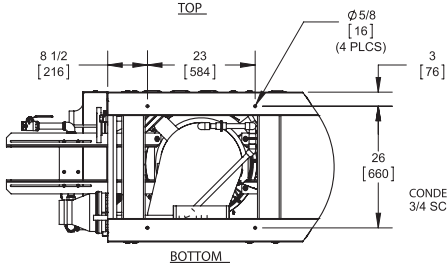
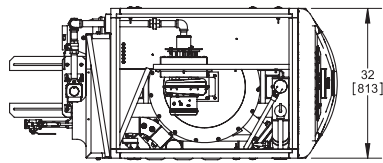

Notes:

1. Dimensions are approximate and should not be used to "rough-in" equipment.
2. Dimensions are subject to change without notice.
3. All dimensions are in inches (mm).

BOILER CERTIFIED RATINGS & CAPACITIES

Fuel Type	Natural Gas	Boiler FLA	9.5*
Input BTU/hr.	850,000 / 249 KW	Boiler HP	24.3
Output BTU/hr.	811,750 / 238 KW	Min. Gas Pressure Required	3" W.C.
Electrical Requirements	120 VAC/60 Hz/1PH (with neutral)	Max. Gas Pressure Allowed	14" W.C.
		Operating Weight	1655 lbs. / 750.7 kg.

BOILER TRIM & CONTROLS

Main Gas Valve	Dungs MBC	Air Switch	Huba
Firing Valve	1" Apollo	Flow Switch	SIKA VK306
Ignition Control	Honeywell RM7895C	Blocked Flue Switch	Cleveland NS2
Operating Control	HeatNet®	Blower Motor	Ametek
High Limit	Jumo	L.W.C.O.	800
Main Ball Valve	1" Apollo	Relief Valve	1" x 1-1/4" set @ 50 psi
Pilot Cock	1/4"	Pilot Regulator	White-Rodgers

A.S.M.E.

ASME Sect IV Fire Side	82 Sq. Ft. / 7.62 Sq. M.	Design Data	Max. 160 psig & 210°F
Htg Surface		Water Volume	42 gal. / 160 Liters
ASME Sect IV Water Side	85 Sq. Ft. / 7.90 Sq. M.		
Htg Surface			
CV. GPM (1PSID)	87		

* Add circulator amps.

BOILER TEMPERATURE RISE / PRESSURE DROP (Based on Full Input)

20°F / 11.1°C		40°F / 22.2°C		60°F / 33.3°C		80°F / 44.4°C		100°F / 55.5°C											
Flow Rate	Pressure Drop	Flow Rate	Pressure Drop	Flow Rate	Pressure Drop	Flow Rate	Pressure Drop	Flow Rate	Pressure Drop										
GPM	L/s	Ft	kPa	GPM	L/s	Ft	kPa	GPM	L/s	Ft	kPa	GPM	L/s	Ft	kPa	GPM	L/s	Ft	kPa
81.2	5.1	2.0	6.0	40.6	2.6	0.5	1.5	27.1	1.7	0.2	0.7	20.3	1.3	0.1	0.4	16.2	1.0	0.1	0.2

Flow GPM		Temp. Rise** (°F)		Vent Length (Equiv. Ft.)		Air Inlet Length (Equiv. Ft.)	
Min	Max	Min	Max	Min	Max	Min	Max
16.2	81.2	20	100	6	100	0	100

** Min/Max delta t reflects boiler operation at full input. For applications requiring operation above/below these parameters please consult factory.

REP FIRM _____
 SUBMITTED BY _____
 JOB NAME _____
 ARCHITECT _____
 ENGINEER _____
 CONTRACTOR _____
 DATE _____

FlexCore 850

Category II or Category IV Appliance
 (see Installation and Operation Manual for venting information)

RBI®
 RELIABLE. BOLD. INNOVATIVE.

A Division of Mestek, Inc.
 Westfield, MA 01085
 (413) 568-9571