



Finned Copper Tube Gas Boilers (MB6000, MB8000, MB10000)

Boiler Manual *Installation and Operation Instructions*

Also read and follow:
HeatNet Control Manual



WARNING This manual is intended only for use by a qualified heating installer/technician. Read and follow this manual, all supplements and related instructional information provided with the boiler. Install, start and service the boiler only in the sequence and methods given in these instructions. Failure to do so can result in severe personal injury, death or substantial property damage.

WARNING **Do not use the boiler during construction.** Construction dust and particulate, particularly drywall dust, will cause contamination of the burner, resulting in possible severe personal injury, death or substantial property damage. The boiler can only be operated with a dust-free air supply. Follow the instruction manual procedures to duct air to the boiler air intake. If the boiler has been contaminated by operation with contaminated air, follow the instruction manual guidelines to clean, repair or replace the boiler if necessary.

CAUTION Affix these instructions near to the boiler. Instruct the building owner to retain the instructions for future use by a qualified service technician, and to follow all guidelines in the User's Information Manual.

RBI Futera XLF-Series boilers — Overview

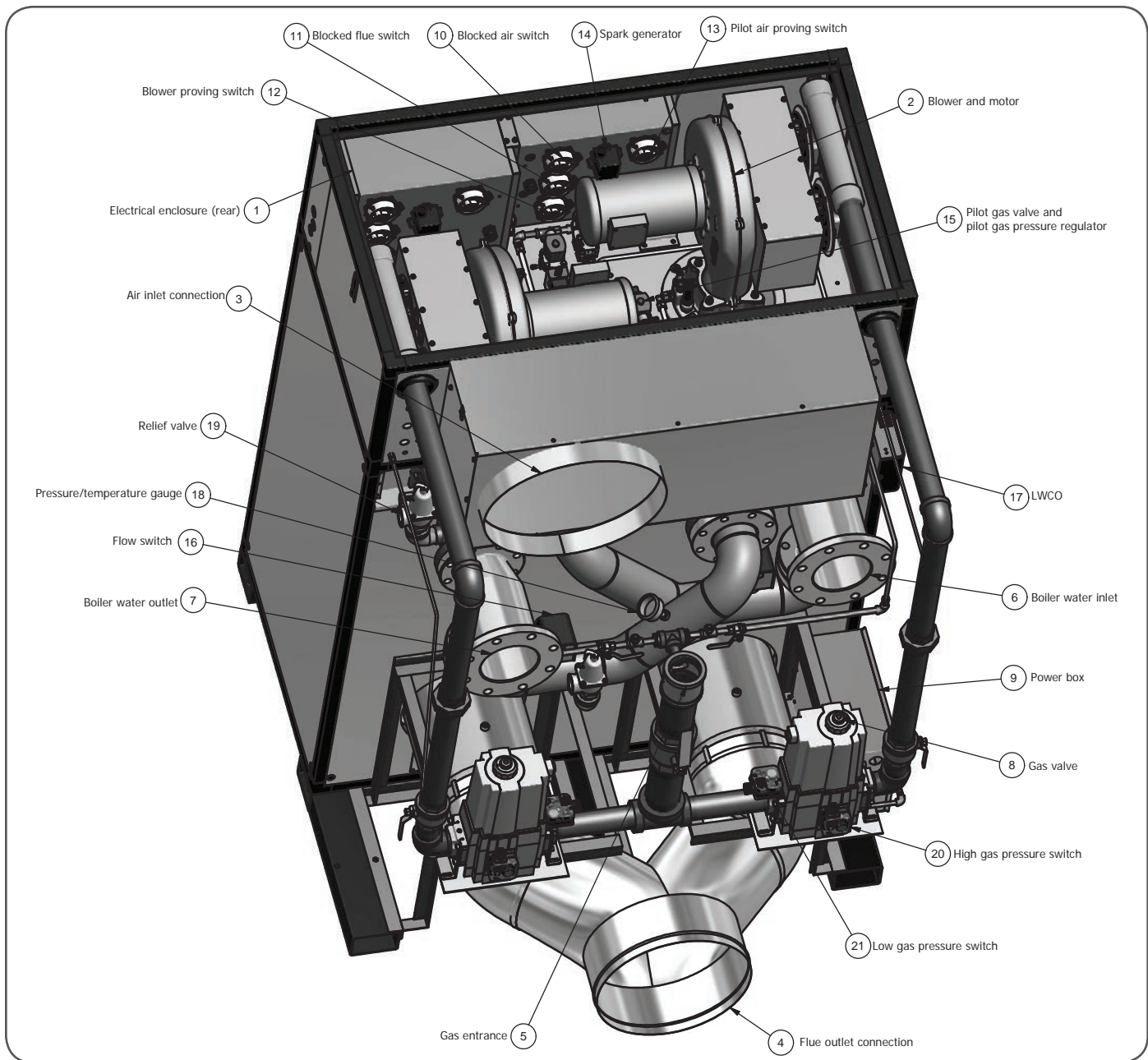

XLF PRIMARY COMPONENTS

- | | |
|-----------------------------------|--|
| 1. Electrical enclosure (rear) | 12. DP switch — blower proving |
| 2. Blower and motor | 13. DP switch — pilot air proving |
| 3. Air inlet connection | 14. Ignitor |
| 4. Flue outlet connection | 15. Pilot gas valve and pilot gas pressure regulator |
| 5. Gas entrance | 16. Flow switch |
| 6. Boiler water return | 17. Low water cutoff |
| 7. Boiler water supply | 18. Pressure/temperature gauge |
| 8. Gas valve | 19. Relief valve |
| 9. Power entrance box | 20. High gas pressure switch |
| 10. DP switch — blocked air inlet | 21. Low gas pressure switch |
| 11. DP switch — blocked flue | |

XLF

Rear view

Air chamber cover removed

See the Futera XLF Control manual for electrical component locations.

| | |
|--|----|
| Before You Start | 3 |
| Ratings & Capacities | 4 |
| Boiler Location | 4 |
| Combustion Air & Ventilation | 4 |
| General Venting Guidelines | 6 |
| Existing Common Vent Systems | 6 |
| Vent System Options | 6 |
| Option1: Direct Vent Positive Pressure — Category IV Horizontal Or Vertical | 7 |
| Approved Stainless Steel Vent Manufacturers | 8 |
| Approved Manufacturers Stainless Boiler Transition Adapters | 9 |
| Option 2: Vertical Venting Positive Pressure, Category IV and Vertical Venting Negative Pressure, Category I & II Figure 5 Or Figure 6 | 13 |
| Option 3: Side Wall Venting Positive Pressure — Category IV Figure 7 | 14 |
| Option 4: Vertical Chimney Venting Negative Pressure — Category I & II (Multiple Boilers With Common Venting) Figure 8 | 15 |
| Category II Chimney Inspection & Sizing | 15 |
| Category II Vent Connections | 15 |
| General Piping Requirements | 17 |
| Heating System Piping | 17 |
| Domestic Water Supply Piping | 22 |
| Temperature Rise Control | 22 |
| Gas Supply Piping | 25 |
| Electrical Wiring | 26 |
| General Operation | 27 |
| Propane Gas | 27 |
| Wiring & Control Set-up | 27 |
| Controls & Interlocks | 27 |
| Sequence Of Operation | 28 |
| Operating Instructions | 29 |
| To Turn Off Gas To Appliance | 31 |
| Checking & Adjustments | 31 |
| Maintenance | 33 |
| Repair Parts | 36 |
| Start-up Report | 41 |

BEFORE YOU START

This manual covers the application, installation, operation and maintenance of a Futera XLF Series finned copper heating boiler.

To obtain the safe, dependable, efficient operation and long life for which this heating boiler was designed, these instructions must be read, understood and followed.

The Futera XLF Series finned copper heating boiler have been design certified by CSA for use with natural and propane gas under the latest revision of ANSI-Z21.13/CSA 4.9, Gas-Fired Hot Water Boilers and CAN 1-3.1, Industrial and Commercial Gas-Fired Packaged Boilers. Each unit has been constructed and hydrostatically tested for a maximum working pressure of **160 psi, 1103 kPa** in accordance with Section IV of the ASME Boiler and Pressure Vessel Code.

All aspects of the boiler installation must conform to the requirements of the authority having jurisdiction, or, in the absence of such requirements, to the National Fuel Gas Code, ANSI Z223.1/ NFPA 54-latest revision. Where required by the authority having jurisdiction, the installation must conform to the Standard for Controls and Safety Devices for Automatically Fired Boilers, ANSI/ ASME CSD-1.

In Canada, the installation must be in accordance with the requirements of CSA B149.1 or .2, Installation Code for Gas Burning Appliances and Equipment.

The owner should maintain a record of all service work performed with the date and a description of the work done. Include the name of the service organization for future reference.

Direct all questions to your RBI distributor or contact the RBI Customer Service Department at:

U.S. —
260 North Elm Street
Westfield, MA 01085

Canada —
7555 Tranmere Drive
Mississauga ONT L5S 1L4

Always include the model and serial numbers from the rating plate of the boiler in question.

RATINGS & CAPACITIES

Before undertaking the installation of the Futera XLF Series boiler check the rating plate to ensure that the unit has been sized properly for the job. The AHRI specify the equivalent amount of direct cast iron radiation that the unit can supply under normal conditions. Also ensure that the unit has been set up for the type of gas available at the installation site. Other important considerations are the availability of an adequate electrical supply, fresh air for combustion and a suitable chimney or vent system.

BOILER LOCATION

1. This boiler is suitable for indoor installation. Locate the boiler in an area that provides good access to the unit. Servicing may require the removal of jacket panels. Allow the minimum clearances between adjacent construction and the boiler as listed in Table 1.

NOTICE Service clearances are not mandatory, but are recommended to ensure ease of service should it be required.

Required Clearances

| From | Clearance to combustible surfaces | | Service clearances | |
|------------|-----------------------------------|-----|--------------------|-----|
| | Inches | mm | Inches | mm |
| Top | 6 | 153 | 36 | 914 |
| Back | 6 | 153 | 24 | 610 |
| Left side | 6 | 153 | 24 | 610 |
| Right side | 6 | 153 | 24 | 610 |
| Front | 6 | 153 | 36 | 914 |

2. An optimum site will be level, central to the piping system, close to a chimney or outside wall and have adequate fresh air for combustion. Ensure that the boiler is level from front to back and from side to side. Use metal shims to level the boiler. Electrical and electronic components must also be protected from exposure to water during operation and maintenance. DO NOT install this boiler in a location that would subject any of the gas ignition components to direct contact with water or excessive moisture during operation or servicing.
3. Ensure that the floor is structurally sound and will support the weight of the boiler.

WARNING The Futera XLF may be installed directly on combustible flooring, but never on carpeting.

4. Locate the boiler in an area that will prevent water damage to adjacent construction should a leak occur or during routine maintenance. If such a location doesn't exist, a suitable drain pan that's adequately drained must be installed under the unit.
5. DO NOT place this boiler in a location that would restrict the introduction of combustion air into the unit or subject it to a negative pressure, see "GENERAL VENTING GUIDELINES".
6. NEVER place this boiler in a location that would subject it to temperatures at or near freezing, see the "FREEZE PROTECTION" section.

WARNING Never store combustible materials, gasoline or any product containing flammable vapors or liquids in the vicinity of the boiler. Failure to comply with this warning can result in an explosion or fire causing extensive property damage, severe personal injury or death!

COMBUSTION AIR & VENTILATION

WARNING This boiler must be supplied with combustion air in accordance with Section 5.3, Air for Combustion & Ventilation, of the latest revision of the National Fuel Gas Code, ANSI Z223.1/NFPA 54 and all applicable local building codes. Canadian installations must comply with CAN/ CGA B149.1 or .2 Installation Code for Gas Burning Appliances and Equipment, or applicable provisions of the local building codes. Failure to provide adequate combustion air for this boiler can result in excessive levels of carbon monoxide which can result in severe personal injury or death!

To operate properly and safely this boiler requires a continuous supply of air for combustion. NEVER store objects on or around the boiler!

CAUTION Combustion air contaminated with fluorocarbons or other halogenated compounds such as cleaning solvents and refrigerants will result in the formation of acids in the combustion chamber. These acids will cause premature failure of the boiler voiding the warranty!

CAUTION If the boiler is operated while the building is under construction it MUST be protected from wood, concrete, sheet rock and other types of dust. Failure to properly protect the unit from construction dust will damage the unit voiding the warranty!

Buildings will require the installation of a fresh air duct or other means of providing make-up air if the intake air option isn't used. Any building utilizing other gas burning appliances, a fireplace, wood stove or any type of exhaust fan must be checked for adequate combustion air when all of these devices are in operation at one time.

Sizing of an outside air duct must be done to meet the requirements of all such devices.

WARNING Never operate the Futera XLF in an environment subjected to a negative pressure unless it is Direct Vented. Failure to comply with this warning can result in excessive levels of carbon monoxide causing severe personal injury or death!

All air from inside the building

If the Futera XLF is to be located in a confined space, the minimum clearances listed in Table 1, must be maintained between it and any combustible construction. When installed in a confined space without the intake air option (as in Figure 5 through Figure 8) two permanent openings communicating with an additional room(s) are required. The combined volume of these

spaces must have sufficient volume to meet the criteria for an unconfined space. The total air requirements of all gas utilization equipment, fireplaces, wood stoves or any type of exhaust fan must be considered when making this determination. Each opening must have a minimum free area of **1 in²/1000 Btu/hr, 2200 mm²/kW** based on the total input rating of ALL gas utilization equipment in the confined area. Each opening must be no less than **100 in², 64,516 mm²** in size. The upper opening must be within **12 in, 305 mm** of, but not less than **3 in, 76 mm** from, the top of the enclosure. The bottom opening must be within **12 in, 305 mm** of, but not less than **3 in, 76 mm** from, the bottom of the enclosure.

All air from outside the building

When installed in a confined space without utilizing the intake air option two permanent openings communicating directly with, or by ducts to, the outdoors or spaces that freely communicate with the outdoors must be present. The upper opening must be within **12 in, 305 mm** of, but not less than **3 in, 76 mm** from, the top of the enclosure. The bottom opening must be within **12 in, 305 mm** of, but not less than **3 in, 76 mm** from, the bottom of the enclosure.

Where directly communicating with the outdoors or communicating with the outdoors through vertical ducts, each opening shall have a minimum free area of **1 in²/4000 Btu/hr, 550 mm²/kW** of the total input rating of all of the equipment in the enclosure.

Where communicating with the outdoors through horizontal ducts, each opening shall have a minimum free area of **1 in²/2000 Btu/hr, 1100 mm²/kW** of the total input rating of all of the equipment in the enclosure.

When ducts are used, they must have the same cross-sectional area as the free area of the opening to which they connect.

When calculating the free area necessary to meet the make-up air requirements of the enclosure, consideration must be given to the blockage effects of louvers, grills and screens. Screens must have a minimum mesh size of **1/4 in, 6.4 mm**. If the free area through a louver or grille is not known, ducts should be sized per Table 2.

Canadian installations must comply with CSA B149.1 when air supply is provided by natural air flow from the outdoors for natural draft, partial fan-assisted, fan-assisted, or power draft-assisted burners, there shall be a permanent air supply opening(s) having a cross-sectional area of not less than **1 in² per 7,000 Btuh, 310 mm² per kW** up to and including 1 million Btuh, plus **1 in² per 14,000 Btuh, 155 mm² per kW** in excess of 1 million Btuh.

Table 2 Make-up Air Louver Sizing

| Input MBH | Required cross-sectional area | | | | | |
|-----------|-------------------------------|-----------------|--------------------------------|-----------------|---------------------------------|-----------------|
| | Wire screen ¼ in (6.4 mm) | | Metal louvers 75% free area | | Wooden louvers 25% free area | |
| | in ² | cm ² | in ² | cm ² | in ² | cm ² |
| 6000 | 1500 | 89676 | 2000 | 12904 | 6000 | 38708 |
| 8000 | 2000 | 12904 | 2668 | 17184 | 8000 | 51616 |
| 10000 | 2500 | 16130 | 3332 | 21496 | 10000 | 64516 |

Intake air option — General guidelines

This configuration provides combustion air directly to the boiler's air intake adapter using a dedicated pipe when using the direct vent option. Combustion air can be drawn in horizontally through the same outside wall which terminates the exhaust gases or vertically through the roof, see Figure 1 through Figure 4.

WARNING Common intake air systems may be used provided the common duct is sized properly. An intake combustion air damper should be installed if the common vent option is used in the intake air pipe of each heater. Improper installation can result in excessive levels of carbon monoxide which can cause severe personal injury or death!

Table 3 Intake Air Pipe Sizing

| Input MBH | Vertical | | Horizontal | |
|-----------|-----------|-----|------------|-----|
| | in | mm | in | mm |
| 6000 | 12 | 305 | 12 | 305 |
| 8000 | 14 | 356 | 14 | 356 |
| 10000 | 18 | 458 | 18 | 458 |

All joints in metal intake air systems must be secured using corrosion resistant fasteners and sealed using a suitable Silicone caulk. If PVC or CPVC is used, the joints must be cleaned with a suitable solvent and connected using a solvent based PVC cement.

CAUTION The combustion air system MUST be supported by the building structure not the boiler.

CAUTION A combustion air damper interlocked with the unit should be installed in the intake air pipe when the infiltration of subfreezing air could occur, otherwise the unit could freeze up voiding the warranty!

Intake air option – Vertical guidelines

The maximum equivalent length for the vertical intake air pipe is **100 ft, 30.5 m**. Each 90° elbow and the intake air terminal are equal to **10 linear ft, 3.0 m** of pipe, see Table 3.

An approved, nonrestrictive intake air terminal must be used. The intake air terminal must terminate as shown in Figure 3. The penetration point in the roof must be properly flashed and sealed.

Intake air option – Horizontal guidelines

The maximum equivalent length for the horizontal intake air pipe is **100 ft, 30.5 m**. Each 90° elbow and the intake air terminal are equal to **10 linear ft, 3.0 m** of pipe. If horizontal runs exceed **5 ft, 1.5 m** they must be supported at **3 ft, 0.9 m** intervals with overhead hangers. The certified intake air terminal from RBI must be used, see Figure 1, Figure 2 and Figure 4.

GENERAL VENTING GUIDELINES

WARNING The vent installation must be in accordance with Part 7, Venting of Equipment, of the National Fuel Gas Code, ANSI Z223.1/NFPA 54—latest revision or applicable provisions of the local building codes. Canadian installations must comply with CAN/CGA B149.1 or .2 Installation Code. Improper venting can result in excessive levels of carbon monoxide which can result in severe personal injury or death!

All vent systems must be fully supported by the building structure and not by the boiler. Appropriate thimbles and fire-stops must be used where required.

WARNING Common vent systems must be properly engineered and sized to provide a negative draft of **0.02 in, 0.5 mm to 0.1 in, 2.5 mm** WC at the flue outlet. Common positive pressure vent systems are not to be used. Improper installation can result in excessive levels of carbon monoxide which can cause severe personal injury or death! Boiler/Water Heater shall not be connected to a chimney flue serving a separate appliance, designed to burn solid fuel.

WARNING Common-vent systems — **It is required that the boiler nearest the vertical chimney be fired first when the horizontal distance exceeds 50% of the vertical distance. Refer to the HeatNet manual on how to select the lead boiler.** Consult the factory if any questions. Improper installation can result in excessive levels of carbon monoxide which can cause severe personal injury or death!

NOTICE For Category II and IV appliances the vent shall not terminate:

- 1) over public walkways; or
- 2) near soffit vents or crawl spaces or other areas where condensate or vapor could create a nuisance or hazard or cause property damage; or
- 3) where condensate vapor could cause damage or could be detrimental to the operation of regulators, relief valves, or other equipment.

EXISTING COMMON VENT SYSTEMS

If an existing boiler is removed from an existing common venting system, the common venting system may then be too large for the proper venting of the remaining appliances connected to it. At the time of removal of an existing boiler, the following steps shall be followed with each appliance remaining connected to the common venting system placed in operation, while the other appliances remaining connected to the common venting system are not in operation.

1. Seal any unused openings in the common venting system.
2. Visually inspect the venting system for proper size and horizontal pitch and determine there is no blockage or restriction, leakage, corrosion and other deficiencies which could cause an unsafe condition.
3. Insofar as is practical, close all building doors and windows and all doors between the space in which the appliances remaining connected to the common venting system are located and other spaces of the building. Turn on clothes dryers and any appliance

not connected to the common venting system. Turn on any exhaust fans, such as range hoods and bathroom exhaust, so they will operate at maximum speed. Do not operate a summer exhaust fan for a boiler installation. Close fireplace dampers.

4. Place in operation the appliance being inspected. Follow the lighting instructions. Adjust thermostat so appliance will operate continuously.
5. Test for spillage at the draft hood relief opening after 5 minutes of main burner operation. Use the flame of a match or candle, or smoke from a cigarette, cigar or pipe.
6. After it has been determined that each appliance remaining connected to the common venting system properly vents when tested as outlined above, return doors, windows, exhaust fans, fireplace dampers and any other gas-burning appliance to their previous condition of use.
7. Any improper operation of the common venting system should be corrected so the installation conforms with the National Fuel Gas Code, ANSI Z223.1/NFPA 54. When resizing any portion of the common venting system, the common venting system should be resized to approach the minimum size as determined using the appropriate Tables in Appendix F in the National Fuel Gas Code, ANSI Z223.1/NFPA 54 and or CAN/CGA B149 Installation Codes.

VENT SYSTEM OPTIONS (CATEGORY I, II, IV)

WARNING Correctly identify the type of vent system the appliance requires before proceeding. Category identification is noted on the unit rating plate.

The flue products in a **Category II and IV** vent system may be cooled below their dew point and form condensate in the flue. The materials used for a **Category II and IV** vent must be resistant to any corrosive damage from flue gas condensate. The flue from a **Category II and IV** vent system must have a condensate drain with provisions to properly collect and dispose of any condensate that may occur in the venting system.

WARNING The maximum equivalent length for the flue outlet vent system for **Category IV** conditions is **100 ft, 30.5 m**. Use Table 4 for the equivalent lengths per fitting. Table 4 - "Category IV Equivalent Length per Fitting" chart is meant as a guideline for preliminary sizing. If vent length approaches 75% of maximum length listed, an engineered vent system calculation must be performed, consult factory.

The Futera XLF may be vented the following ways:

1. **OPTION 1 — Direct Vent, Positive Pressure Category IV (individual venting only)**
Combustion air is piped from the outdoors to the blower inlet. Vent system is certified to UL 1738 for installations in the United States, ULC S636 for installations in Canada.
2. **OPTION 2 — Vertical Vent, Positive Pressure Category IV and Negative Pressure Category I & II (individual venting only)**
Combustion air is obtained from the space in which the unit is installed. Category II & IV vent systems must be certified to UL 1738 for installations in the United States, ULC S636 for installations in Canada. Category I vent systems use an approved metal chimney or masonry chimney.

3. OPTION 3 — Side Wall Vent, Positive Pressure Category IV (individual venting only)

Combustion air is obtained from the space in which the unit is installed. Vent system is certified to UL 1738 for installations in the United States, ULC S636 for installations in Canada. Combustion air is obtained from the space in which the unit is installed.

WARNING To ensure proper boiler operation, boilers that are vented side wall and use room air must not be fired at less than 33% input.

4. OPTION 4 — Vertical Vent, Negative Pressure Category I & II (common venting)

Requires negative pressure in vent (natural draft). Category II venting must be certified to UL 1738 for installations in the United States, ULC S636 for installations in Canada. Category I vent systems use an approved metal chimney or masonry chimney.

WARNING All venting and combustion air material supplied by installer. All venting materials must be approved for the application. Consult the vent manufacturer's product literature.

Table 4 Category IV Equivalent Length Per Fitting

| Model/Outlet Diameter | *K | Equivalent Feet of Straight Pipe | | |
|-----------------------|------|----------------------------------|----------|-----------|
| | | 6000 12" | 8000 14" | 10000 16" |
| Standard Tee | 1.25 | 50 ft | 55 ft | 65 ft |
| Boot Tee | 0.65 | 25 ft | 30 ft | 35 ft |
| Cap - Low Res (UL) | 0.5 | 20 ft | 25 ft | 30 ft |
| 45° w/Bird Screen | 0.4 | 15 ft | 15 ft | 20 ft |
| Elbow - 90° | 0.38 | 15 ft | 20 ft | 25 ft |
| Elbow - 45° | 0.15 | 5 ft | 7 ft | 10 ft |

*Equivalent lengths based on K - factors and (5X) pipe diameters straight length between fittings.

NOTICE The RBI Futera XLF is supplied with a factory installed Z-Flex flue outlet adapter. A manufacturer's supplied stainless steel transition piece must be used when installed with different vent systems. Do not mix vent systems of different manufacturers. Use only listed vent manufacturers (Table 5), terminations (Table 6), and transition adapters (Table 7). The chimney systems manufacturer's installation instructions must be followed.

ANSI Categorization

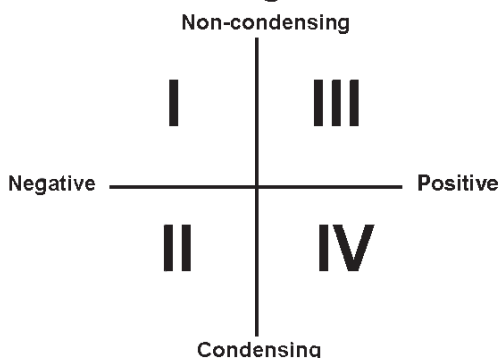

NOTICE Must consult factory when venting single or multiple unit(s) over 100 equivalent feet. Mechanical system may be required.

OPTION 1: DIRECT VENT POSITIVE PRESSURE — CATEGORY IV HORIZONTAL OR VERTICAL

In this configuration the boiler blower is used to push the flue products to the outdoors while drawing combustion air from the outdoors. The Intake Air Option instructions under the "Combustion air & ventilation" section must be followed! The vent system must be sized per Table 4.

Horizontal direct vent systems — Figures 1 & 2

The vent materials used in horizontal vent systems must be certified to UL 1738 for installations in the United States, ULC S636 for installations in Canada. The certified vent terminal from RBI must also be used.

If any part of a single wall metal vent system passes through an unheated space, it must be insulated with insulation rated for **400°F, 204°C**. Structural penetrations must be made using approved fire-stops. For best results, horizontal vent systems should be as short and straight as possible.

The vent system must be both gas tight and water-tight. All seams and joints in metal pipes must be joined and sealed in accordance with the vent system manufacturer's instructions.

When horizontal vent runs exceed **5 ft, 1.5 m** they must be supported at **3 ft, 0.9 m** intervals with overhead hangers. The vent system must be pitched down, toward the vent terminal, **1/4 in/ft, 20 mm/m**. If any part of a single wall metal vent system passes through an unheated space it must be insulated with insulation rated for **400°F, 204°C**.

Horizontal vent systems shall terminate at least **4 ft, 1.2 m** below, **4 ft, 1.2 m** horizontally from or **1 ft, 0.30 m** above any door, window or gravity air inlet into any building.

It must not terminate less than **4 ft, 1.2 m** horizontally from, and in no case above or below, unless a **4 ft, 1.2 m** horizontal distance is maintained, from electric meters, gas meters, regulators and relief equipment; and not less than **7 ft, 2.1 m** above adjacent public walkway.

NOTICE Canadian installations require a minimum of **6 ft, 18.3 m** clearance from electric meters, gas meters, regulators and relief equipment for compliance with CAN B149.1.

The bottom of the vent terminal(s) shall be located at least **5 ft, 1.5 m** above the air intake terminal(s) unless there is a minimum **5 ft, 1.5 m** horizontal separation between them.

Avoid terminal locations likely to be affected by winds, snowdrifts, people and pets. Protect building materials and vegetation from degradation caused by the flue gases.

Table 5 Approved Stainless Steel Vent Manufacturers (CAT II/IV)

| Make | Model |
|--------------------------|---------------|
| DuraVent | FasNSeal Vent |
| M&G DuraVent | DuraSeal Vent |
| Heatfab | Saf-T Vent |
| Metal-Fab | CORR/GUARD |
| Security Chimneys | Secure Seal |
| Schebler Chimney Systems | e Vent |
| VAN-PACKER | CS |
| Z-Flex | Z-Vent |
| Jeremias | GOV |
| ICC | VIC |

Table 6 Approved Intake/Exhaust Terminations (CAT IV - Sidewall/Horizontal Direct Vent)

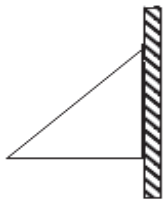
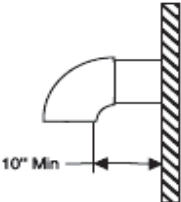
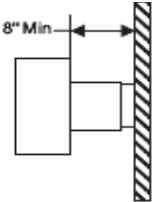
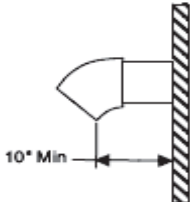
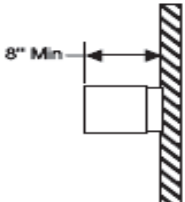
| Exhaust Termination Hood | Exhaust 90 deg | Exhaust Tee | Exhaust 45 deg | Exhaust Straight |
|---|---|---|--|---|
|  |  |  |  |  |

*With bird screen

Table 7 Approved Manufacturers Stainless Steel Boiler Transition Adapters (CAT II/IV)

| Model Size | Z Flex | | M&G DuraVent (DuraSeal) | | ICC | | Metal-Fab | |
|------------|---------------------|--------|----------------------------|-----------|---------------------|------------------|--------------------|------------|
| | Boiler Flue Outlet* | Flue | Transition Adapter | Flue | Transition Adapter | Flue | Transition Adapter | Flue |
| 6000 | A6004899 | Z-Flex | DS12FFNSAU DSD12FFNSAUK | DS DSD | HM-12AC HM-12SDA | VIC-SW VIC-DW | 12FCSLCA | Corr/Guard |
| 8000 | A6004820 | | DS14FFNSAU DSD14FFNSAUK | | HM-14AC HM-14SDA | | 14FCSLCA | |
| 10000 | A6004856 | | DS16FFNSAU DSD16FFNSAUK | | HM-16AC HM-16SDA | | 16FCSLCA | |

| Model Size | Heatfab (Saf-T Vent) | | Security Chimneys (Secure Seal) | | Jeremias | | RBI | |
|------------|----------------------|------------------|---------------------------------|-----------|--------------------|--------------|-----------------|---------------------|
| | Transition Adapter | Flue | Transition Adapter | Flue | Transition Adapter | Flue | Boiler Adapter* | Exhaust Termination |
| 6000 | 91201MAD | EZ/GC CI Plus | SS12FFNSAU SSD12FFNSAUK | SS SSD | SWKL12-S2D – | DWKL SWKL | 09-0602-001 | 09-0116 |
| 8000 | 91401MAD | | SS14FFNSAU SSD14FFNSAUK | | SWKL14-S2D – | | 09-0602-002 | 09-0141 |
| 10000 | 91601MAD | | SS16FFNSAU SSD16FFNSAUK | | SWKL16-S2D – | | 09-0602-003 | N/A |

| Model Size | VAN-PACKER | | DuraVent | | Schebler Chimney Systems (e-Vent) | |
|------------|--------------------|------|---------------------|----------|-----------------------------------|------------|
| | Transition Adapter | Flue | Transition Adapter | Flue | Transition Adapter | Flue |
| 6000 | C12VLSL/M | CS | FSVL612 - 810003467 | FasNSeal | ESW-UNAK-12R EVD-UNAK-12R | ESW EVD |
| 8000 | C14VLSL/M | | FSVL614 - 810003508 | | ESW-UNAK-14R EVD-UNAK-14R | |
| 10000 | C16VLSL/M | | FSVL616 - 810003543 | | ESW-UNAK-16R EVD-UNAK-16R | |

*Factory Installed

NOTICE The RBI Futera XLF is supplied with a factory installed Z-Flex flue outlet adapter. A manufacturers supplied stainless steel transition piece must be used when installed with different vent systems. Do not mix vent systems of different manufacturers. Use only listed vent manufacturers (Table 5), terminations (Table 6), and transition adapters (Table 7). The chimney systems manufacturer's installation instructions must be followed.

Vertical direct vent systems — Figure 3

If any part of a single wall metal vent system passes through an unheated space, it must be insulated with insulation rated for **400°F, 204°C**. Structural penetrations must be made using approved fire-stops.

An approved, nonrestrictive vent terminal must be used. The top of a vertical vent system must extend at least **5.5 ft, 1.7 m** above the roof surface and maximum snow line that it passes through, **4 ft, 1.2 m** above the intake air terminal, see Figure 3.

In addition the vent system must conform to the dimensions shown in Figure 3. The penetration point in the roof must be properly flashed and sealed.

The vent system must be gas tight. All seams and joints in metal pipes must be joined and sealed in accordance with the vent system manufacturer's instructions.

Combination direct vent systems — Figure 4

The boiler can be vented vertically with the intake air piped horizontally through an outside wall. Follow the instructions in the Intake Air Option — Horizontal Guidelines. Also follow the general instructions in the “Combustion Air & Ventilation” and “General Venting Guidelines” sections.

Figure 1 VENT OPTION 1: DIRECT VENT — Horizontal Air Intake and Venting for a Single Direct Vent System (CATEGORY IV)

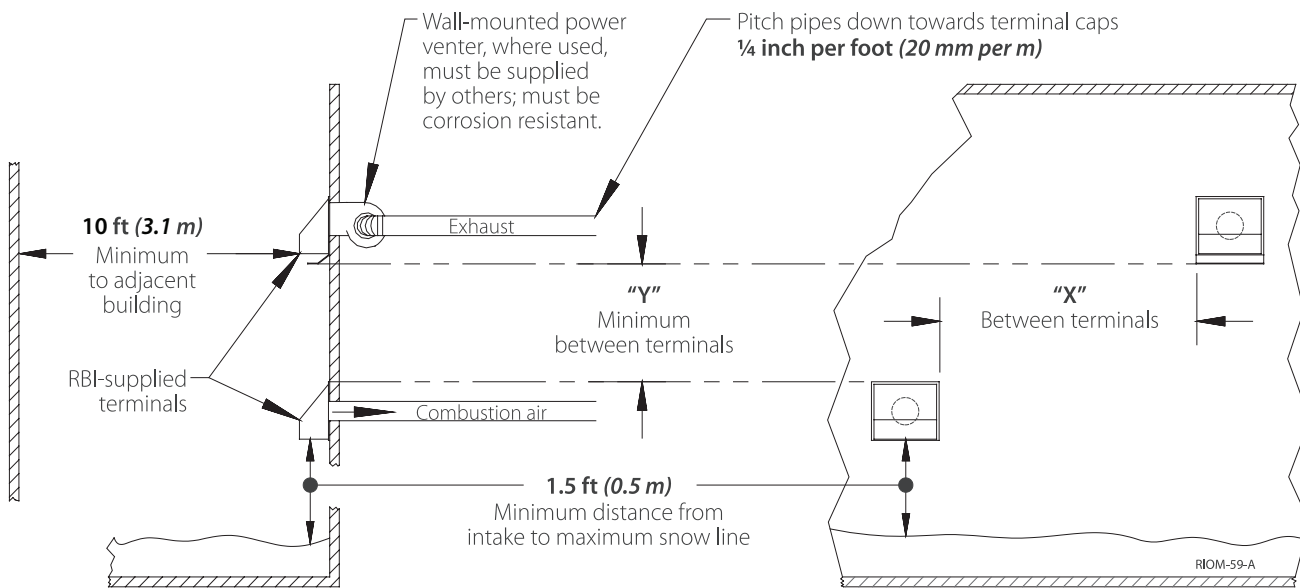

WARNING When running horizontal combustion air and venting for single or multiple units, exhaust and combustion air terminals must be installed on the same plane (outside wall) in order to prevent pressure differences due to prevailing winds. In cold climates, double-wall or insulated inlet pipe is recommended to prevent condensation.

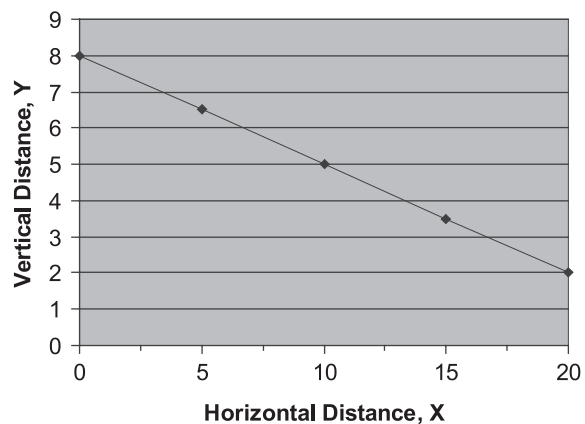

Figure 2 VENT OPTION 1: DIRECT VENT — Horizontal Air Intake and Venting for Multiple Direct Vent Systems (CATEGORY IV)

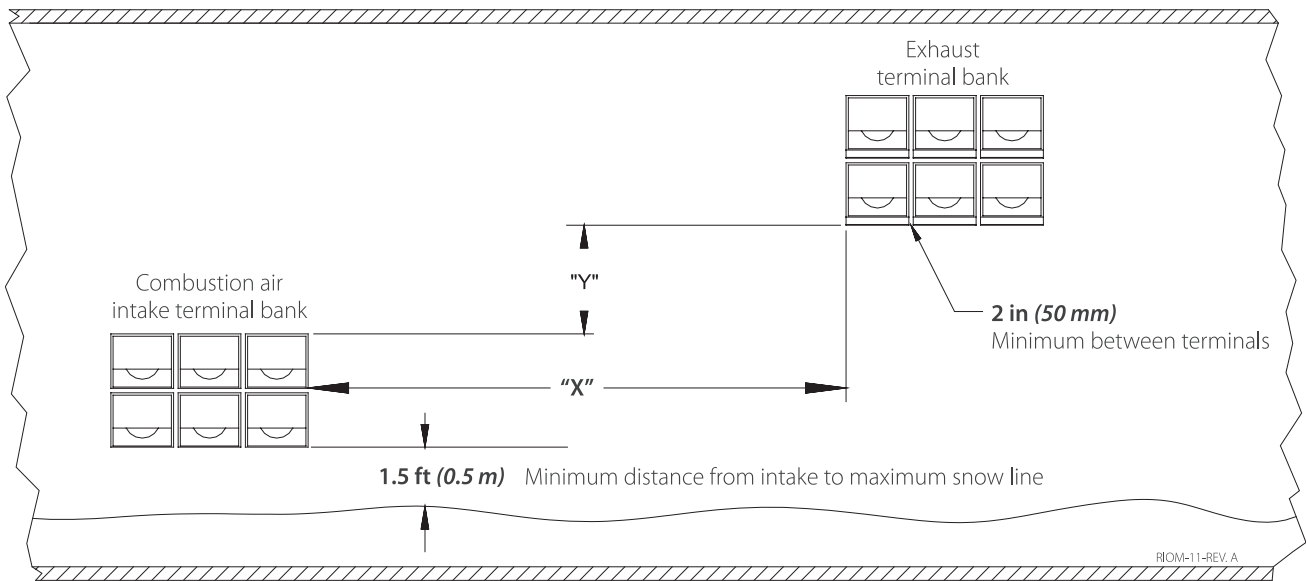

Figure 3 VENT OPTION 1: DIRECT VENT — Combination Direct Vent System (CATEGORY IV)

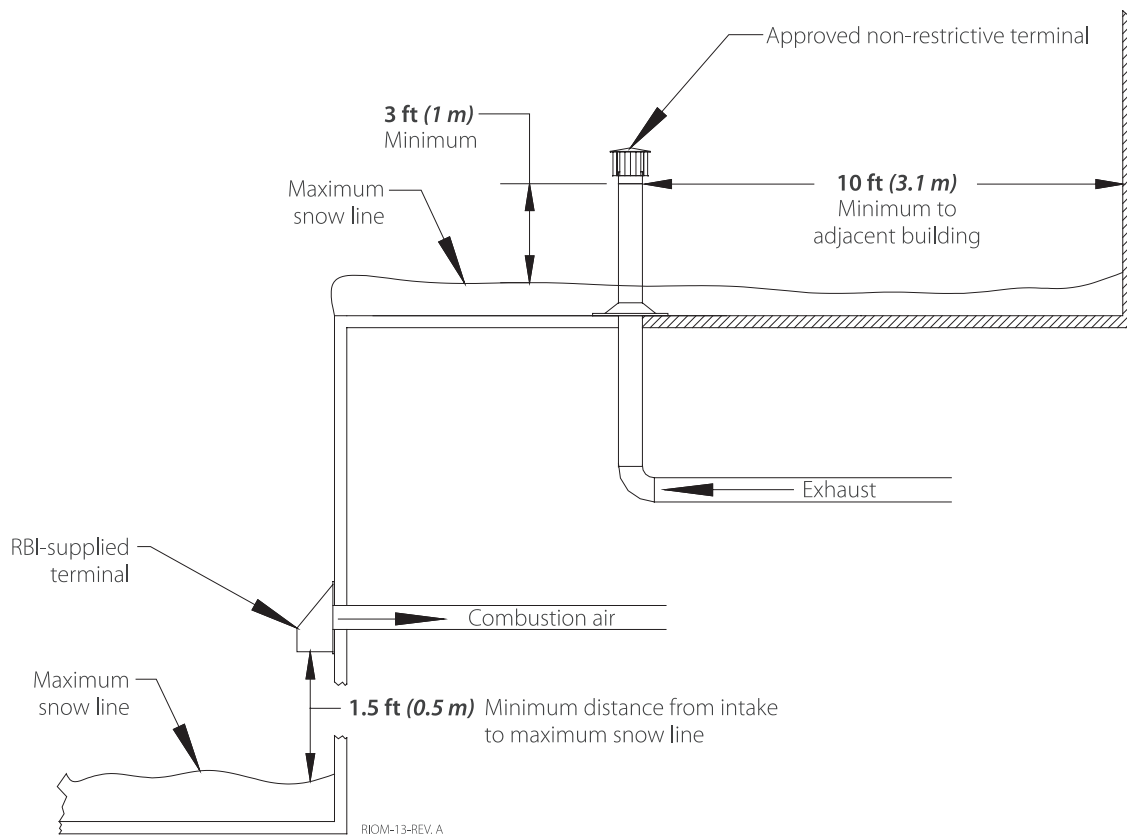
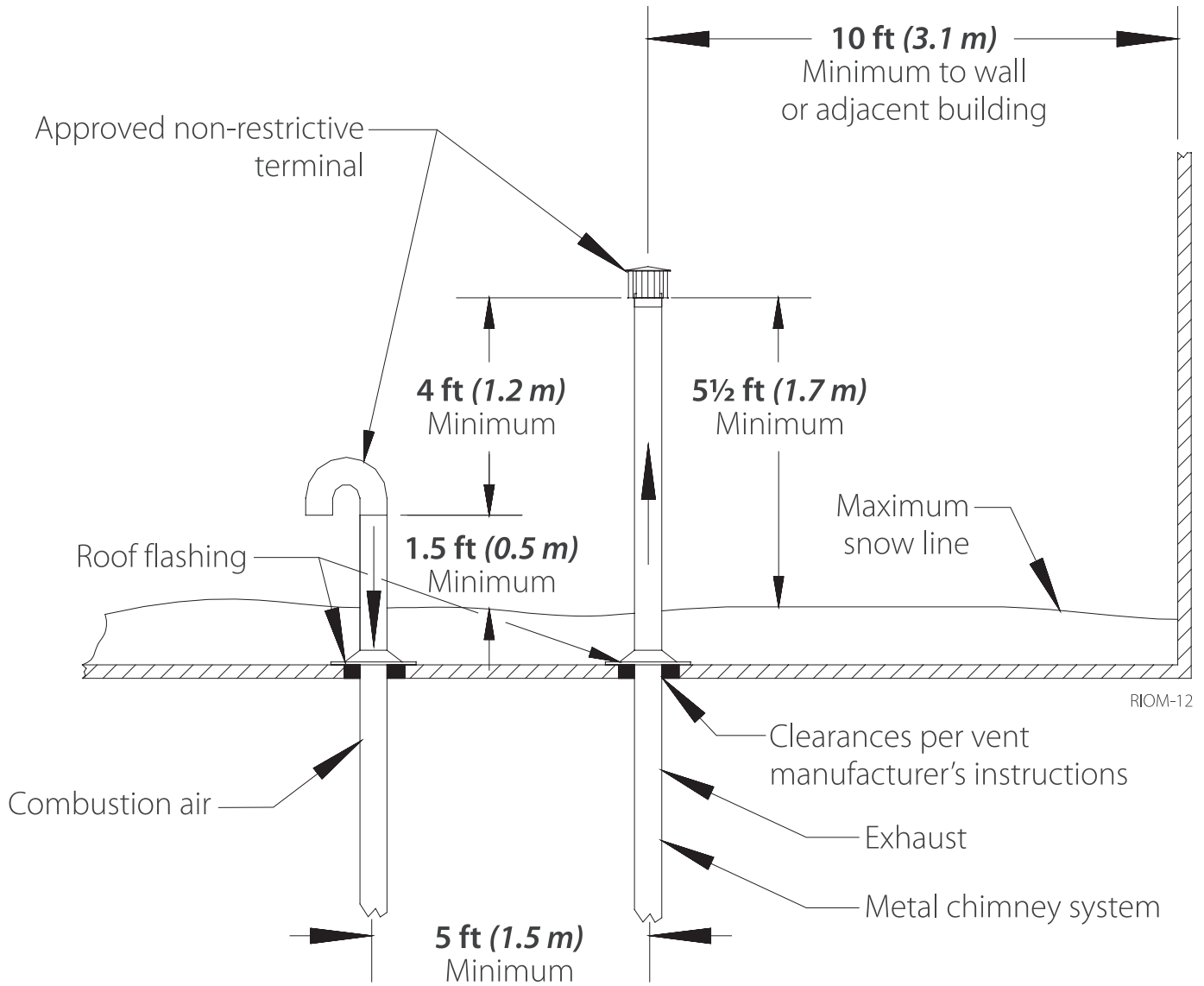

Figure 4 VENT OPTION 1: DIRECT VENT — Vertical Air Intake and Venting for Direct Vent System (CATEGORY IV)



WARNING

Locate exhaust terminal downwind from air intake to reduce potential for flue gas recirculation. Failure to comply could result in severe personal injury or death.

OPTION 2: VERTICAL VENTING POSITIVE PRESSURE (CATEGORY IV), NEGATIVE PRESSURE (CATEGORY I & II) FIGURE 5 & FIGURE 6

WARNING Masonry chimneys, when used, must be lined with a metal liner certified for Category II & IV venting.

WARNING Correctly identify the type of vent system the appliance requires before proceeding. Category identification is noted on the unit rating label.

A thorough inspection of the masonry chimney must be performed to ensure that the chimney is clean, properly constructed, lined and sized. Exterior masonry chimneys should not be used unless

properly lined to prevent condensation and draft problems. When applied as Category I or II see Table 8 & 8a for vent diameters. When applied as Category IV see Table 4 for minimum vent diameters. The Futera XLF when listed as a Category I or II appliance and vented vertically into a listed metal chimney system, must provide a negative pressure not greater than 0.01 to 0.10 in, 0.25 to 2.5mm WC at the boiler flue collar with the unit running. A barometric damper must be installed between the flue collar and vent connector when negative pressures exceed 0.10 in, 2.5 mm WC.

Figure 5 VENT OPTION 2: VERTICAL CHIMNEY VENTING
Vertical Venting — with a listed metal chimney system

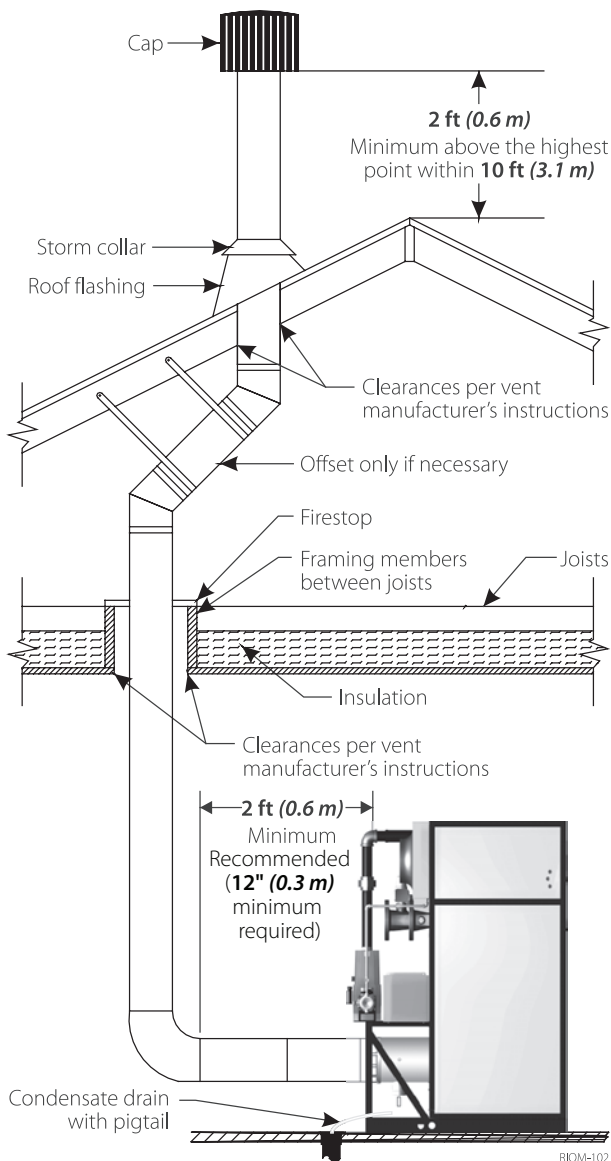
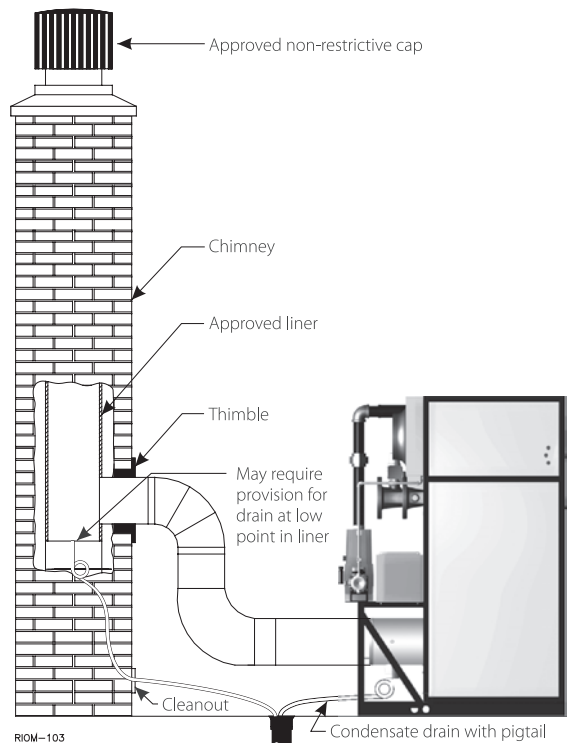

Figure 6 VENT OPTION 2: VERTICAL CHIMNEY VENTING
Vertical Venting — using a lined masonry chimney



OPTION 3: SIDE WALL VENTING POSITIVE PRESSURE —CATEGORY IV FIGURE 7

In this configuration the boiler blower is used to push the flue products horizontally to the outdoors, see Figure 7. The air for combustion is taken from the space in which the unit is installed. The applicable instructions under the

“Combustion Air & Ventilation” section must be followed! The vent guidelines under the Horizontal Direct Vent Systems section must also be followed.

WARNING To ensure proper boiler operation, boilers that are vented side wall and use room air must not be fired at less than 33% input.

Figure 7 VENT OPTION 3: SIDE WALL VENT — Side Wall Venting

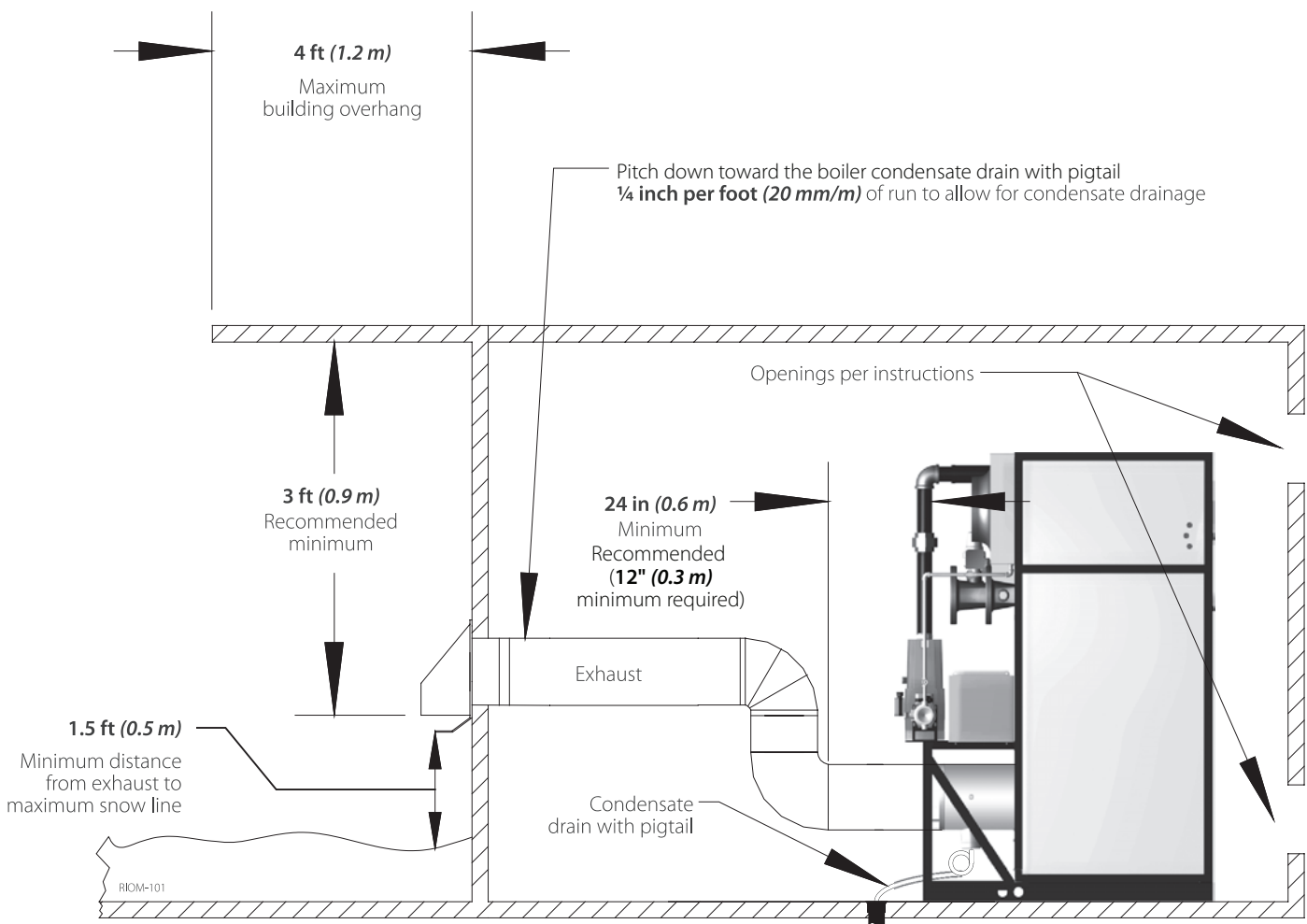

OPTION 4: VERTICAL CHIMNEY VENTING NEGATIVE PRESSURE — CATEGORY I & II (MULTIPLE BOILERS WITH COMMON VENTING) FIGURE 8

WARNING Common vent systems cannot be pressurized.

The Futera XLF is listed as a Category I or II appliance when vented vertically into a listed metal chimney system. See Figure 8 (multiple boilers). The chimney must provide a negative pressure not greater than **0.10 in, 2.5 mm WC** at the boiler flue collar with the unit running.

NOTICE When using a listed metal chimney system the chimney system manufacturer's instructions must be followed.

WARNING Masonry chimneys, when used with Category II appliances, must be lined with a metal liner certified to UL 1738 for installations in the United States and ULC S636 for installations in Canada.

WARNING The vent piping must be large enough to safely vent the combined output of all of the appliances connected to the system.

If an appliance using any type of a mechanical draft system operating under positive pressure is connected to a chimney flue, never connect any other appliances to this flue. Doing so can result in excessive levels of carbon monoxide which can cause severe personal injury or death!

WARNING Correctly identify the type of vent system the appliance requires before proceeding. Category identification is noted on the unit rating label.

Table 8a Equivalent Breaching & Chimney Size, Negative Pressure (Category I)

| Input — MBH | in | mm |
|---|-----------|-----|
| 6000 | 12 | 305 |
| 8000 | 14 | 356 |
| 10000 | 16 | 406 |
| Note: These sizes are based on a 20 ft, 6.1m chimney height. | | |

CHIMNEY INSPECTION & SIZING — CATEGORY I & II

A thorough inspection of the masonry chimney must be performed to ensure that the chimney is clean, properly constructed, lined and sized. Exterior masonry chimneys should not be used unless properly lined to prevent draft problems.

Table 8 & 8a lists the minimum riser sizes required for the XLF boiler.

Table 8 Equivalent Breaching & Chimney Size, Negative Pressure (Category II)

| Input — MBH | in | mm |
|---|-----------|-----|
| 6000 | 12 | 305 |
| 8000 | 14 | 356 |
| 10000 | 16 | 406 |
| Note: These sizes are based on a 20 ft, 6.1m chimney height. | | |

WARNING Correctly identify the type of vent system the appliance requires before proceeding. Category identification is noted on the unit rating label.

VENT CONNECTIONS

Locate the boiler as close to the chimney as possible. Use the shortest, straightest vent connector possible for the installation. If horizontal runs exceed **5 ft, 1.5 m** they must be supported at **3 ft, 0.9 m** intervals with overhead hangers.

The boiler vent connectors should be sloped up toward the breaching at a minimum rate of **¼ in per ft, 21 mm per m**. On masonry chimneys the connector must terminate flush with the inside of the chimney liner (as shown in Figure 6).

Always provide a minimum clearance of **6 in, 152 mm** between single wall vent pipe and any combustible materials.

WARNING Failure to maintain minimum clearances between vent connectors and any combustible material can result in a fire causing extensive property damage, severe personal injury or death!

Exit cones are favorable when used to increase the velocity of the flue gas exiting the stack and, may also help, in cold climates, to reduce ice build-up. Exit cone terminations must be supplied by others, installed per manufacturer's instructions, and meet local and federal code.

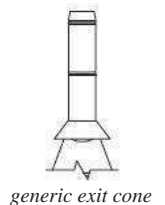
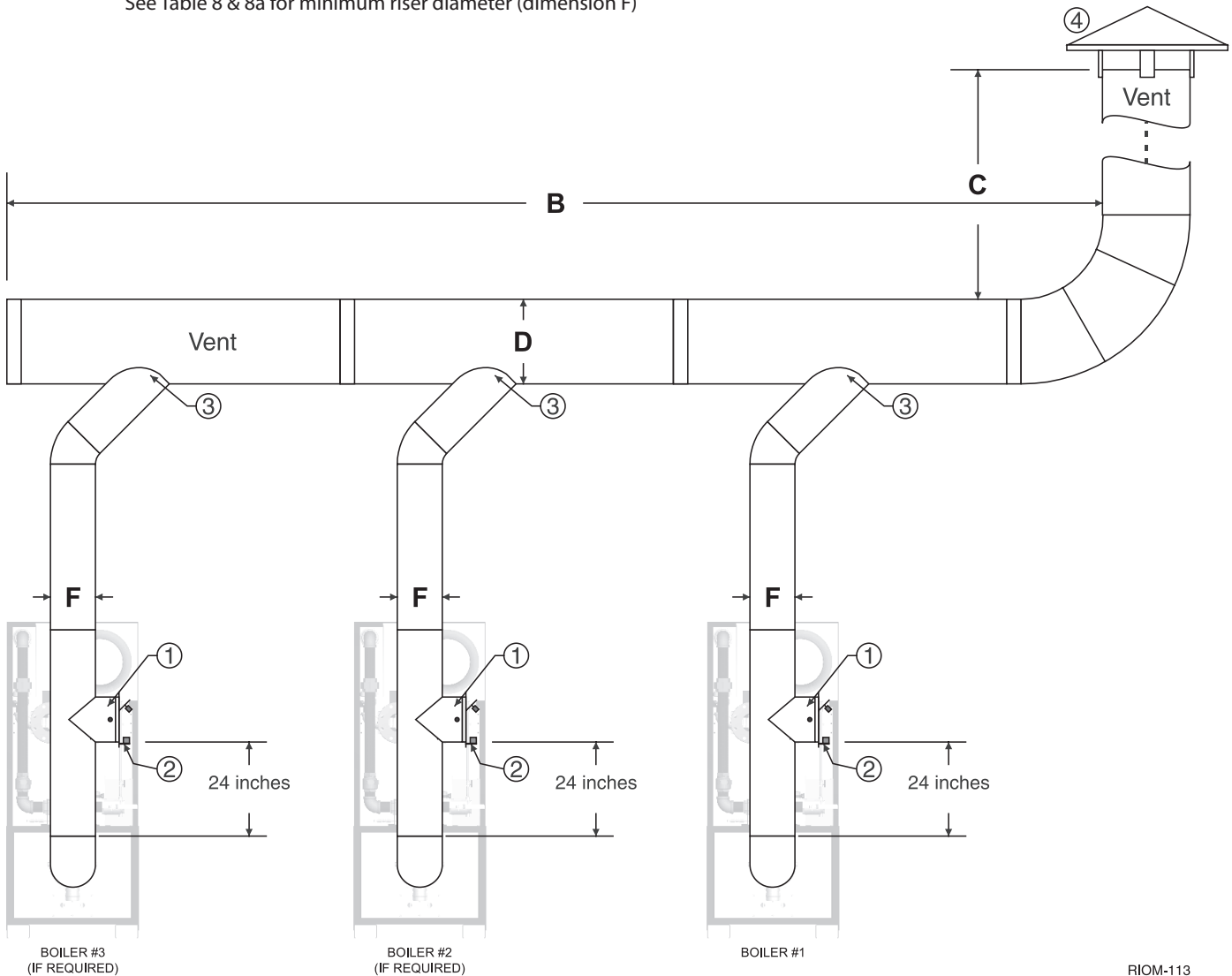

Figure 8 OPTION 4: VERTICAL CHIMNEY VENTING — Vertical Venting — Multiple-Boiler Installations
See Table 8 & 8a for minimum riser diameter (dimension F)



RIOM-113

Legend for Figure 8

WARNING It is recommended that the boiler nearest the vertical chimney must always be fired first when the horizontal exceeds 50% of the vertical. Refer to the HeatNet manual on how to select the lead boiler.

A negative pressure of **0.02 to 0.10 in wc** is required in each boiler's riser when all boilers are operating at full input.

Provide clearance from the boiler of no less than **6 in** to combustible surfaces or **24 in** for service.

1. A barometric damper must be installed on the riser of each boiler, **24 in** above the vent elbow. [Exception: If the vent system is designed using accepted engineering practices, and the design calculations prove there is no need for barometric dampers, the barometric dampers may be omitted.] When required by applicable codes, install a thermal spill switch on each barometric damper.

2. Install a thermal spill switch on each barometric damper (when required by applicable codes).
3. Connect each boiler riser to the common vent with a Y connection or Boot T.
4. Install an approved vent cap at the vent termination.
5. DIMENSIONS:
B - breeching length
C - chimney height
D - breeching diameter
F - riser diameter (no smaller than the dimension given in Table 8 & 8a)
6. Size the chimney and breeching per local codes and vent pipe manufacturer's recommendations, using generally accepted engineering practices.

Note: Consult factory for vertical heights beyond 100 ft.

WARNING Correctly identify the type of vent system the appliance requires before proceeding. Category identification is noted on the unit rating plate.

GENERAL PIPING REQUIREMENTS

CAUTION Improper piping of this boiler will void the manufacturer's warranty and can cause boiler failure resulting in flooding and extensive property damage! Excessive water hardness causing scaling in the copper heat exchanger tubes is NOT covered under the manufacturer's warranty. See Table 11. Excessive pitting and erosion of the internal surface of the copper heat exchanger tubes is NOT covered under the manufacturer's warranty if the result of high water flow rates. See Table 10. Return water temperatures below **140°F, 60°C** will result in heat exchanger damage from excessive condensation voiding the manufacturer's warranty, see Primary/Secondary Piping. See Figure 9.

NOTICE Shut off valves and unions should be installed at the inlet and outlet connections of the boiler to provide for isolation of the unit should servicing be necessary.

Freeze protection

Installations in areas where the danger of freezing exists are not recommended unless proper freeze protection is provided. The following precautions **MUST** be observed:

1. A continuous flow of water through the unit **MUST** be maintained! The pump responsible for flow through the boiler must run continuously!
2. A polypropylene glycol/water mixture suitable for the minimum temperature that the unit will be exposed to must be used. The pump must be capable of producing a minimum of 15% more flow and overcoming a 20% increase in head loss. Domestic water systems must be isolated from the boiler by the use of a heat exchanger or other approved method.
3. If the unit must be shut off for any reason the electric, gas and water supplies **MUST** be shut off and the unit and its pump completely drained.

Relief valve

Pipe the discharge of the pressure relief valve as shown in Figure 9.

WARNING Never install any type of valve between the boiler and the relief valve or an explosion causing extensive property damage, severe personal injury or death may occur!

Flow Switch

The flow switch supplied with the boiler must be wired to the terminal strip in the control panel to prevent the boiler from firing unless there's adequate water flow through the unit. The flow switch must be installed in the supply piping adjacent to the boiler outlet connection.

CAUTION Failure to properly install the flow switch may result in damage to the boiler heat exchanger voiding the warranty!

HEATING SYSTEM PIPING

General piping requirements

All heating system piping must be installed by a qualified technician in accordance with the latest revision of the ANSI/ASME Boiler and Pressure Vessel Code, Section IV, and ANSI/ASME CSD-1, Standard for Controls and Safety Devices for Automatically Fired Boilers. All applicable local codes and ordinances must also be followed. A minimum clearance of **1 in, 25 mm** must be maintained between heating system pipes and all combustible construction. All heating system piping must be supported by suitable hangers not the boiler. The thermal expansion of the system must be considered when supporting the system. A minimum system pressure of **12 psig, 82.7 kPa** must be maintained.

Heating boiler piping connections

The supply and return connections should be sized to suit the system, per Table 9.

Table 9 Supply & Return Connections

| Input MBH | Supply size | Return size |
|-------------|-------------|-------------|
| 6000 | 4" FLANGE | 4" FLANGE |
| 8000/10000* | 6" FLANGE | 6" FLANGE |

*Supply/Return piping must be a minimum of 6" diameter

Pump requirements

This low mass boiler requires a continuous minimum water flow for proper operation. The boiler pump must be sized to overcome the head loss of the boiler and the near-boiler piping in order to achieve the required temperature rise. Table 10 provides the heat exchanger pressure drop and temperature rise figures. The temperature rise across the boiler must never exceed **35°F, 19.4°C**. The adjustable pump delay turns the pump on each time the burner fires and runs the pump for 20 to 600 seconds after the call for heat is satisfied.

WARNING A temperature rise outside of the range listed in Table 10 will result in damage to the heat exchanger, voiding the warranty! The maximum allowable temperature rise through the boiler is **35°F, 19.4°C**.

WARNING The maximum allowable flow rate through a Futera XLF boiler is **520 GPM, 32.8 L/s** when equipped with copper tubes. A cupronickel heat exchanger allows for **630 GPM, 39.7 L/s**.

Figure 9 Futera XLF Piping

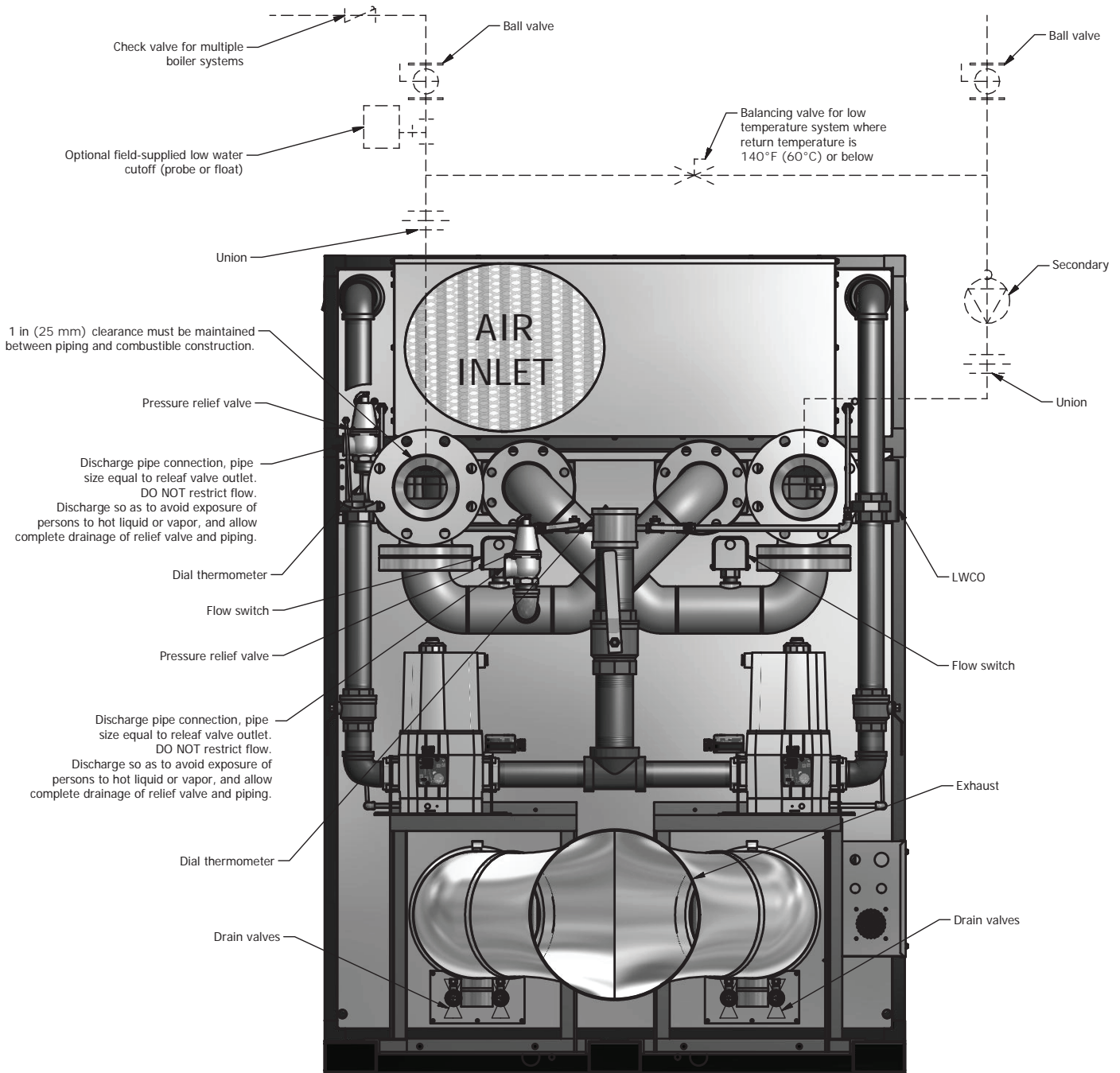

Table 10 Temperature Rise Table

| Model Number | $\Delta T = 20^{\circ}\text{F}$ | | $\Delta T = 11.1^{\circ}\text{C}$ | |
|--------------|---------------------------------|-------------|-----------------------------------|------------|
| | Flow Rate | Pres. Drop | Flow Rate | Pres. Drop |
| | GPM | Ft | <i>L/s</i> | <i>kPa</i> |
| 6000 | 524.6 | 13.2 | 33.1 | 39.6 |
| 8000 | NA | NA | NA | NA |
| 10000 | NA | NA | NA | NA |
| Model Number | $\Delta T = 25^{\circ}\text{F}$ | | $\Delta T = 13.9^{\circ}\text{C}$ | |
| | Flow Rate | Pres. Drop | Flow Rate | Pres. Drop |
| | GPM | Ft | <i>L/s</i> | <i>kPa</i> |
| 6000 | 419.7 | 8.5 | 26.5 | 25.3 |
| 8000 | 546.1* | 28.6 | 34.5* | 85.6 |
| 10000 | NA | NA | NA | NA |
| Model Number | $\Delta T = 30^{\circ}\text{F}$ | | $\Delta T = 16.7^{\circ}\text{C}$ | |
| | Flow Rate | Pres. Drop | Flow Rate | Pres. Drop |
| | GPM | Ft | <i>L/s</i> | <i>kPa</i> |
| 6000 | 349.7 | 5.9 | 22.1 | 17.6 |
| 8000 | 455.1 | 19.9 | 28.7 | 59.5 |
| 10000** | 567.6 | 33.0 | 35.8 | 98.7 |
| Model Number | $\Delta T = 35^{\circ}\text{F}$ | | $\Delta T = 19.4^{\circ}\text{C}$ | |
| | Flow Rate | Pres. Drop | Flow Rate | Pres. Drop |
| | GPM | Ft | <i>L/s</i> | <i>kPa</i> |
| 6000 | 299.8 | 4.3 | 18.9 | 12.9 |
| 8000 | 390.1 | 14.6 | 24.6 | 43.7 |
| 10000** | 486.5 | 24.3 | 30.7 | 72.5 |

* This flow rate exceeds the recommended maximum for a boiler with a standard copper heat exchanger. Use a greater temperature rise or consult manufacturer. Consider a cupro-nickel heat exchanger, because its maximum flow rate is **630 GPM**.

** Cupronickel standard on Model 10000 only.

Low water cutoff

If a boiler is installed above any radiation elements it must be fitted with a low water cutoff device.

Refer to the wiring diagram supplied with the boiler for proper wiring connections.

Expansion tank and air separator

An expansion tank or other means to control thermal expansion must be installed in the heating system. An expansion tank must be installed close to the boiler on the suction side of the pump. An air scoop and automatic air vent must also be installed to eliminate air trapped in the system.

Primary/secondary piping

Boilers connected to heating systems using zone valves, zone pumps, or systems that have excessive flow rates or return water temperatures less than **140°F**, **60°C** must be isolated from these systems to protect the boiler.

Variable water flows

Figure 10, shows a typical primary/secondary piping system. A dedicated pump is used to maintain a constant water flow through the boiler. This boiler pump is sized to overcome the head loss of the boiler and near-boiler piping system while supplying the flow rate required to maintain the desired temperature rise across the boiler heat exchanger. The system pump is sized to provide the required flow to the heating system. The boiler piping connections to the heating system piping must be a maximum 6 pipe diameters between centers to ensure zero pressure drop in the primary system.

Low return water temperatures

To prevent the problems associated with condensation of the products of combustion due to low return water temperatures a primary/secondary piping system with a bypass and bypass valve must be installed, see Figure 11. The bypass system must be sized the same as the secondary piping. The primary and secondary pumps should be sized to provide the required flow through each system. The boiler piping connections to the heating system piping must be a maximum 6 pipe diameters between centers to ensure zero pressure drop in the primary system.

Multiple boiler systems

Systems using multiple boilers can also be installed using a primary/secondary manifold system, Figure 13.

Piping for use with cooling units

The boiler, when used in connection with a refrigeration system, must be installed so the chilled medium is piped in parallel with the boiler. Appropriate valves must be used to prevent the chilled water from entering the boiler.

When a boiler is connected to a heating coil that may be exposed to refrigerated air from an air handling device, the piping system must be equipped with flow-control valves or some other automatic means of preventing gravity circulation of the boiler water during the cooling cycle.

Figure 10 Typical Primary/Secondary Piping System (See Notes)

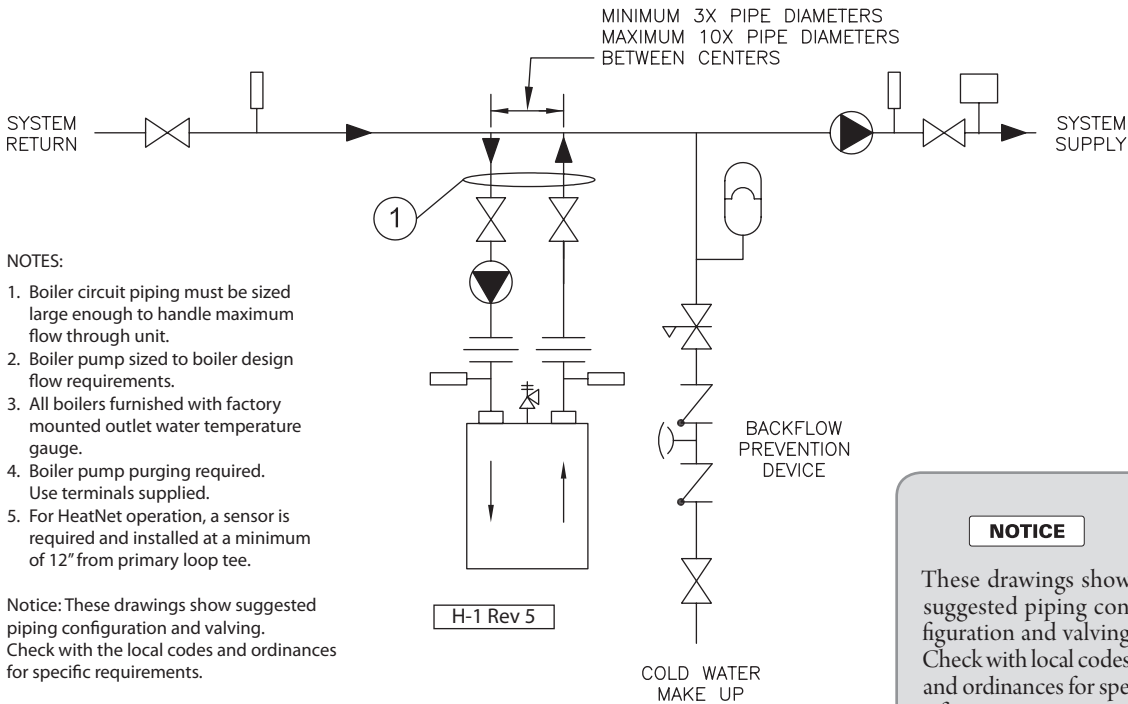

NOTES:

1. Boiler circuit piping must be sized large enough to handle maximum flow through unit.
2. Boiler pump sized to boiler design flow requirements.
3. All boilers furnished with factory mounted outlet water temperature gauge.
4. Boiler pump purging required. Use terminals supplied.
5. For HeatNet operation, a sensor is required and installed at a minimum of 12" from primary loop tee.

Notice: These drawings show suggested piping configuration and valving. Check with the local codes and ordinances for specific requirements.

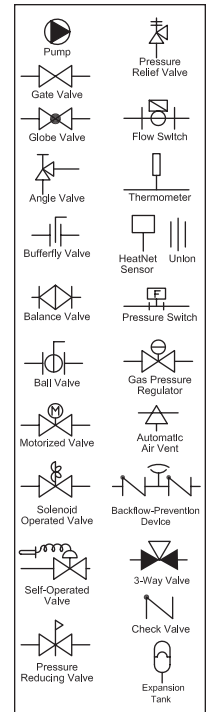
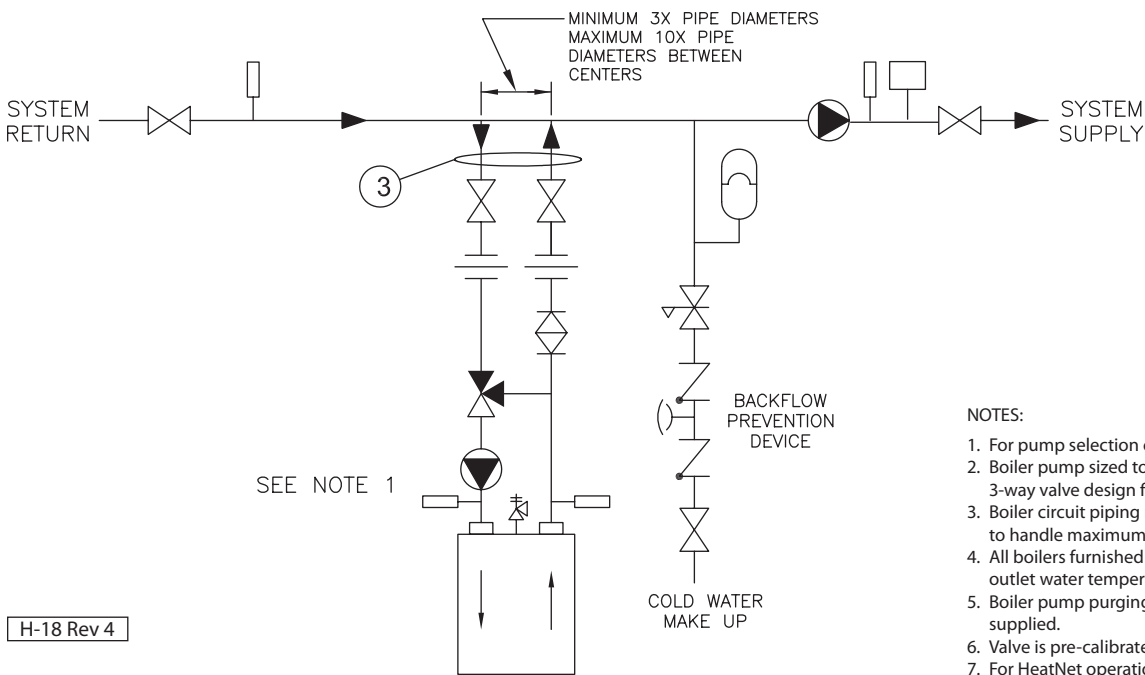

Figure 11 Low Temperature Piping with Thermostatic Valve (See Notes and Adjustment Procedure)



NOTES:

1. For pump selection consult factory.
2. Boiler pump sized to boiler and thermostatic 3-way valve design flow requirements.
3. Boiler circuit piping must be sized large enough to handle maximum flow through unit.
4. All boilers furnished with factory mounted outlet water temperature gauge.
5. Boiler pump purging required. Use terminals supplied.
6. Valve is pre-calibrated for 140°F return temperature.
7. For HeatNet operation a sensor is required and installed at a minimum of 12" from primary loop tee. supplied.

Notice: These drawings show suggested piping configuration and valving. Check with the local codes and ordinances for specific requirements.

Figure 13 Multiple Boiler Piping (See notes)

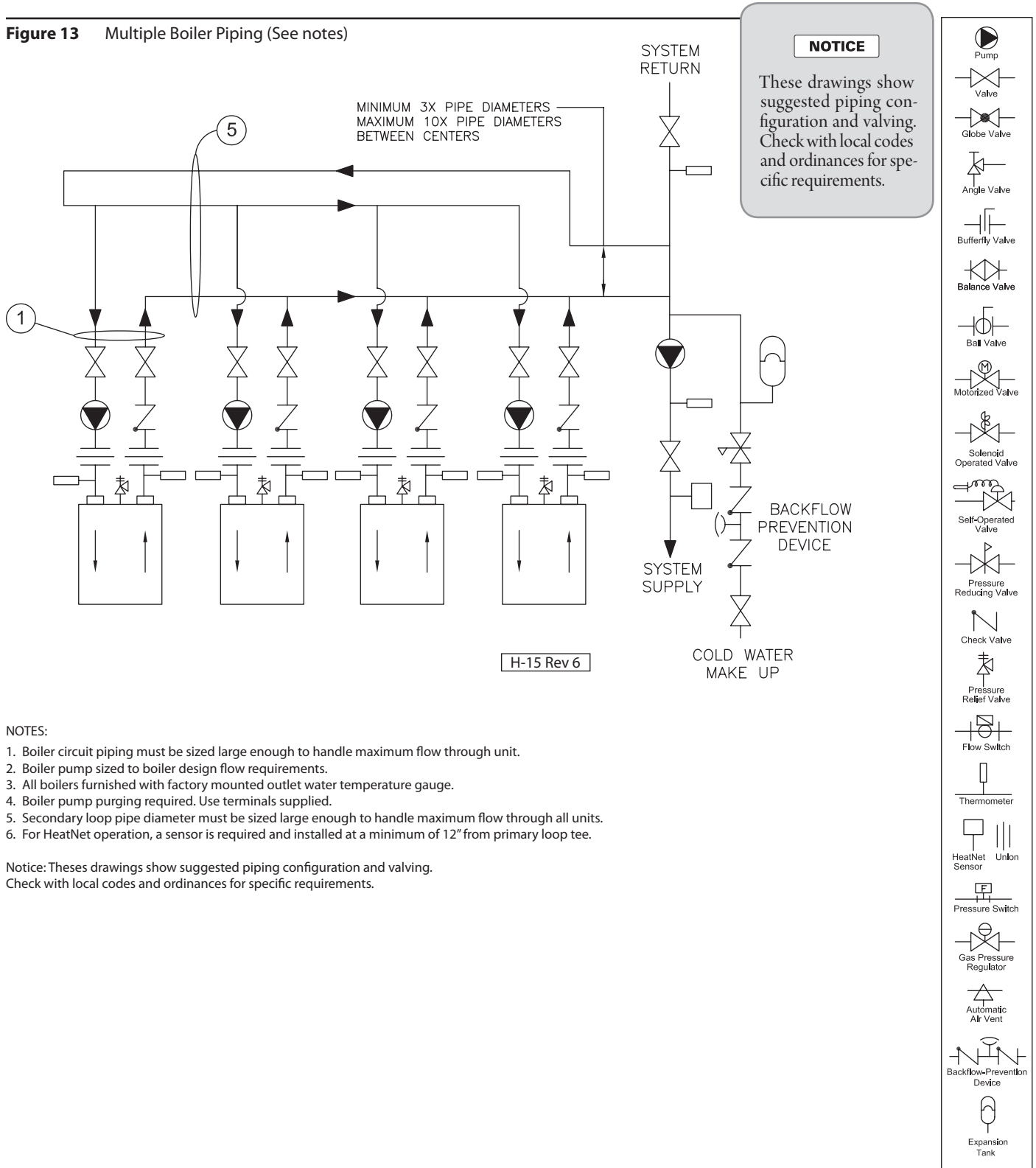

NOTES:

1. Boiler circuit piping must be sized large enough to handle maximum flow through unit.
2. Boiler pump sized to boiler design flow requirements.
3. All boilers furnished with factory mounted outlet water temperature gauge.
4. Boiler pump purging required. Use terminals supplied.
5. Secondary loop pipe diameter must be sized large enough to handle maximum flow through all units.
6. For HeatNet operation, a sensor is required and installed at a minimum of 12" from primary loop tee.

Notice: These drawings show suggested piping configuration and valving. Check with local codes and ordinances for specific requirements.

DOMESTIC WATER SUPPLY PIPING

CAUTION Proper controls must be used to prevent water supplied for domestic use from exceeding **130°F, 54°C** or a scald injury will occur! When higher water temperatures are required for appliances such as a dishwasher, a mixing valve or some other tempering means must be installed. Households with small children may require water temperatures less than **120°F, 49°C**. Local codes must be complied with!

General piping requirements

The Futera XLF can be used in combination with an indirect tank to provide hot water for domestic use. Piping and components must be suitable for use with potable water. The indirect storage tank must be equipped with a temperature and pressure relief valve that complies with ANSI Z21.22 or CAN-4.4 and CAN-4.6.

NOTICE The indirect storage tank must be located as close to the boiler as possible to prevent excessive head loss which will reduce flow.

Water chemistry

The required temperature rise across the boiler is based on water having a hardness between 8 and 18 grains per gallon with a level of dissolved solids not exceeding 350 ppm. Water having a hardness less than 8 grains can cause excessive corrosion of the heat exchanger. Water that has a hardness greater than 18 grains per gallon and/or a level of dissolved solids exceeding 350 ppm will require a recalculation of the pump size and temperature rise.

A cupronickel heat exchanger may also be required. The manufacturer should be consulted when these water conditions are encountered. See Table 11.

CAUTION The maximum allowable flow rate through a Futera XLF boiler is **520 GPM, 32.8 L/s** when equipped with copper tubes. The cupronickel heat exchanger allows for **630 GPM, 39.7 L/s**. See Table 10.

RBI boilers are designed to run scale free. Due to the extreme variables of water conditions world wide it is necessary to consider pH values and water hardness in relationship to scaling. It is crucial to consider these two variables when making heat exchanger and pump selections. If local water conditions are extreme, follow the guidelines in the Heat Exchanger Selection Table (Table 11) and the Pumping Performance Table (Table 10). Scale free operation can be achieved by using water with a hardness between 8 and 18 and by maintaining the pH between 5 and 9. Follow the conditions listed under NORMAL in the table. In some areas of the country additional precautions must be observed due to unusual characteristics of the local water supply. Call the nearest RBI representative for details.

TEMPERATURE RISE CONTROL

WARNING Water returned to the boiler inlet must not be less than **140°F, 60°C** or excessive condensation of the products of combustion will damage the boiler, voiding the warranty. The method outlined below can be employed to prevent this condition from occurring.

A balancing valve should be installed on the outlet side of the boiler for purposes of adjusting the flow rate through the heat exchanger. HeatNet sensors are installed on both the inlet and outlet of the boiler for determining the temperature rise through the unit.

The proper velocity through the boiler must be maintained in accordance with Table 10, for efficient operation and long life. If the temperature rise through the boiler is lower than recommended the water velocity is too high. Premature erosion of the heat exchanger will occur. Conversely, if the temperature rise is higher than recommended in Table 10, the flow rate is too low. Scaling and softening of the heat exchanger will occur.

Thermostatic Mixing Valve – Water Above **140°F, 60°C** Water can be stored at temperatures above **140°F, 60°C** provided that a thermostatically controlled mixing valve is used to temper the hot water to an acceptable temperature before it's supplied for domestic use.

The mixing valve **MUST** be set to prevent a scald injury from occurring, see the caution against scalding.

Storage of water for domestic use above **140°F, 60°C** will provide an increased quantity of tempered water and help prevent the growth of water born bacteria.

To properly size the pump a grain hardness and pH test must be taken at the installation site before the order is placed. Proper pump sizing will improve heater performance and help ensure heater longevity.

Expansion Tank

An expansion tank or other means to control thermal expansion must be installed in the water heating system if back flow prevention devices are installed.

Pump Requirements

This low-mass boiler requires a continuous minimum water flow for proper operation. The low water flow switch provided for this unit will shut down the boiler if flow falls below the required minimum level. Table 10 provides the heat exchanger pressure drop chart and temperature rise table. The temperature rise across the boiler must never exceed **35°F, 19.4°C**.

Two typical water heating systems are shown in Figures 14 and 15.

Table 11 Futera XLF Heat Exchanger Selection

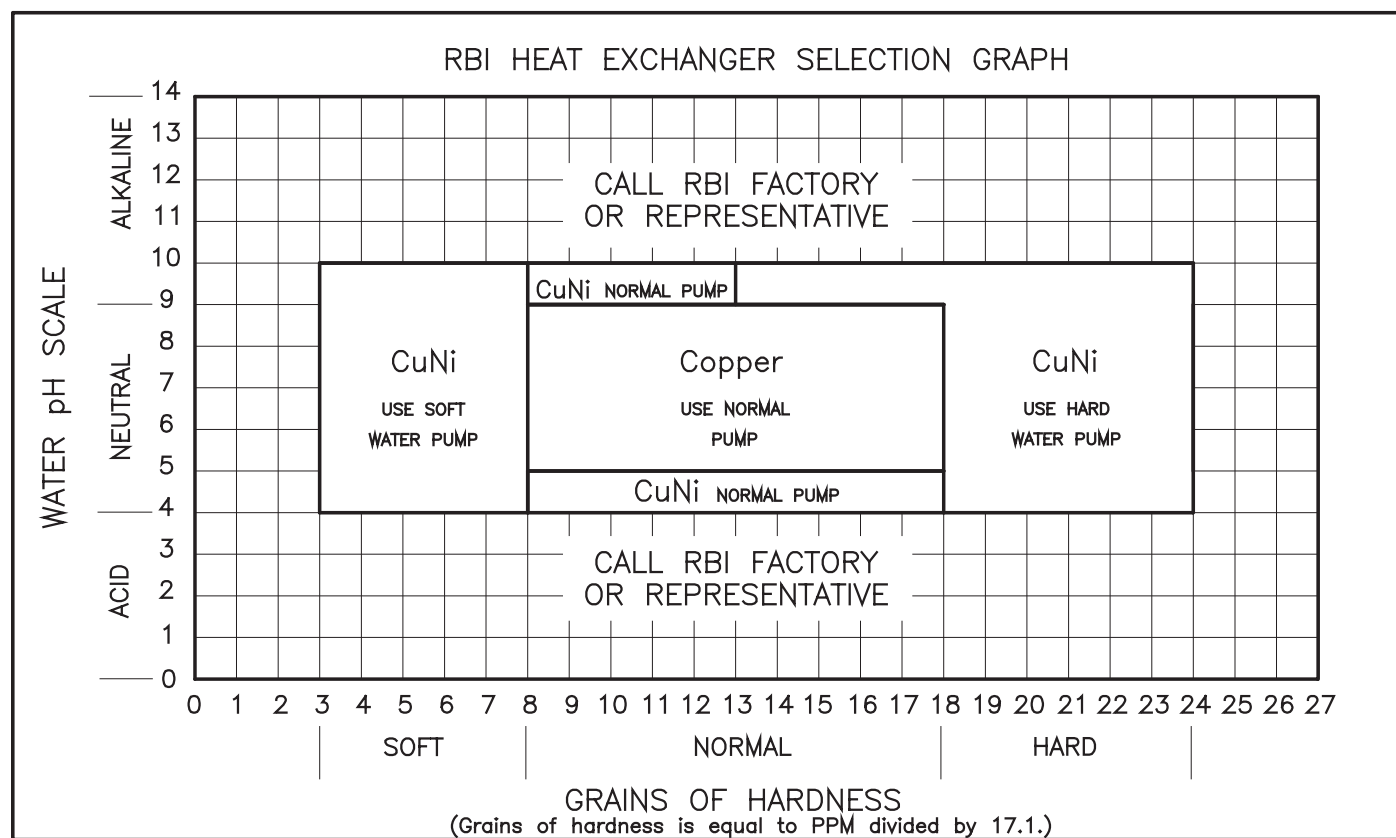

Copyright Pending, MESTEK 12/03

Figure 14 Typical Single Boiler with Indirect Storage Tank Piping

NOTES:

1. Locate HeatNet sensor with well in lower 1/3 of tank. Install sensor with heat sensing compound.
2. Thermal expansion tank may be required, check local codes.
3. Hot water tanks should be equipped with a combination temperature & pressure relief valve. Valve shall discharge to a safe place with an air gap. Refer to local codes.
5. MA Code requires an 1/8 in hole in check valve to compensate for thermal expansion.
6. Contractor shall verify, with authority having jurisdiction, for the requirements of an acid neutralization kit.
7. A thermostatic mixing valve may be required at the outlet of the tank in order to limit the mixed water to a desirable temperature helping to prevent scalding and injury. Consult local codes.

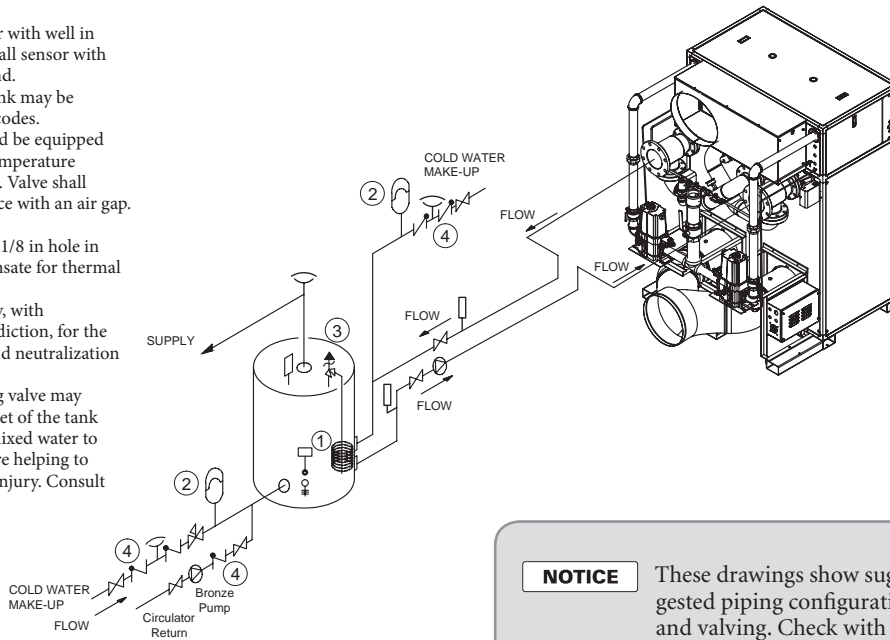

LEGEND:

| | |
|-------------|-----|
| Boiler Loop | ——— |
| Supply Loop | ——— |

| | |
|--|--|
| | |
| | |
| | |
| | |
| | |
| | |
| | |
| | |
| | |
| | |
| | |

NOTICE These drawings show suggested piping configuration and valving. Check with local codes and ordinances for specific requirements.

Figure 15 Typical Multiple Boiler with Indirect Storage Tank Piping

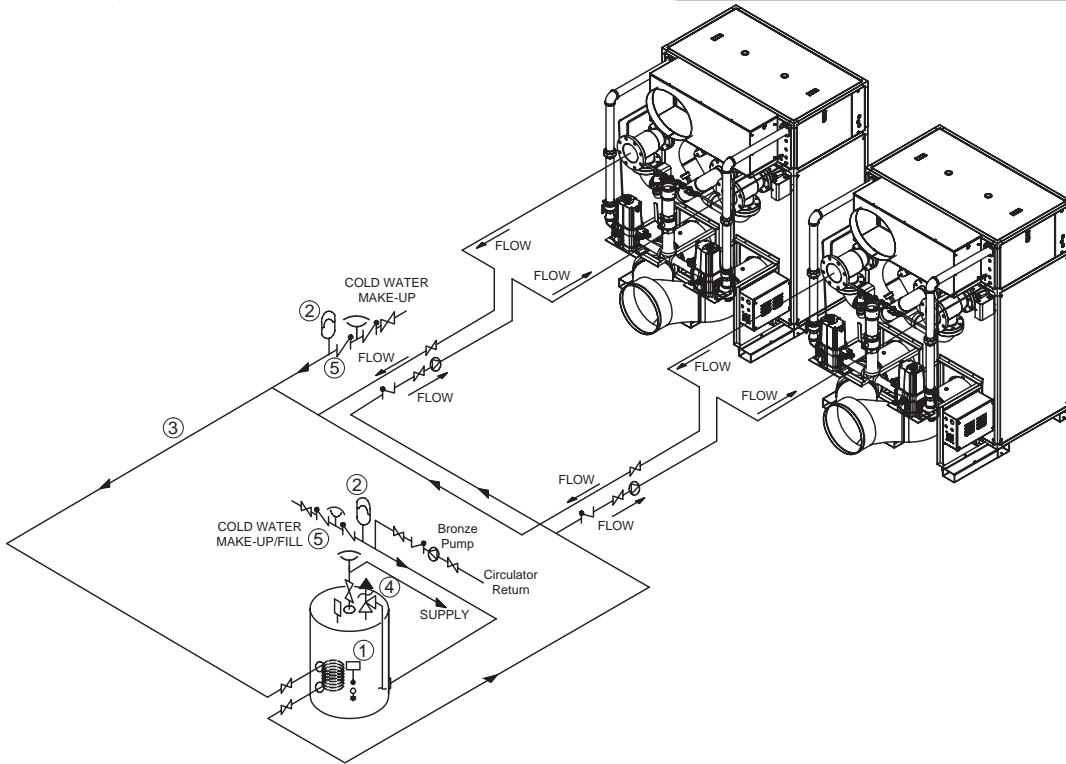

NOTES:

1. Locate HeatNet sensor with well in lower 1/3 of tank. Install sensor with heat sensing compound.
2. Thermal expansion tank may be required, check local codes.
3. Common piping must be sized for maximum combined heater flow.
4. Hot water tanks should be equipped with a combination temperature & pressure relief valve. Valve shall discharge to a safe place with an air gap. Refer to local codes.
5. MA Code requires an 1/8 in hole in check valve to compensate for thermal expansion.
6. Contractor shall verify, with authority having jurisdiction, for the requirements of an acid neutralization kit.
7. A thermostatic mixing valve may be required at the outlet of the tank in order to limit the mixed water to a desirable temperature helping to prevent scalding and injury. Consult local codes.

Notice: These drawings show suggested piping configuration and valving. Check with local codes and ordinances for specific requirements.

GAS SUPPLY PIPING

WARNING Check the boiler rating plate to make sure that the boiler is for the type of gas that will be used. If it isn't, do not connect the boiler to the gas supply. Gas supply piping must be in accordance with the National Fuel Code, ANSI Z223.1-latest revision or applicable provisions of the local building codes. Canadian installations must comply with CAN/CGA B149.1 or B149.2 Installation Code. Failure to comply with this warning can result in extensive property damage, severe personal injury or death!

The Futera XLF comes from the factory ready to be piped to the gas supply. If for any reason the boiler is not for the type of gas available at the installation site, call your RBI representative to resolve the problem.

NOTICE With all units operating the gas supply pressure (natural gas) at the safety shutoff valve inlet must be:
 Minimum **3.5 in, 88.9 mm, WC**
 Maximum **14 in, 356 mm, WC**
 Gas pressure not to exceed a maximum of a (1.0 in WC) drop when firing from minimum input to full load of the gas supply line and all the appliances running.

Tables 12 and 13 should be used to ensure that the gas supply piping is sized properly. If more than one appliance is supplied by the same supply pipe, the piping must be sized based on the maximum possible demand. Do not neglect the pressure drop due to pipe fittings. Table 12 should be used in conjunction with Table 13 to ensure that the gas supply piping has the capacity to meet the demand.

Figure 16 depicts the proper way to connect the boiler to the gas supply piping. The manual shut-off valve **MUST** be installed in the supply piping. It should be installed **5 ft, 1.5 m** above the floor where required by local codes. Provide a sediment trap at the bottom of the vertical section of the gas supply pipe upstream of the gas controls.

Figure 16 Gas Supply Piping

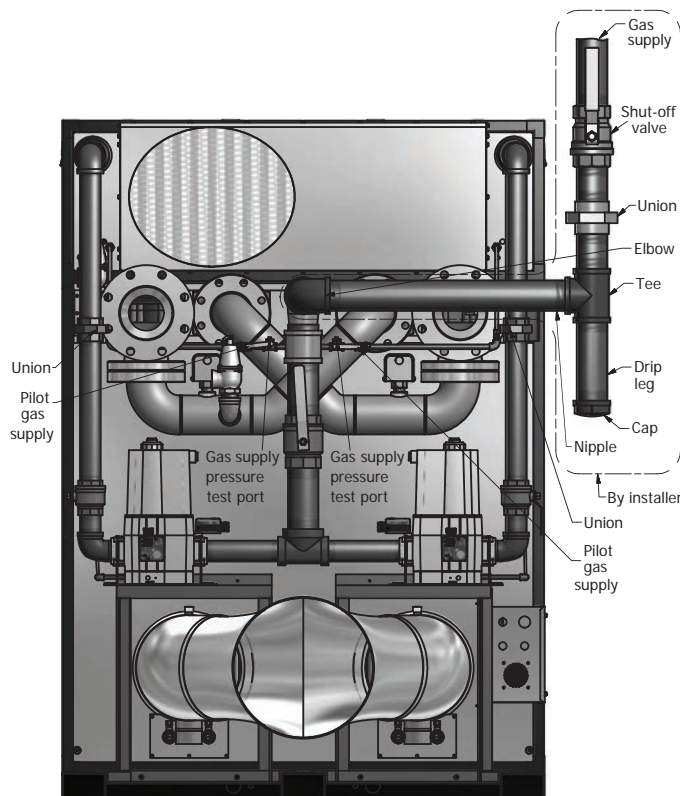

Table 12 Gas Pipe Capacities (Natural Gas)

| Maximum pipe capacity in ft ³ /hr, based on 0.60 specific gravity natural gas at a pressure of 0.5 psig or less and a 0.3" WC pressure drop, for iron pipe with nominal size below, and for total equivalent length (in feet): | | | | | | | | | | | | | | | |
|---|--------|--------|--------|--------|--------|--------|--------|--------|--------|--------|--------|--------|--------|--------|-------|
| Pipe size | 10 | 20 | 30 | 40 | 50 | 60 | 70 | 80 | 90 | 100 | 125 | 150 | 175 | 200 | 250 |
| 2" | 3,050 | 2,100 | 1,650 | 1,450 | 1,270 | 1,150 | 1,060 | 990 | 928 | 870 | 777 | 710 | 648 | 602 | 534 |
| 2½" | 4,800 | 3,300 | 2,700 | 2,300 | 2,000 | 1,850 | 1,690 | 1,600 | 1,480 | 1,400 | 1,240 | 1,130 | 1,030 | 960 | 851 |
| 3" | 8,500 | 5,900 | 4,700 | 4,100 | 3,600 | 3,250 | 3,000 | 2,800 | 2,610 | 2,500 | 2,190 | 2,000 | 1,820 | 1,700 | 1,500 |
| 4" | 17,500 | 12,000 | 9,700 | 8,300 | 7,400 | 6,800 | 6,110 | 5,800 | 5,330 | 5,100 | 4,460 | 4,100 | 3,720 | 3,460 | 3,070 |
| 5" | 31,700 | 21,800 | 17,500 | 15,000 | 13,300 | 12,000 | 11,100 | 10,300 | 9,650 | 9,110 | 8,090 | 7,320 | 6,730 | 6,260 | 5,550 |
| 6" | 51,300 | 35,300 | 28,300 | 24,200 | 21,500 | 19,500 | 17,900 | 16,700 | 15,600 | 14,800 | 13,100 | 11,900 | 10,900 | 10,100 | 8,990 |

Note: For propane piping — Multiply the gas volume capacities above by 0.62 for propane flow capacities in ft³/hr. Multiply the propane flow capacity by 2500 Btu/ft³ to determine the propane Btu/hr capacity for a given pipe size and length.

Table 13 Equivalent Length (feet) for Typical Fittings

| Pipe size | Fitting or valve | | | |
|-----------|------------------|-------------------|------------|----------|
| | 90° elbow | Tee (branch flow) | Gate valve | Gas cock |
| 2" | 5.2 | 10.3 | 1.2 | 3.0 |
| 2½" | 6.2 | 12.3 | 1.4 | 3.5 |
| 3" | 7.7 | 15.3 | 1.8 | 4.5 |
| 4" | 10.1 | 20.2 | 2.4 | 6.0 |
| 5" | 12.6 | 25.2 | 2.9 | 7.3 |
| 6" | 15.2 | 30.4 | 3.5 | 13.4 |

Equivalent lengths above are for threaded fittings. Multiply values above by 0.75 for flanged fittings.

A ground joint union should be installed between the boiler gas controls and the supply piping. Each of these items are needed to ensure long life and ease of servicing. Always use a pipe sealant that is suitable for use with LP gas.

CAUTION Always use a wrench on the gas valve body when making gas connections to it. Never over-tighten the piping entering the gas valve body or gas valve failure may result!

When applicable, provisions for vent, bleed and gas relief lines must be made in accordance with the latest revision of ANSI Z223.1/NFPA 54. The main Dungs gas valve supplied with boiler does not require external venting.

Safe lighting and other performance criteria were met with the gas manifold and control assembly provided on the boiler. All gas connections **MUST** be leak tested before putting the boiler into operation.

WARNING Never use an open flame to test for gas leaks. Always use an approved leak detection method. Failure to comply with this warning can cause extensive property damage, severe personal injury or death!

Whenever the gas supply piping is pressure tested the boiler gas controls must be protected. If the test pressure is equal to, or less than **1/2 psig, 3.5 kPa** isolate the boiler by closing its manual shut off valve, see Figure 16. If the test pressure is greater than, or equal to **1/2 psig, 3.5 kPa**, disconnect the boiler and its individual shut-off valve.

ELECTRICAL WIRING

Electrical Power Connections

CAUTION Label all wires prior to disconnection when servicing controls. Wiring errors can cause improper and dangerous operation! Verify proper operation after servicing.

CAUTION Au moment de l'entretien des commandes, étiquetez tous les fils avant de les débrancher. Des erreurs de câblage peuvent entraîner un fonctionnement inadéquat et dangereux. S'assurer que l'appareil fonctionne adéquatement une fois l'entretien terminé.

The electrical connections to this boiler must be made in accordance with all applicable local codes and the latest revision of the National Electrical Code, ANSI/NFPA-70. Installation should also conform with CSA C22.1 Canadian Electrical Code Part I if installed in Canada.

A properly rated shut-off switch should be located at the boiler. The boiler must be grounded in accordance with the authority having jurisdiction, or if none, the latest revision of the National Electrical Code, ANSI/NFPA-70.

Line voltage field wiring of any controls or other devices must conform to the temperature limitation of type TEW wire at **95°F, 35°C** above room temperature. Use copper conductors with a minimum size of #14 awg. The wire size must be compatible with the total amp draw of the circuit.

Refer to the wiring diagram supplied with the boiler for proper wiring connections and boiler full load amperage (FLA).

GENERAL OPERATION

WARNING Before proceeding read and fully understand the instructions contained in this manual. Do not attempt to operate this boiler if it has not been installed in accordance with the guidelines set forth in this manual. Failure to comply with this warning can result in extensive property damage, severe personal injury or death!

Should overheating occur or the gas supply fail to shut off, turn off the manual gas control valve to the appliance. Do not interrupt water flow through the boiler.

Hydronic heating boilers

Open the make-up water valve and slowly fill the boiler and all of the radiation with water. Ensure that all bleed and drain valves are closed.

Adjust the make-up water pressure regulator so a minimum **12 psig, 82.7 kPa** system pressure is maintained at the highest point in the system piping. If a make-up water pump is used adjust it to maintain a minimum **12 psig, 82.7 kPa** system pressure.

Open the system bleed and drain valves, one at a time, to purge the air trapped in the heating system piping.

With the boiler off, run the system pump for at least 30 minutes and bleed the system piping using the bleed valves. If strainers are used in the system piping, the make-up water valve should be closed and the strainers checked and cleaned.

The system expansion tank should be checked to ensure that the correct water level in the tank is maintained. The tank should be less than half full of water with the system full and adjusted to the correct operating pressure.

Start the boiler as described in the “Operating Instructions” section. Run the boiler for at least an hour. The system pump(s) and all radiation units must be operated during this time. Ensure that the make-up water valve is open.

Shut the boiler off and open the bleed valves to purge the air trapped in the heating system piping. Close the make-up water valve and check and clean the strainers and make-up water pressure reducing valve.

Open the make-up water valve and adjust the system pressure if necessary. The system should be checked and bled after three days of operation.

WIRING & CONTROL SET-UP

WARNING Follow the instructions in the Futera XLF Control installation and operation instruction manual shipped with the boiler to wire the boiler and set up the HeatNet control. The control must be set up before attempting to fire the boiler.

See Figure 17 for location of electrical components.

In addition to the information in the Futera XLF Control IOM, see the following information on controls and interlocks.

CONTROLS & INTERLOCKS

Low Water Cutoff

If the boiler is to be installed above radiation or if required by other codes or regulations, install a low water cutoff in appropriate piping. Wire the switch to the “Interlock” contacts as illustrated on “Field Wiring” schematic. Ensure that the low water cutoff device(s) will function properly.

Operating Control

The operating control should be set to the lowest setting that will satisfy the consumer’s needs.

WARNING Setting the thermostat or operation control too high can result in scalding resulting in severe personal injury!

High Limits (Aquamats)

The high limits are located in the top control area of the boiler. Remote capillary bulbs run to wells on the outlet side of the supply header. The high limit can be reset by depressing the red button.

The boiler high limit should be set to a minimum of **20°F, 11°C** higher than the operating control. Refer to the HOT WATER SUPPLY section for the proper supply water temperature.

Flow Switch

A flow switch is provided in the water outlet piping to prevent the boiler from firing without adequate water flow through the heat exchanger.

PROPANE GAS

WARNING Propane gas may not always be detected by smell. Propane gas is heavier than air and can collect in low areas.

Propane gas can ignite or explode if an ignition source is present and result in death, serious injury and property damage!

Figure 17 HeatNet Control Panel

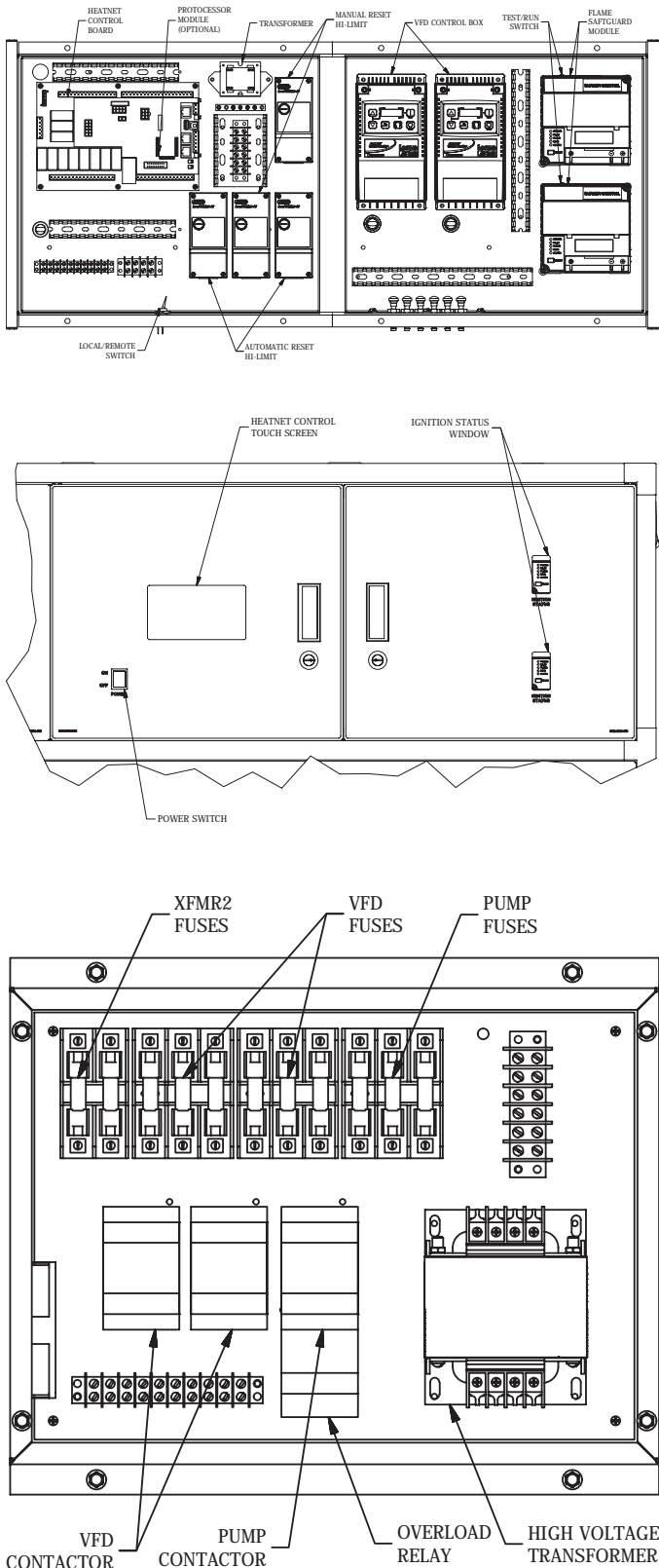

SEQUENCE OF OPERATION

NO DEMAND

Standby

1. The boiler is idle with no interlocks in the fault condition.

DEMAND

Pre-Purge

1. The blower operates at purge RPM. The water flow interlock must 'make' within 15 seconds after the demand signal is initiated.
2. The Honeywell 7800 starts a 10 second purge delay once the air prove switch contacts close.

Pilot Run - % Input

1. The blower operates at minimum ignition setting. See the calibration section in the "HeatNet Control-IOM" to enter the calibration menus.
2. The ignition transformer is energized. The pilot solenoid valve opens for the 10 second pilot ignition trial.

Main Run % Input

1. The main gas valve opens.
2. The ignition transformer is de-energized.
3. The pilot solenoid valve closes.
4. The blower stays at the minimum input setting for 3 seconds then operates at demand % input. See the calibration section in the "HeatNet Control IOM" to enter the calibration menus.

NO DEMAND

Post-Purge

1. The main gas valve closes.
2. The blower operates at purge RPM for 10 seconds.
3. The boiler is idle with no interlocks in the fault condition.

WARNING The following start-up procedure assumes that all water piping, gas piping and electrical connections are correct as stated in this manual and the installation meets all State, Local, and City codes.

NOTICE See the Futera XLF Control IOM for troubleshooting information and control operation.

OPERATING INSTRUCTIONS

Operating instructions

1. If, at any time, the boiler will not operate properly, follow the instructions “TO TURN OFF GAS TO APPLIANCE,” and call your service technician or gas supplier.
2. Turn off all electrical power to the boiler.
3. Close main gas shut-off valve (field supplied), Figure 16.
4. Purge the gas piping up to the boiler’s manual gas valve (located ahead of the main gas valve). When the bleeding is complete, check all gas joints up to the gas valve for leaks.
5. Wait five (5) minutes to clear out any gas.
6. Make sure all limits, pressures switches and safety device contacts are closed.
7. Open the main gas shut-off valve.
8. Disable any external call for heat, such as from a building management system or remote operating controller.
9. Toggle the remote/local switch (in control cabinet — see Figure 18) to **REMOTE**.
10. Turn on electrical power to the boiler.
11. Turn the power switch on the front of the boiler control cabinet to **ON**.
12. The HeatNet display will light up when the power is on. If all interlocks are properly closed, the display will say **STANDBY**. If not, refer to the XLF HeatNet Control IOM for troubleshooting.
13. Slide the HeatNet control’s low fire switch (on HeatNet control board) to the **LOW FIRE** position.
14. The boiler will begin the start-up sequence.
15. Allow the boiler to pre-purge and enter the pilot ignition cycle.
16. If pilot lights (indicated by a good flame signal 5.0 V DC) proceed to step 18. (See Honeywell R7800 literature for use of a meter to check flame signal if keypad readout is not available.)
17. If pilot is unstable (indicated by a low or erratic flame signal causing pilot flame failure), toggle the low fire switch to **DISABLE**, then back to **ENABLE** to start another cycle (reset the Honeywell control if necessary). Repeat for one or two more times to ensure the pilot line is purged of all air. If pilot is still unstable, the pilot gas pressure may need to be increased. See step 18.
18. Pilot pressure adjustment:
 - a. When the main display reads **PILOT RUNNING** switch both Honeywell 7800 test/run switches into the **TEST** position within the first 10 seconds of the pilot ignition sequence. This will hold the Honeywell 7800 controls in its ignition state. Both modules must be in the **TEST** position otherwise the unit will shutdown.

- b. Connect one side of a manometer or magnehelic gauge to each of the pilot gas pressure and air pressure ports (Left & Right Modules) located on the pressure test manifold inside the control panel. See Figure 18. Leave the other side of the manometer open to the room.

Figure 18 Manometer Connections to the Test Manifold (in control cabinet)

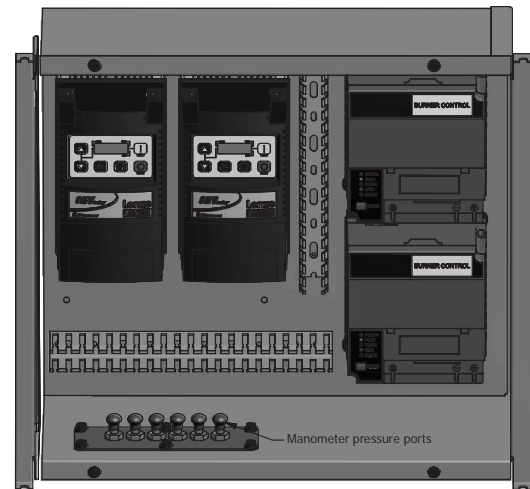

- c. Set pilot gas pressure to **3.0 in wc (± 0.5 in)** by adjusting the left & right side module pilot gas pressure regulators located inside the air box. Access from the boiler top cover. See Figure 19.

Figure 19 Access to Air Trim Adjustment and Pilot Regulator

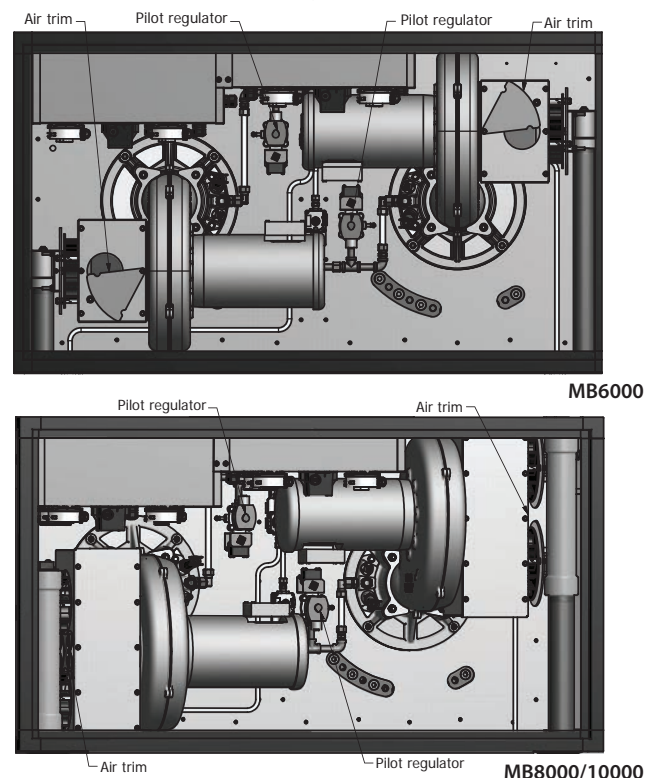

- d. Pilot air pressure should be **0.60 in wc (± 0.10 in)**.

WARNING Combustion readings must be in the range specified in the following instructions. Adjust the boiler as necessary to ensure proper combustion.

Verify low fire operation

1. Connect a manometer or magnehelic gauge with the pressure side to each of the (Left & Right Module) Ps signal ports. See Figure 18, for locations.
2. Set both Honeywell R7800 controls to **RUN** position. Both left and right burner modules will operate at low fire because the low fire switch is in the low fire position.
3. Measure the flue gas CO₂ with the boiler running at low fire. Set low fire CO₂ to, (Table 16 and 17), by adjustment on the Dungs valve using a 3mm Allen wrench. (Each module must be measured independently).
 - a. Turn the wrench in small increments (10° at a time).
 - b. Allow time after each adjustment for the boiler to reach steady state.
4. After setting the CO₂, measure the pressure signal, **Ps - (low fire)**.
 - a. The pressure at low fire should be as shown in Table 14 and 15.
 - b. If the pressure is outside this range, follow instructions in the XLF Control IOM to calibrate the firing rate. Increase rate if the pressure signal is low, or decrease rate if the signal is high.
 - c. Return to step 1 to adjust low fire CO₂ after changing low fire firing rate.

WARNING If using a U-tube manometer turned sideways for low pressure readings, you **MUST** turn the manometer upright before attempting to measure pressures at other than low fire. Pressure signal will reach up to **9 inches** when the boiler is at high fire, and can cause fluid to be pulled out of the manometer into the boiler. Should this occur, immediately shut down the boiler and contact the factory for procedure. Preferably, use a Magnehelic gauge instead of a U-tube manometer to measure the pressure to avoid this potential hazard.

Table 14 Pressure Signal (Ps) (Nat Gas) - Category I

| Firing rate % | 6000 | | 8000 | | 10000 | |
|---------------|-------------|--------------|-------------|--------------|-------------|--------------|
| | Left Module | Right Module | Left Module | Right Module | Left Module | Right Module |
| 100% | -6.1 | -6.6 | -8.6 | -8.6 | -7.6 | -8.2 |
| 85%* | -4.6 | -5.1 | -7.5 | -7.5 | -5.3 | -5.9 |

To determine signal in mm wc, multiply signal pressure by 25.4.
* Maximum turndown on units listed as CAT I

Table 15 Pressure Signal (Ps) (Nat Gas) - Category II and IV

| Firing rate % | 6000 | | 8000 | | 10000 | |
|---------------|-------------|--------------|-------------|--------------|-------------|--------------|
| | Left Module | Right Module | Left Module | Right Module | Left Module | Right Module |
| 100% | -6.8 | -6.6 | -8.2 | -8.2 | -7.6 | -7.8 |
| 33% | -0.8 | -0.8 | -1.2 | -1.2 | -0.8 | -0.9 |
| 25% | -0.5 | -0.5 | -0.8 | -0.8 | -0.5 | -0.6 |
| 20% | -0.3 | -0.3 | -0.3 | -0.3 | -0.3 | -0.3 |

To determine signal in mm wc, multiply signal pressure by 25.4.

WARNING Correctly identify the type of vent system the appliance requires before proceeding. Category identification is noted on the unit rating plate.

For LP Gas: All units are tested at factory. LP Combustion Values are located on Combustion Data label.

WARNING To ensure proper boiler operation, boilers (CAT IV) that use room air and vented side wall must not be fired at less than 33% input.

5. Observe the burner flame after setting low fire. Make sure the flame is stable, but not too tight on the burner (causing infrared operation).

WARNING **DO NOT LEAVE THE BURNER IN AN INFRARED STATE.** A few random speckles of red are acceptable, but large concentrations of spots or large areas of red are not. If large amounts of red concentrations are observed, verify combustion readings.

NOTICE Leave the manometer connected to the test manifold. It will be needed for high fire operation testing.

Verify high fire operation

1. Jumper the AA terminals on the HeatNet board and allow the boiler to rise to maximum (100%) input.
2. Allow the boiler to reach steady state combustion at high fire.
3. Verify high fire blower speed as follows:
 - a. With the manometer (or gauge) connected to the (Left & Right Module) Ps signal port, measure the pressure signal, **Ps - (high fire)**.
 - b. The pressure at high fire should be as shown in Table 14 and 15.
 - c. If the pressure is NOT correct, follow step 4.
4. If the high fire signal pressure is not correct:
 - a. Remove the jumper on AA. The boiler will return to low fire.
 - b. Follow the instructions in the XLF Control IOM to calibrate the high fire firing rate. (Slide the HeatNet control calibrate switch to **CAL**. Follow the Control IOM procedure to navigate to the HeatNet control calibration screen.)

WARNING The maximum firing rate value in the HeatNet control is factory set at 90%. At this setting, at sea level, and with typical vent length, the **boiler will be at rate**. **DO NOT** increase the HeatNet control's maximum rate setting above 90% unless needed for high altitude installations.

- c. If **Ps** is too high, reduce the HeatNet control's maximum firing rate setting by 2%. Then slide the calibration switch to **NORMAL** and exit the HeatNet control's calibration screens. Replace the jumper on AA and allow the boiler to return to high fire. Return to step 2 to repeat the process. If necessary, repeat this sequence, reducing the firing rate by 2% each time.
- d. If **Ps** is too low, increase the firing rate setting by 2%. Then slide the calibration switch to **NORMAL** and exit the HeatNet control's calibration screens. Replace the jumper on AA and allow the boiler to return to high fire. Return to step 2 to repeat the process. If necessary, repeat this sequence, increasing the firing rate by 2% each time.
- e. Check the pressure signal again. If the signal is now correct, reconnect the jumper on AA and proceed to step 5.
- f. If the pressure signal doesn't respond to the minor adjustment contact factory technical support to troubleshoot the pressure signal issue.

5. If the pressure signal is correct, measure the flue gas CO₂. Refer to "Combustion Reading" Tables 16 and 17 for proper combustion readings.
(Each module must be measured independently).
 - a. If CO₂ is correct, proceed to step 6.
 - b. If CO₂ is not within this range, adjust the air trim adjustment slightly (see Figure 19) on mixing box to achieve proper combustion.
 - c. If adjusting the air trim adjustment does not correct the problem, contact technical support at the factory to troubleshoot the problem.
6. If CO₂ and pressure signal are correct, allow the boiler to reach steady state and verify supply gas pressure and check input rates as explained in the Gas Supply Piping section.
7. Remove jumper on AA and allow boiler to settle into minimum input. Observe the combustion readings to ensure the boiler is operating correctly.
8. When finished, disable the low fire hold switch and replace test ports to normal state. Remove the manometer connections and close the control panel door.
9. The Futera XLF boiler allows for many modes of operation and control methods. Reference the XLF HeatNet Control IOM.

TO TURN OFF GAS TO APPLIANCE

1. Set the operating control to its lowest setting.
2. Turn off all electric power to the boiler if service is to be performed.
3. Close the manual main and pilot gas shut-off valves.

Table 16 Combustion Readings (Category I)

| | Natural Fuel | Propane Fuel |
|-------------------|------------------|-------------------|
| CO ₂ % | 8.0 - 8.3 (min.) | 9.4 - 9.7 (min.) |
| | 8.3 - 8.6 (100%) | 9.7 - 10.0 (100%) |
| O ₂ % | 6.6 - 6.0 (min.) | 6.6 - 6.0 (min.) |
| | 6.0 - 5.5 (100%) | 6.0 - 5.5 (100%) |

Table 17 Combustion Readings (Category II and IV)

| | Natural Fuel | Propane Fuel |
|-------------------|------------------|--------------------|
| CO ₂ % | 8.0 - 8.5 (min.) | 9.4 - 9.9 (min.) |
| | 8.8 - 9.8 (100%) | 10.3 - 11.5 (100%) |
| O ₂ % | 6.6 - 5.8 (min.) | 6.6 - 5.8 (min.) |
| | 5.2 - 3.5 (100%) | 5.2 - 3.5 (100%) |

CHECKING & ADJUSTMENTS

WARNING Proper polarity of the ignition transformer wiring is import. Improper wiring of the ignition transformer can result in an explosion causing extensive property damage, severe personal injury or death!

Spark gap

With the main and pilot gas manual valves in the closed position energize the unit. Look through the sight glass in the pilot tube to observe the trial for ignition. Make sure that the spark is strong and continuous. If not, check and adjust the spark gap as shown in Figure 20.

Figure 20 Spark Gap

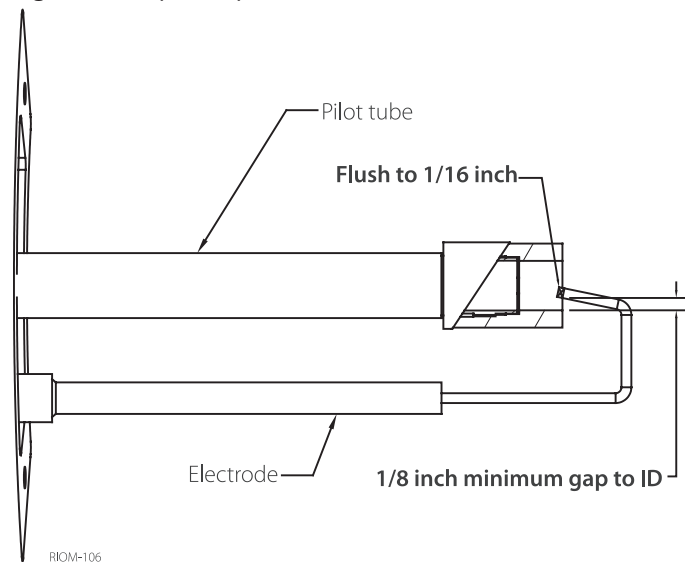

Pilot adjustment

1. The pilot pressure has been factory set at **3 in WC**, and shouldn't need adjustment.
 - a. With the boiler powered, generate a call for heat.
 - b. When the prepurge is complete the ignition/pilot trial will begin.
2. To adjust the pilot the following steps must be taken:
 - a. Put the Honeywell RM7800 test switch in the test position. The control will hold in the ignition/pilot sequence, allowing you to check the pressure.
 - b. Connect one side of a manometer or pressure gauge to the manometer pressure port (barbed) on the pressure test manifold (located inside control panel). See figure 18. Leave the other side of the manometer open to the room.
 - c. Measure pilot gas pressure by pressing and holding the service valve marked **PILOT GAS**.
 - d. Set pilot gas pressure to **3.0 in wc (± 0.5 in)** by adjusting the pilot gas pressure regulator, inside the air box. Access from the boiler top cover. See Figure 19.
 - e. Check pilot air pressure using service valve marked **PILOT AIR**.
 - f. Pilot air pressure should be **0.60 in wc (± 0.10 in)**.

CAUTION Never force the regulator adjustment screw beyond the stop limits or damage to the regulator will occur!

Required gas pressure

Provide gas supply pressure at inlet to boiler gas train as follows:

| Gas Supply Pressure (Nat/LP) | | |
|------------------------------|--------------------------------|----------------------------|
| | Inches water column | <i>mm water column</i> |
| Minimum (in WC) | 3.5 | 88.9 |
| Maximum (in WC) | 14 | 356 |

1. Measure pressure when the boiler is firing at full rate. Low gas pressure could indicate undersized gas line or insufficient gas supply.
2. Static and operating gas pressure required at the gas valve inlet is listed in the Table above.

WARNING If the gas pressure is above the limit in the table below, a lock-up style gas pressure regulator suitable for dead-end service, (such as an Equimeter or Fisher) must be installed to prevent increase (creep) of gas pressure when the units are not operating. Gas supply pressure, as indicated in the table below, must be maintained to the inlet of the boiler gas train not to exceed a maximum (1.0 in WC) drop when firing from minimum input to full load of the gas supply line and all the appliances running.

This pressure regulator (supplied by others) may be installed at the service entrance to each unit or a "master" regulator sized to handle multiple units may be utilized. Consult local gas utility or regulator manufacturer for recommendations to meet specific job site requirements.

Input rate — Natural gas

Gas appliances are rated based on sea level operation with no adjustment required at elevations up to **2000 ft, 610 m**. At elevations above **2000 ft, 610 m** input ratings should be reduced by 4% for each **1000 ft, 305 m**.

Check the input rate as follows:

1. Turn off all other gas appliances that use the same gas meter as the boiler.
2. Call your gas supplier and ask for the heating value of the gas.
3. Start the boiler and let it run for 15 minutes.
4. Using the gas meter and a stopwatch, clock the time that it takes to burn **10 ft³, 0.28 m³** of gas and divide this time by 10.
5. Insert the heating value and the time, in seconds, into the formula below.
6. $\text{Input} = (\text{heating value, Btu/hr})(3600)/(\text{time, seconds})$
7. If the computed rate deviates by more than 5% from the rated input value of the unit, consult factory.

CAUTION Never increase the input to the boiler above that for which it is rated. Doing so can cause premature failure of the boiler!

MAINTENANCE

WARNING Disconnect electrical power and close the manual gas shut off valve before performing maintenance or severe personal injury may result!

CAUTION Servicing, inspection and adjustment must be done by a trained technician in accordance with all applicable local and national codes. Improper servicing or adjustment can damage the boiler!

The boiler must be cleaned and inspected at least once a year and before each heating season. Make sure that the burner and ignition components are free from dust, soot, dirt, corrosion or other deposits that would impair the boiler's performance. Refer to Figure 20, for component identification.

CAUTION Improper burner servicing can result in premature burner failure voiding the warranty!

Pilot and burner removal

1. Close the manual shutoff valves in the gas supply line and turn off electrical power to the boiler.
2. Remove the jacket top panel.
3. Remove wires from the spark rods and remove the UV sensor from the transition piece.
4. Remove the pilot assembly:
 - a. Disconnect the compression nut at the front of the pilot block.
 - b. Remove the pilot gas tubing.
 - c. Remove the (2) screws from the pilot block.
 - d. Remove the pilot assembly.
5. Disconnect the flexible gas line from the manifold.
6. Disconnect the wires to the fan and remove the (2) bolts and the fan hold-down plates that secure the fan to the transition piece.
7. Lift and remove the fan housing from the boiler, taking care not to damage the spark rods and or their alignment.
8. Remove the four nuts holding the transition piece to the heat exchanger.
9. Remove the transition piece, taking care not to damage the o-ring.
10. Remove the burner, taking care not to damage the gasket.
11. Replace all components after servicing.

Heat exchanger inspection

1. Close the manual shutoff valves in the gas supply lines and turn off electrical power to the boiler.
2. Remove burner following the instructions in the Burner Removal section.

3. Remove the front jacket panel and combustion chamber door.
4. Inspect the inside and outside of the heat exchanger for signs of damage, sooting or corrosion.
5. The outside surfaces of the copper tubes should be free of any soot deposits. A slight black smudge is normal with some types of gases. Black soot indicates poor combustion. Green deposits indicate condensation due to low return water temperatures. In either case the heat exchanger must be cleaned thoroughly and the problem resolved before the boiler is returned to service.
6. If there are no signs of damage, sooting or corrosion, reassemble the unit following the previous steps in reverse order.
7. A badly corroded or damaged heat exchanger must be replaced, see the Heat Exchanger Repair & Replacement section.

Heat exchanger cleaning

1. Close the shut off valves in the inlet and outlet piping. On heating systems close the system fill valve and relieve the system pressure from the boiler by carefully lifting the relief valve or opening the drain valve.
2. Disconnect the boiler from the system piping.
3. Remove the eight bolts on the rear pipe enclosure panel.
4. Remove the front jacket panel and combustion chamber door.
5. Slide the heat exchanger out of the unit.
6. Remove the "V" baffle straps and "V" baffles.
7. Thoroughly clean the heat exchanger with water from a high-pressure hose. Use a soft bristle brush if necessary.
8. Replace the cleaned heat exchanger and other components in the reverse order of their removal.

Heat exchanger repair & replacement

1. A leaking or otherwise damaged tube(s) can be replaced as outlined in steps 2 through 8.
2. Remove the heat exchanger from the boiler as outlined in the Heat Exchanger Cleaning section.
3. Remove the pipe plugs from the inlet/outlet and return headers opposite from the ends of the tube(s) being replaced.
4. Carefully cut the damaged tube(s) in half, taking care not to damage the adjacent tubes and remove.
5. Install and swage/expand in place the new tube(s).

6. Replace the pipe plugs using a suitable thread sealant on each one.
7. Sagging or distorted heat exchanger tubes are an indication of low water flow through the system. A damaged heat exchanger must be replaced and the condition that caused the damage resolved before the boiler is returned to service.
8. Replace the heat exchanger and other components in the reverse order of their removal.

Air intake & vent system

Thoroughly inspect the air intake and vent systems for any signs of blockage, corrosion or leakage. Immediately replace any unsound vent system piping. Inspect the air filter and wash with warm water and soap if dirty.

Controls

Use the “GENERAL OPERATION” and “CHECKING AND ADJUSTMENTS” sections of this manual for reference.

1. Check the operating controls for proper operation.
2. A float type low water cutoff device must be flushed out per the manufacturers’ instructions.
 - a. The probe on a probe low water cut off must be removed, cleaned and inspected at least once a year.
 - b. Ensure that the low water cutoffs operate properly. If not, replace them.
3. The flow switch contacts must be open when water flow is not present.
4. The relief valve should not weep or discharge water at normal system pressure. If it does, contact a qualified service technician to have it inspected.

WARNING NEVER try to clean or repair the relief valve! If the valve fails to operate properly, have it replaced!

5. The aquastat high limit controls the maximum water temperature in the boiler.
 - a. If the water temperature reaches the set temperature before the demand for heat has been met, the aquastat high limit should shut the boiler off.
 - b. The water temperature should never exceed the maximum set point of **250°F, 121°C**, for boilers.
 - c. The aquastat high limit cannot be repaired. If it fails to function properly, replace it.
6. Visually check the pilot and main burner flames to ensure proper operation, see Figure 21.

WARNING A yellow, floating flame indicates a lack of combustion air. Do not operate the boiler until the problem is solved or severe personal injury or death may occur!

Figure 21 Main Burner Flame

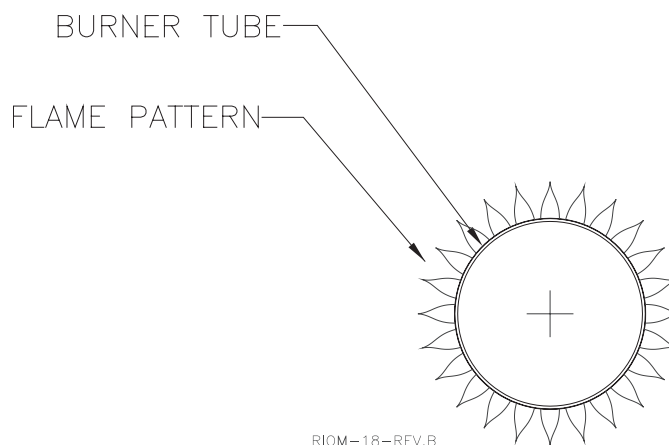

Manometer test port manifold

1. The Futera XLF includes a manometer test manifold. Connect the manometer pressure hose to the Pressure Tap port shown in Figure 22. These pressure signals may be used for troubleshooting when specified by factory support.

Figure 22 Manometer Connections to Manifold

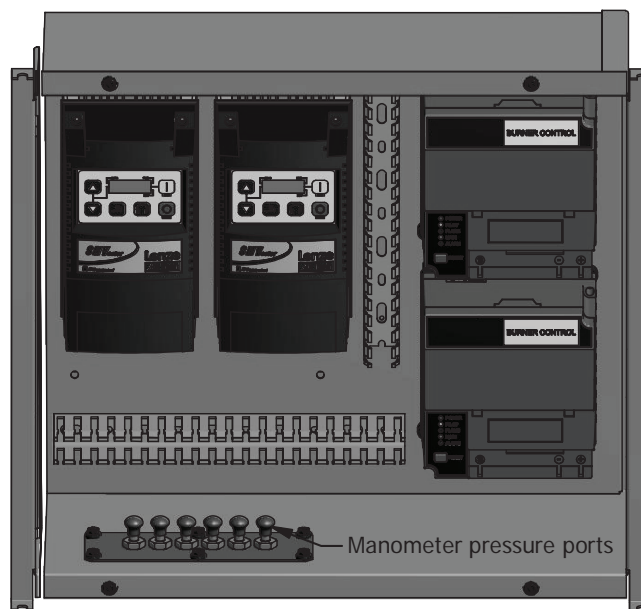
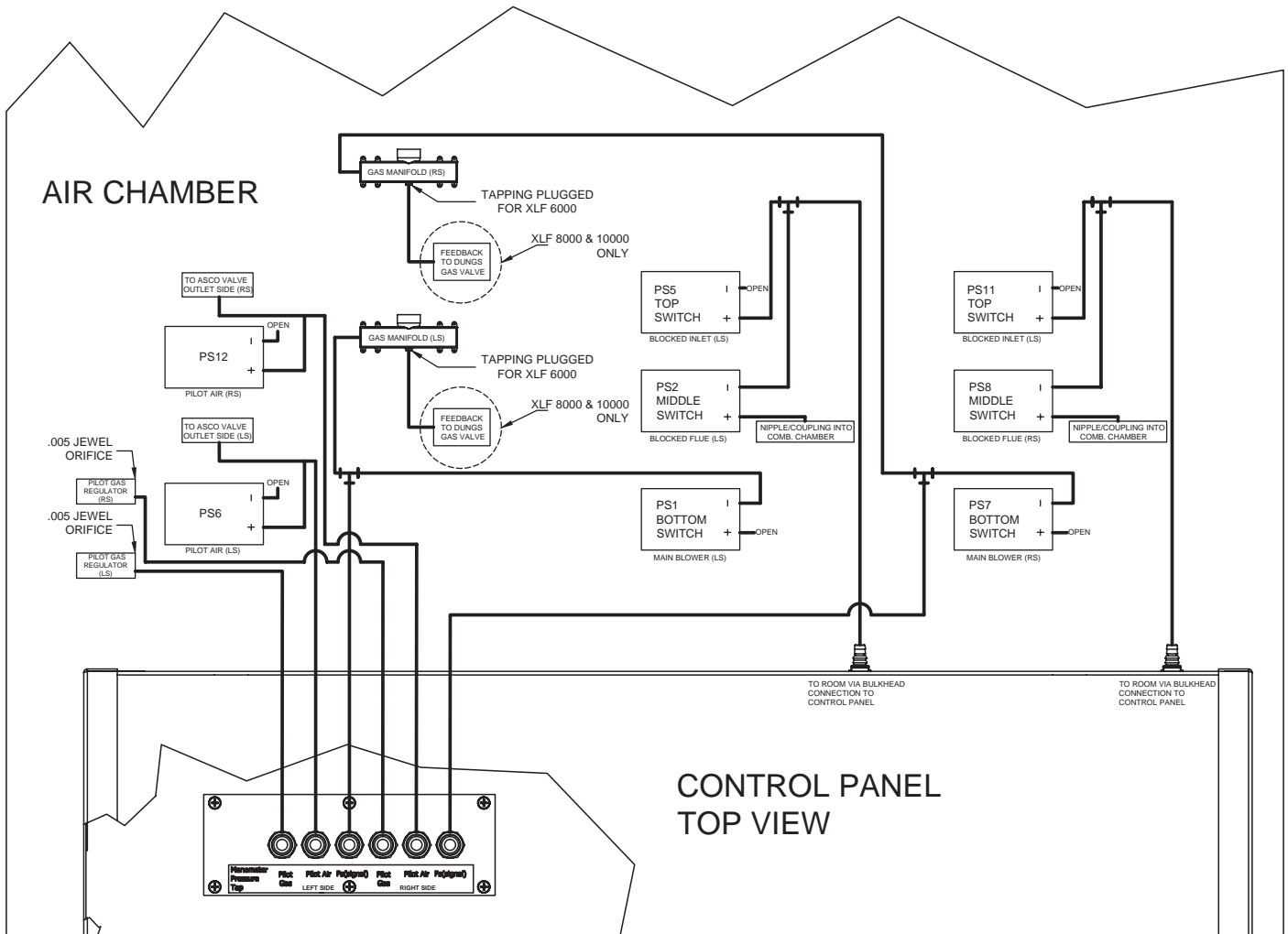

Figure 23, shows the sensor hose connections inside the Futera XLF air box.

Figure 23 Futera XLF Pressure Sensor Hose Routing

| SWITCH SETTINGS IN "W.C." | | | | |
|---------------------------|--------------------|----------|----------|----------|
| SWITCH | FOR | 6000 | 8000 | 10000 |
| PS1 | MAIN BLOWER (LS) | (-) 0.20 | (-) 0.20 | (-) 0.20 |
| PS2 | BLOCKED FLUE (LS) | (+) 2.0 | (+) 2.0 | (+) 2.0 |
| PS5 | BLOCKED INLET (LS) | (-) 2.0 | (-) 2.0 | (-) 2.0 |
| PS6 | PILOT AIR (LS) | (+) 0.36 | (+) 0.36 | (+) 0.36 |
| PS7 | MAIN BLOWER (RS) | (-) 0.20 | (-) 0.20 | (-) 0.20 |
| PS8 | BLOCKED FLUE (RS) | (+) 2.0 | (+) 2.0 | (+) 2.0 |
| PS11 | BLOCKED INLET (RS) | (-) 2.0 | (-) 2.0 | (-) 2.0 |
| PS12 | PILOT AIR (RS) | (+) 0.36 | (+) 0.36 | (+) 0.36 |



REPAIR PARTS

Figure 24 Exploded View

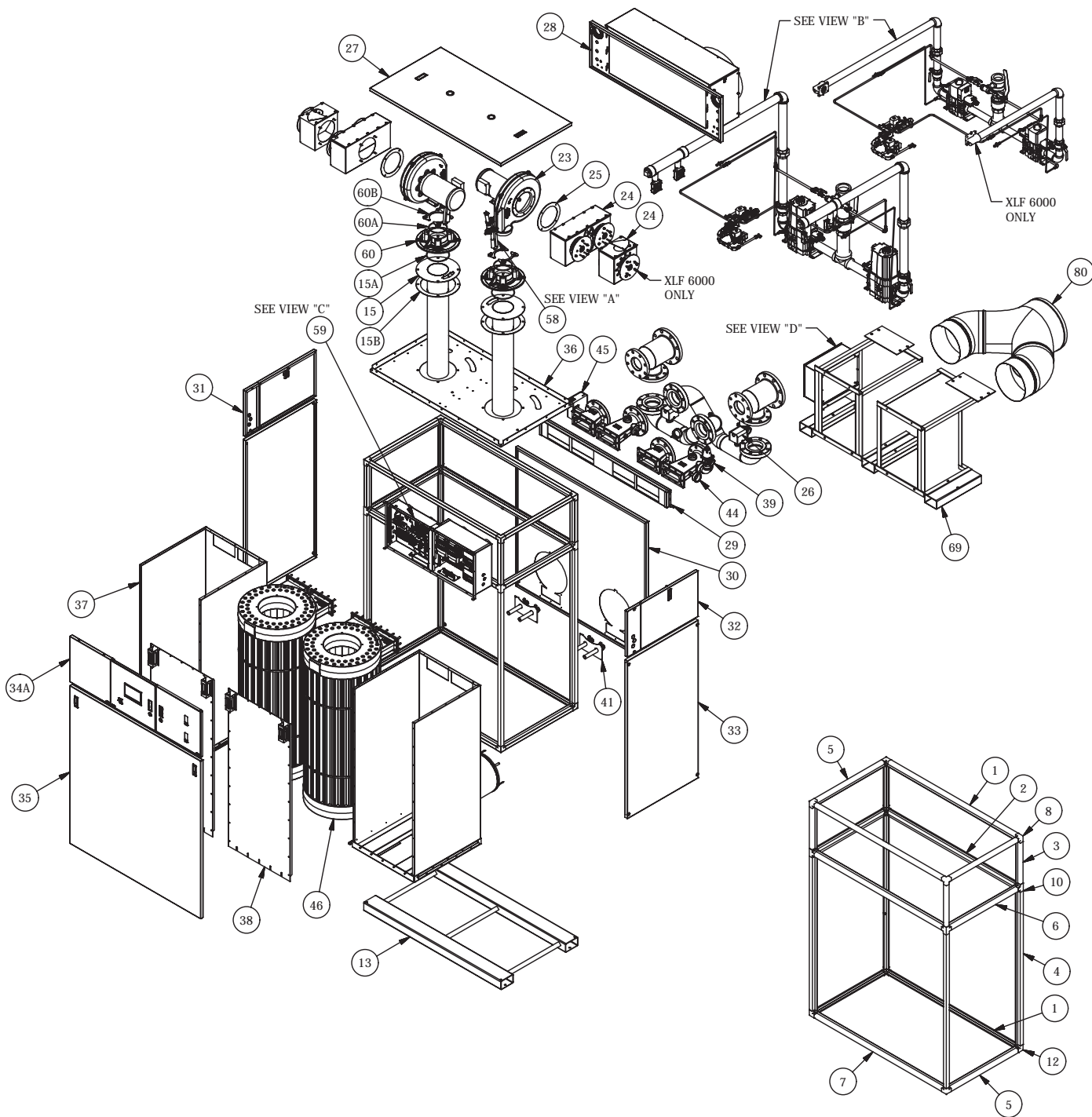

REPAIR PARTS (CONTINUED)

Figure 25 Figure 20 – Electrical Components

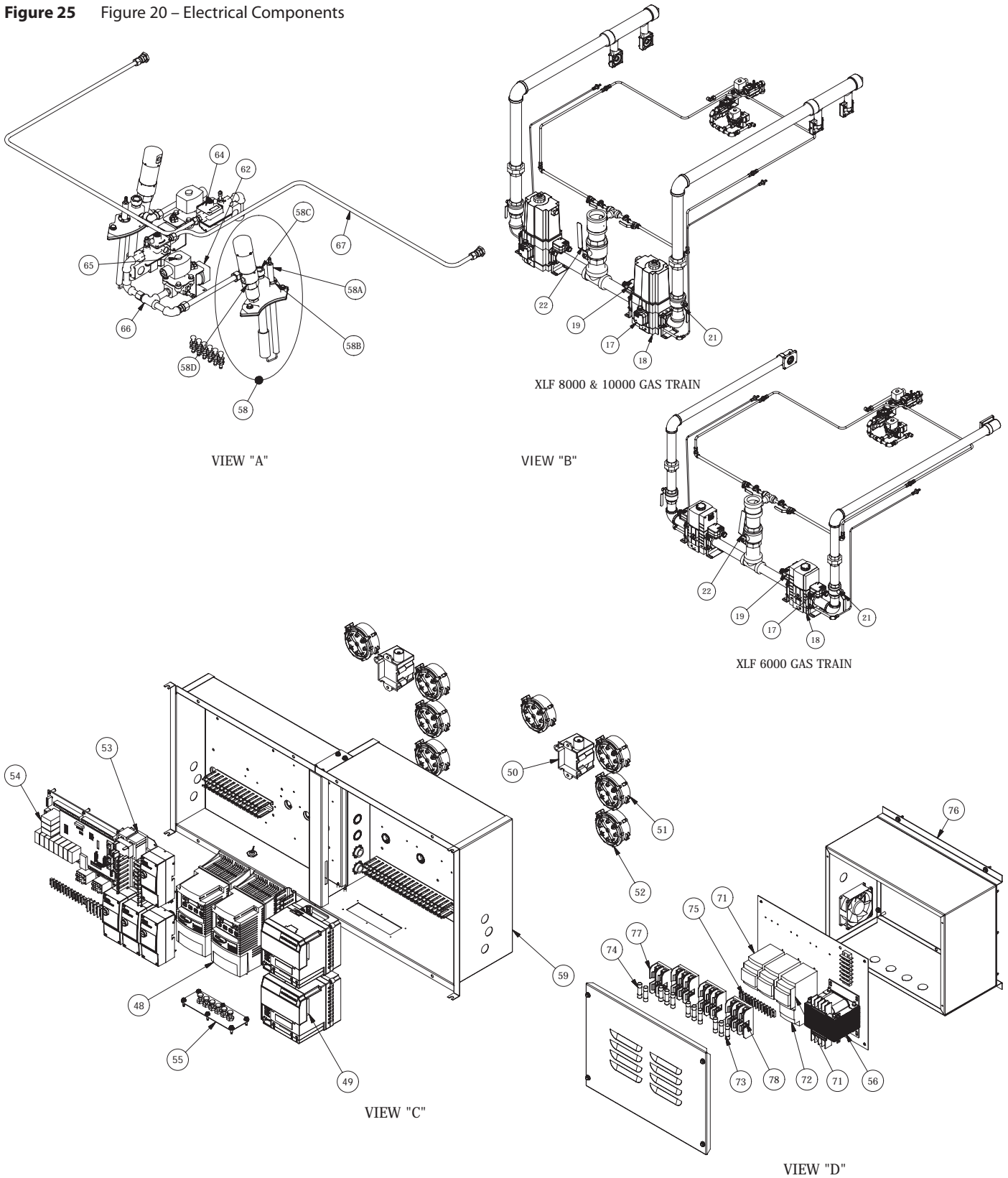

REPAIR PARTS (CONTINUED)

| Ref # | Name of Part | Part # | Model Size with item Quantities Below | | |
|-------|--|-----------------------------|---------------------------------------|------|-------|
| | | | 6000 | 8000 | 10000 |
| 15 | Burner | 10-0293 | 2 | | |
| | | 10-0294 | | 2 | |
| | | 10-0324 | | | 2 |
| 15a | Burner O'ring | (must order as kit 21-2009) | | | |
| 15b | Burner Gasket | (must order as kit 21-2009) | | | |
| 17 | High Gas Pressure Switch (Manual Reset) | 11-0421 | 2 | 2 | 2 |
| 18 | Gas Valve, MBC (NG) | 11-0223 | 2 | | |
| | Gas Valve, MBC (LP) | 11-0227 | 2 | | |
| | Filter Element (MBC 2500) | 11-0652-002 | 2 | | |
| | Filter Element (MBC 2500) Pkg of 10 | 11-0652-001 | 2 | | |
| | Gas Valve, MBC | 11-0218 | | 2 | 2 |
| | Filter Element (MBC 4000) | 11-0653-002 | | 2 | 2 |
| | Filter Element (MBC 4000) Pkg of 10 | 11-0653-001 | | 2 | 2 |
| | Test Port (CSD-1) | 11-0354 | 4 | 4 | 4 |
| NS | Flange 1 1/2" (Inlet) | 11-0214 | 4 | | |
| | Flange 2" (Inlet) | 11-0219 | | 4 | 4 |
| 19 | Low Gas Pressure Switch (Manual Reset) | 11-0422 | 2 | 2 | 2 |
| 21 | Firing Valve, 1 1/2" | 11-0458 | 2 | | |
| | Firing Valve, 2" | 11-0459 | | 2 | 2 |
| 22 | "A" Valve, 1 1/2" | 11-0467 | 1 | | |
| | "A" Valve, 2" | 11-0454 | | 1 | 1 |
| 23 | Blower (230V/460V) | 12-0019K | 2 | | |
| | Blower (575V) | 12-0019-002K | 2 | | |
| | Blower (208-230/460V) | 12-0023K | | 2 | 2 |
| | Blower (575V) | 12-0023-002K | | 2 | 2 |
| NS | Gas Injectors, NG | 10-1007 | 2 | | 2 |
| | | 10-1002 | | 2 | |
| | Gas Injectors, LP | 10-1008 | 2 | | 2 |
| | | 10-1004 | | 2 | |
| 26 | Flow Switch | 14-0205 | 2 | 2 | 2 |
| 27 | Jacket Top Panel | 70-3631 | 1 | 1 | 1 |
| 28 | Air Filter | 09-0501-001 | 1 | 1 | 1 |
| NS | Handle | 20-0044 | 1 | 1 | 1 |
| 35 | Lower Front Jacket Panel | 70-3629-001 | 1 | | |
| | | 70-3629-002 | | 1 | |
| | | 70-3629-003 | | | 1 |
| 36 | Combustion Chamber Top Panel | 03-3971-001 | 1 | 1 | 1 |
| | Manning Glass Insulation (per square foot) | 05-0104 | 18 | 18 | 18 |
| NS | 2" Blanket Insulation (per sq ft) | 05-0200 | 66 | 72 | 72 |
| | Red Silicone Gasket (per ft / sold per roll 50') | 06-0146 | 100 | 100 | 100 |
| 39 | Pressure Relief Valve 50# | 30-0382 | 2 | | |
| | Pressure Relief Valve 50# | 13-0026 | | 2 | |
| | Pressure Relief Valve 50# | 13-0036 | | | 2 |
| | Pressure Relief Valve 125# | 13-0003 | 2 | | |
| | Pressure Relief Valve 125# | 13-0053 | | 2 | |
| | Pressure Relief Valve 125# | 13-0024 | | | 2 |
| NS | Latch | 20-0045 | 2 | 2 | 2 |
| NS | Ball Valve | 11-0395 | 2 | 2 | 2 |
| NS | Condensate Trap Kit | 75-0201 | 2 | 2 | 2 |
| 44 | Tridicator 30 - 60 psi | 13-0308 | 2 | 2 | 2 |
| | Tridicator 75 - 160 psi | 13-0305 | 2 | 2 | 2 |
| 45 | LWCO #550LSV | 14-0256 | 2 | 2 | 2 |

REPAIR PARTS (CONTINUED)

| Ref # | Name of Part | Part # | Model Size with item Quantities Below | | | |
|-------|--|--|---------------------------------------|------|-------|---|
| | | | 6000 | 8000 | 10000 | |
| 46 | Heat Exchanger Assembly (Copper) Cast Iron | 70-3819-002R | 2 | | | |
| | | 70-3819-004R | | 2 | | |
| | Individual copper/cupronickel tubes (available for field repair) model and serial number required | | | | | |
| | | Tube Expansion Tool | 30-0761 | 1 | 1 | 1 |
| | | Heat Exchanger Assembly (Cupronickel) Cast Iron | 70-3820-002R | 2 | | |
| | | 70-3820-004R | | 2 | | |
| | | 70-3820-005R | | | 2 | |
| NS | Heat Exchanger "V" Baffles | 03-3998 | 56 | | | |
| | | 03-4000 | | 56 | | |
| | | 03-3822 | | | 56 | |
| | Heat Exchanger "V" Baffle Strap | 03-3946 | 4 | 4 | 4 | |
| 47 | Flange Gasket | (must order as kit 21-2009) | | | | |
| 48 | Frequency Drive (208-240V) | 15-0238-001 | 2 | | | |
| | Frequency Drive (460V) | 15-0238-002 | 2 | | | |
| | Frequency Drive (575V) | 15-0238-003 | 2 | | | |
| | Frequency Drive (208-240V) | 15-0239-001 | | 2 | 2 | |
| | Frequency Drive (460V) | 15-0239-002 | | 2 | 2 | |
| | Frequency Drive (575V) | 15-0239-003 | | 2 | 2 | |
| 49 | Flame Safeguard, RM7895C | 16-0024R | 2 | 2 | 2 | |
| 50 | Spark Generator | 16-0036 | 2 | 2 | 2 | |
| 51 | Air Pressure Switch | 11-0419 | 4 | 6 | 6 | |
| 52 | Fan Prove Switch | 11-0420 | 2 | 2 | 2 | |
| | | 11-0419 | 2 | 2 | 2 | |
| 53 | Transformer, 50 VA | 15-0007 | 2 | 2 | 2 | |
| NS | High Limit, Jumo, (MB) | 14-0013 | 2 | 2 | 2 | |
| NS | High Limit, Jumo, (MB) Auto Reset | 14-0114 | 2 | 2 | 2 | |
| NS | Thermometer Well, 3/8 x 2 | 13-0102 | 4 | 4 | 4 | |
| NS | High Limit Well, 3/8 x 3 | 13-0104 | 4 | 4 | 4 | |
| 54 | Main Board (HeatNet) Lite | 16-0047 | 1 | 1 | 1 | |
| | Main Board (HeatNet) Full | 16-0046 | 1 | 1 | 1 | |
| | Display Board (Touchscreen) | 40-0091-002 | 1 | 1 | 1 | |
| NS | Ignition Cable | 44-0063 | 2 | 2 | 2 | |
| NS | Ribbon Cable | 40-0115 | 1 | 1 | 1 | |
| NS | Power Switch | 48-0013 | 1 | 1 | 1 | |
| NS | Toggle Switch Remote/Local | 48-0014 | 1 | 1 | 1 | |
| NS | 10K Temperature Sensor | 14-0325 | 3 | 3 | 3 | |
| NS | Purge Timer, ST7800 | 16-0007 | 2 | 2 | 2 | |
| NS | Keyboard Display Module, S7800A | 16-0010 | 2 | 2 | 2 | |
| 58 | Pilot/Flame Rod Kit | 70-3615 | 2 | 2 | 2 | |
| 58a | Electrode | 16-0335 | 2 | 2 | 2 | |
| 58b | O'ring | 06-0008 | 2 | 2 | 2 | |
| 58c | View Port Assembly | 70-2205 | 2 | 2 | 2 | |
| 58d | Mini Peeper, C7027A (not included in 70-3615) | 16-0009 | 2 | 2 | 2 | |
| NS | Turbo Pilot Torch | 70-2559 | 2 | 2 | 2 | |
| NS | Pilot Spark Block | 01-0205 | 2 | 2 | 2 | |
| NS | UV Amplifier, R7849B | 16-0037 | 2 | 2 | 2 | |
| 60a | Blower O'ring | 06-0004 | 2 | 2 | 2 | |
| NS | Fan Orifice Funnel | 04-1016 | 2 | 2 | 2 | |
| 62 | Mini Fan | 12-0021 | 2 | 2 | 2 | |
| NS | 2P Terminal Block | 48-0163 | 2 | 2 | 2 | |
| 64 | Pilot Valve | 11-0079 | 2 | 2 | 2 | |
| 65 | Air Shut Off Valve | 11-0376 | 2 | 2 | 2 | |

REPAIR PARTS (CONTINUED)

| Ref # | Name of Part | Part # | Model Size with item Quantities Below | | |
|-------|-------------------------------------|---------------|---------------------------------------|------|-------|
| | | | 6000 | 8000 | 10000 |
| 66 | Pilot Orifice, .052 NG | 10-0140 | 2 | 2 | 2 |
| | Pilot Orifice, .040 LP | 10-0139 | 2 | 2 | 2 |
| 67 | Pilot Tube 3/8 | 62-0102-03918 | 1 | 1 | 1 |
| 70 | Power Relay | 15-0118 | 2 | 2 | 2 |
| 71 | VFD Contactor | 15-0208 | 2 | 2 | 2 |
| 72 | Relay Overload (9 - 13 Amp) 3HP | 15-0215 | 1 | | |
| | Relay Overload (12 - 18 Amp) 5HP | 15-0219 | | 1 | |
| | Relay Overload (6.4 - 32 Amp) 7.5HP | 15-0224 | | | 1 |
| 73 | Fuse, 3HP, 230V (pump) | 48-0627 | 3 | | |
| | Fuse, 5HP, 460V (pump) | 48-0639 | | 3 | |
| | Fuse, 7.5HP, 600V (pump) | 48-0646-3000 | | | 3 |
| 74 | Fuse, 15Amp, 600V (VFD) | 48-0609-1000 | 6 | 6 | 6 |
| 79 | Keypad Overlay | 82-0754-004 | 1 | 1 | 1 |
| NS | Rating Plate | 82-0054 | 1 | 1 | 1 |
| NS | Futera XLF Overlay (Left Side) | 82-0754-001 | 1 | 1 | 1 |
| | Futera XLF Overlay (Center) | 82-0754-002 | 1 | 1 | 1 |
| | Futera XLF Overlay (Right Side) | 82-0754-003 | 1 | 1 | 1 |
| 80 | Flue Outlet | 09-0602-001 | 1 | | |
| | | 09-0602-002 | | 1 | |
| | | 09-0602-003 | | | 1 |
| NS | Silicone Tubing | 06-0051 | per foot | | |
| NS | Silicone | 66-0151 | 2 | 2 | 2 |
| NS | Vent Termination Hood 12" | 09-0116 | 1 | | |
| | Vent Termination Hood 14" | 09-0141 | | 1 | |
| NS | Air Intake Hood 12" | 09-0105 | 1 | | |
| | Air Intake Hood 14" | 09-0106 | | 1 | |

START-UP REPORT



| | |
|---------------|-----------|
| DATE: | JOB NAME: |
| TECHNICIAN: | LOCATION: |
| COMPANY: | MODEL: |
| PHONE NUMBER: | SERIAL #: |

PRE-STARTUP CHECK LIST

- NO VISIBLE DAMAGE TO UNIT
- PIPING PROPERLY CONNECTED
- BOILER CIRCULATOR WIRED
- VENT/STACK CONNECTED
- INLET AIR FILTER INSTALLED AND CLEAN
- PROPER SERVICE CLEARANCES PROVIDED
- PUMP RUNNING, HEAT EXCHANGER FULL
- GAS LINES PURGED, NO LEAKS, NO MISSING TEST PLUGS

BOILER STARTUP SEQUENCE

Note: Locate the AA terminals and minimum hold switch in the bottom-right of the electrical panel on the main HeatNet board. Also locate the manometer test manifold in the bottom of the electrical panel.

1. Disable any external call for heat and toggle the remote/local switch to REMOTE.
2. Toggle the LOW FIRE switch to cycle the boiler then hold at trial for pilot ignition.
3. Set pressure to 3–3.5" WC (flame signal should read 5.0 VDC). (Reference XLF Boiler IOM.)
4. Release boiler to main flame trial for ignition.
5. Check for stable flame.
6. Record combustion and pressure signal (Ps) at minimum firing rate. (Reference XLF Boiler IOM.)
7. Jumper the AA terminals to force 100% input.
8. Record combustion and pressure signal (Ps). (Reference XLF Boiler IOM.)
9. Remove the AA jumper to place the boiler at minimum rate.
10. Record combustion and pressure signal (Ps). (Reference XLF Boiler IOM.)
11. Check all combustion results using a calibrated flue gas analyzer.
12. Release the LOW FIRE switch to place boiler in standby.

NOTICE

In addition to completing the Futera XLF start-up report, complete the control set-up information in the rear of the Futera XLF Control Installation and operation manual.

| COMBUSTION ANALYSIS | MINIMUM FIRING RATE | 100% FIRING RATE |
|----------------------------------|---------------------|------------------|
| GAS PRESSURE AT SUPPLY TEST PORT | IN WC | IN WC |
| CO ₂ | % | % |
| O ₂ | % | % |
| CO (PPM) | PPM | PPM |
| NET STACK TEMPERATURE | °F | °F |
| PRESSURE SIGNAL (Ps) | IN WC | IN WC |

SAFETY TEST CHECKLIST

- FLOW SWITCHES
- AIR SWITCH
- FLAME SAFEGUARD
- LOW WATER CUT-OFF
- HIGH LIMITS

NOTICE Verify that the piping and controls ensure the boiler return water temperature does NOT drop below **140 °F, 60 °C**. Operating at lower return temperatures is likely to cause condensation in the primary heat exchanger, resulting in corrosion and possible failure of the heat exchanger.

COMMISSIONING THE BOILER

| | |
|---|--|
| <ul style="list-style-type: none"> <input type="checkbox"/> UNIT CYCLED MINIMUM OF 15 TIMES <input type="checkbox"/> CUSTOMER INSTRUCTED <input type="checkbox"/> ALL COVERS REPLACED <input type="checkbox"/> CUSTOMER GIVEN MANUAL <input type="checkbox"/> TARGET TEMPERATURE SET PER CUSTOMER <p>COMMISSIONED BY: _____ (SIGNATURE)</p> <p>DATE: _____</p> | <p>THE DELTA T BETWEEN THE HEATER INLET AND OUTLET IS CRITICAL TO PROPER FLOW. BEFORE YOU LEAVE THE JOBSITE, YOU MUST RECORD THE DELTA T. THIS READING SHOULD NOT EXCEED 35°F, 19.4°C, NOR BE LOWER THAN 20°F, 11.1°C.</p> <p style="text-align: center;">DELTA T = <input style="width: 100px; height: 20px;" type="text"/></p> |
|---|--|

ADDITIONAL NOTES AND COMMENTS

LIMITED WARRANTY

Boilers

The “Manufacturer” warrants to the original owner at the original installation site that the heat exchanger of the Industrial, Commercial, and other Non-Residential Use Boiler (the “Product”) will be free from defects in material or workmanship for ten (10) years from the date of installation. Additional twenty one (21) year thermal shock warranty on heat exchanger. If upon examination by the Manufacturer the Product is shown to have a defect in material or workmanship during the warranty period, the Manufacturer will repair or replace, at its option, that part of the Product which is shown to be defective. All other RBI supplied Boiler parts are warranted against defects in material and workmanship for one (1) year from date of installation or 18 months from date of shipment from RBI.

This limited warranty does not apply:

- (a) if the Product has been subjected to misuse or neglect, has been accidentally or intentionally damaged, has not been installed, maintained or operated in accordance with the furnished written instructions, or has been altered or modified in any way.

These include but not limited to:

- Excessive water hardness causing a lime build-up in the heat exchanger tubes is not a fault of the equipment and is not covered under the manufacturer’s warranty.
- Excessive pitting and erosion on the inside of the heat exchanger tubes caused by high water velocity through the tubes and is not covered by the manufacturer’s warranty. (See Installation Instructions for proper pump performance.)
- Chemical corrosion, no corrosive chemical (freon, dry cleaning chemicals, degreasing liquids, chlorine or any chemicals that produce hydrochloric acid) can be present in the boiler room as it rapidly destroys the heating equipment and voids the warranty.
- All copper fin boilers should not operate with a return water temperature less than **110°F, 43°C** atmospheric combustion, **125°F, 52°C** fan assist combustion. If a lower temperature is required, an external bypass should be installed to prevent condensation. The manufacturer’s warranty does not cover damage done by condensation.

- (b) to any expenses, including labor or material, incurred during removal or reinstallation of the Product or parts thereof.
- (c) to damage as a result of settlement, distortion, collapse, or cracking of any foundation area, beams or pipes surrounding the Product.
- (d) to any workmanship of any installer of the Product; or to Products installed outside the continental United States or Canada.

This limited warranty is conditional upon:

- (a) shipment, to the Manufacturer, of that part of the Product thought to be defective. Goods can only be returned with prior written approval from the Manufacturer. All returns must be freight prepaid.
- (b) determination in the reasonable opinion of the Manufacturer that there exists a defect in material or workmanship.

Repair or replacement of any part under this Limited Warranty shall not extend the duration of the warranty with respect to such repaired or replaced part beyond the stated warranty period.

THIS LIMITED WARRANTY IS IN LIEU OF ALL OTHER WARRANTIES, EITHER EXPRESS OR IMPLIED, AND ALL SUCH OTHER WARRANTIES, INCLUDING WITHOUT LIMITATION IMPLIED WARRANTIES OF MERCHANTABILITY OR FITNESS FOR A PARTICULAR PURPOSE, ARE HEREBY DISCLAIMED AND EXCLUDED FROM THIS LIMITED WARRANTY. IN NO EVENT SHALL THE MANUFACTURER BE LIABLE IN ANY WAY FOR ANY CONSEQUENTIAL, SPECIAL, OR INCIDENTAL DAMAGES OF ANY NATURE WHATSOEVER, OR FOR ANY AMOUNTS IN EXCESS OF THE SELLING PRICE OF THE PRODUCT OR ANY PARTS THEREOF FOUND TO BE DEFECTIVE. THIS LIMITED WARRANTY GIVES THE ORIGINAL OWNER OF THE PRODUCT SPECIFIC LEGAL RIGHTS. YOU MAY ALSO HAVE OTHER RIGHTS WHICH MAY VARY BY EACH JURISDICTION.